



**MANUFACTURED BY:**  
**Backyard Discovery**  
 3305 Airport Drive, Pittsburg, KS 66762  
 800-856-4445

Basepoint Business Centre: Rivermead Drive, Westlea, Swindon SN5 7EX Phone: 0800-118-2476  
 J.P. Coenstraat 7, The Bridge, The Hague, 2595 WP, Netherlands

# SKYFORT II

## Swing Set

### Model # 6113D



**WARNING**  
**Adult Assembly Required.**  
*Not suitable for children under 36 months due to small parts.*  
**FOR DOMESTIC USE ONLY. INTENDED FOR OUTDOOR USE.**



**Please visit [www.backyarddiscovery.com](http://www.backyarddiscovery.com)**

For the most up to date assembly manual, to register your set, or to order replacement parts  
*Para obtener instrucciones en español, visite [www.backyarddiscovery.com](http://www.backyarddiscovery.com)*



**EASY STEP-BY-STEP**  
**3D INTERACTIVE INSTRUCTIONS**

DOWNLOAD THE FREE APP



**INSTALLATION SERVICES AVAILABLE!**  
*See inside for details*



**GOCONFIGURE**  
*Putting it all together for you*

# INSTALLATION SERVICES AVAILABLE!\*

*Need a helping hand?*

Let our team of professionals handle the installation for you!

**GOCONFIGURE**  
**888-888-5424**

*\*Installation services are only available  
to U.S. customers.*

With Go Configure, we bring you 18 years of experience right to your doorstep. We service a wide array of indoor and outdoor recreation products that most consumers don't have the time or ability to deliver & install themselves.

**We do the heavy lifting, so you don't have to!**

- 18+ Years of Experience Servicing Big Box Retailers and Direct Consumers
- Highly Skilled, Specialized, Courteous, Professional Service Technicians
- Over 140,000 Installations Annually
- White Glove Service

- Satisfaction Guarantee
- Flexible Appointments, including weekends
- Coverage across the nation

**Visit [www.goconfigure.com](http://www.goconfigure.com) for more info!**

*\*Installation services are only available to U.S. customers.*



The store where you made your purchase does not stock parts for this item.

If you have assembly questions or you are missing or have damaged parts, please call

**1-800-856-4445**

you can also visit [www.backyarddiscovery.com](http://www.backyarddiscovery.com)  
or e-mail [customerservice@backyarddiscovery.com](mailto:customerservice@backyarddiscovery.com)

**Please have the following information ready when you make your call:**

- Model Number of the product located on the front of the assembly manual
  - Description of the part from the parts list
- 
- Read entire assembly manual, paying special attention to the important tips and safety information.
  - Ensure there are no missing pieces by first separating and identifying all parts.
  - Make sure to check packing material for small parts that may have fallen out during shipment.
  - Structures are not intended for public use. Any unintended use such as home child care, daycare center, faith center, government facility, home owner's associate, park or school will make the warranty of our product null & void.
  - This manual contains helpful information concerning assembly preparation, installation procedure and required maintenance.
  - Always keep safety in mind as your structure is being built.
  - Keep these instructions for future reference.



## THE MANUFACTURER RESERVES THE RIGHT TO MAKE SUBSTITUTIONS TO WARRANTY CLAIMS IF PARTS ARE UNAVAILABLE OR OBSOLETE

This Limited Warranty by Backyard Discovery applies to products manufactured under the Backyard Discovery brand or its other brands including but not limited to Adventure Playsets, and Leisure Time Products.

### Backyard Discovery Wood Play Structure

Backyard Discovery warrants this wooden play product to be free from defects in materials and workmanship for a period of two (2) years from the original date of purchase. All wood carries a five (5) year warranty against rot and decay from the original purchase date.

### Backyard Discovery Metal Play Structure

Backyard Discovery warrants this metal play product to be free from defects in materials and workmanship for a period of five (5) years from the original date of purchase.

### General Warranty Information

This warranty applies to the original owner and registrant and is non-transferable. Regular maintenance is required to ensure maximum life and performance of this product. Failure by the owner to maintain the product according to the maintenance requirements may void this warranty. Maintenance guidelines are provided in the Owner's Manual.

### This Limited Warranty does not cover:

- Natural occurring properties of wood such as twisting, warping, checking, peeling or any other natural occurring properties of wood that do not affect performance or integrity.
- Installation the warranty is null and void if installation is not in accordance with the Assembly Instructions.
- Labor for any inspection
- Labor for replacement of any defective item(s)
- Incidental or consequential damages
- Cosmetic defects, including rusting, color fading, minor cracks, corrosion, which do not affect performance or integrity of a part or the entire product.
- Vandalism, improper use, failure due to loading or use beyond the capacities stated in the applicable Assembly Manual.
- Acts of nature including but not limited to wind, storms, hail, floods, excessive water exposure.
- Improper installation including but not limited to installation on uneven, unlevel, or soft ground.

Backyard Discovery products have been designed for safety and quality. Any modifications made to the original product could damage the structural integrity of the unit leading to failure and possible injury. Modification voids any-and-all warranties and Backyard Discovery assumes no liability for the modified products or consequences resulting from failure of a modified product. Backyard Discovery disclaims all other representations and warranties of any kind, express or implied.

This product is warranted for RESIDENTIAL USE ONLY. Under no circumstance should a Backyard Discovery product be used in public settings (public settings include but are not limited to churches, day cares, parks, etc.). Such use may lead to product failure and potential injury. Any and all public use will void this warranty.

**USA and Canada:** To make a warranty or replacement part claim please visit backyarddiscovery.com or call Backyard Discovery customer service at 800-856-4445. Backyard Discovery will, at its sole discretion, replace any part within the stated warranty period that is defective in workmanship or materials. At Backyard Discovery's discretion, photographs of the defective part, physical return of the defective part to Backyard Discovery, or proof of purchase may be required for verification.

**Outside of the USA and Canada:** Contact place of purchase or distributor for warranty service.

*This Warranty gives you specific legal rights. You may have other rights as well which vary from state to state, province to province or country to country, where you bought the product. This warranty excludes all consequential damages however, some states do not allow the limitation or exclusion of consequential damages and therefore this limitation may not apply to you.*

### Please read entire booklet completely before beginning the assembly process

**Please retain these instructions and your receipt for future reference. Keep them in a safe place where you can refer to them as needed. In order to provide you with the most efficient service, it is required that you provide us with the part numbers when ordering parts.**

### For Your Records:

Please take time and fill out the information below. This information will be needed for warranty issues.

Where Purchased: \_\_\_\_\_  
 Date of Purchase: \_\_\_\_\_  
 Installation Date: \_\_\_\_\_  
 Installed by: \_\_\_\_\_  
 Tracking Number: \_\_\_\_\_

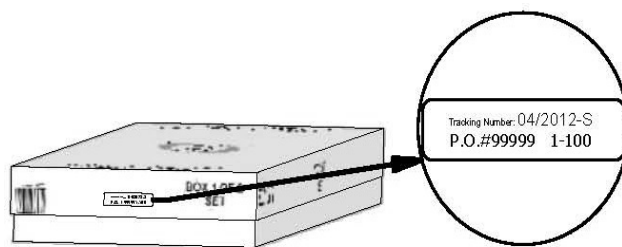

### Tracking Number Reference Label

Tracking ID number on the carton and on the bottom of the vertical ID plate are included for tracking purposes associated with warranty claims.



### NOTE:

#### Your Children's Safety Is Our #1 Concern!

Observe the following statements and warnings to reduce the likelihood of serious or fatal injury. Please review these safety rules regularly with your children.



### WARNING: BURN HAZARD

- Pay special attention to plastic and metal surfaces as they may be hot enough to cause burns.
- Always check the temperature of the product before letting your children play on it.
- Remember that the product may cause burns if left in direct sunlight.
- Always be aware of the sun and weather conditions, and do not assume that the equipment is safe because the air temperature is not very high.

- Children **MUST NOT** use this playcenter until unit has been completely assembled and inspected by an adult to ensure set has been properly installed and anchored.
- Equipment is recommended for use by children 3 to 10 years of age.
- This Playcenter is designed for a specific number of occupants whose combined weight should not exceed the designated weight on the elevated floor or the swing area. The total unit capacity is outlined in the Basic Setup Dimensions section of instruction manual. The maximum fall height and recommended play area is also available in the Basic Setup Dimensions section of the manual.
- On-site, continuous adult supervision is **REQUIRED. MOST SERIOUS INJURIES AND DEATHS ON PLAYGROUND EQUIPMENT HAVE OCCURRED WHILE CHILDREN WERE UNSUPERVISED!**
- **DO NOT** allow children to walk close to, in front of, behind, or between moving swings or other moving playground equipment.
- **DO NOT** let children stand on swings.
- Children should **NOT** twist the chains and ropes and should not loop them over the top support bar, this could reduce the strength of the chain or rope.
- **DO NOT** let children push empty seats. The seat could hit them and cause serious injury.
- Instruct and teach children to sit in the center of the swings with their full weight on the seats.
- **DO NOT** allow children to use the equipment in a manner other than intended.
- Instruct children **NOT** to get off equipment while it is in motion.
- Instruct children to **ALWAYS** go down slides feetfirst. Never slideheadfirst.
- Instruct children to **LOOK** before they slide to make sure no one is at the bottom.
- **DO NOT** allow children to go down slide head first or run up slide.
- **DRESS CHILDREN APPROPRIATELY.** (Examples would include wearing well-fitting shoes and the avoidance of ponchos, scarfs, and other loose-fitting clothing that is potentially hazardous while using equipment). Children must wear shoes when using the play set. Do not allow children to wear open toe or heel footwear like sandals, flip-flops or clogs.
- **DO NOT** allow children to climb when the equipment is wet.
- Children should **NEVER** jump from a fort deck. They should always use the ladder, ramp or slide.
- Children should **NEVER** be allowed to crawl or walk across the top of monkey bars.
- **DO NOT** allow children to crawl on top of a fort roof.
- Verify that any suspended climbing ropes, chain, or cable are secured at both ends and that they cannot be looped back on themselves as to create an entanglement hazard.
- **DO NOT** let children attach items to the playground equipment that are not specifically designed for use with the equipment. Items such as, but not limited to, jump ropes, clothesline, pet leashes, cables and chain can cause a strangulation hazard.
- Children should **NEVER** wrap their legs around swing chain.
- **DO NOT** allow children to slide down the swing chain.
- Instruct children to remove their bike or other sports helmet before playing on playground equipment.
- **NEVER** add extra length to chain or rope. The chains or ropes provided are the maximum length designed for the swinging element(s).
- On sunny and/or hot days, check the slide and other plastic rides to assure that they are not hot to the touch to cause burns. Cool hot slide and rides with water and wipe dry prior to using.

### Modifications

- Modifications made by the consumer to the original activity toy shall be carried out according to the instructions of the manufacturer. In particular, instructions shall be provided with kit/accessory about the installation of rope/nets concerning the minimum diameter, the need for fixation at both ends, overall length, and positioning in relation to other structures.



### Positioning Your Playcenter

- The playcenter is designed to be installed on a level surface by an adult with an adult helper. Place in a flat area of your yard to minimize ground preparation.
- Choose a level location for the equipment. This can reduce the likelihood of the play set tipping over and loose-fill surfacing material washing away during heavy rains.
- Place the equipment not less than 6'-7" (2.0 m) from any structure or obstruction such as a fence, garage, house, overhanging branches, laundry lines, or electrical wires.
- Provide enough room so that the children can use the equipment safely. For example, for structures with multiple play activities, a slide should not exit in front of a swing.
- It is a good idea to place your playcenter in an area that is convenient for adults to watch children at play.
- Create a site free of obstacles that could cause injuries – such as low overhanging tree branches, overhead wires, tree stumps and/or roots, large rocks, bricks and concrete. Additional suggestions in the Suggested Playground Surfacing Section.
- Do not build your playset on top of surfacing material.
- Locate bare metal platforms and slides out of direct sunlight to reduce the likelihood of serious burns. A slide that faces north will receive the least direct sunlight.
- Separate active and quiet activities from each other. For example, locate sandboxes away from swings or use a guardrail or barrier to separate the sandbox from the movement of the swings.

### Suggested Playground Surfacing

- Do not install home playground equipment over concrete, asphalt, packed earth, grass, carpet, or any other hard surface. A fall onto a hard surface can result in serious injury to the equipment user.
- Do not install loose fill surfacing over hard surfaces such as concrete or asphalt.
- Shredded bark mulch, wood chips, fine sand and fine gravel, are added as shock absorbing materials after assembly. If used properly these materials can absorb some of the impact of a child's fall.
- All surface material should extend a minimum of 6'-7" (2.0 m) feet in all directions around the play area.
- Do not apply playground surfacing until after the unit is completely constructed. Playset should not be built on top of surfacing.
- Use containment, such as digging out around the perimeter and/or lining the perimeter with landscape edging.
- Installations of rubber tiles or poured-in-place surfaces (other than loose-fill materials) generally require a professional and are not "do-it-yourself" projects.
- Shall use Playground Surfacing Materials (other than loose-fill material) which comply with the safety standard ASTM F1292 Standard Specification of Impact Attenuation of Surfacing Materials within the Use Zone of Playground Equipment.
- Anchors shall be placed as instructed to reduce tipping hazards.

The following chart explains the fall height in feet from which a life threatening head injury would not be expected

### Critical Heights in feet (m) of Tested Materials

Material	Uncompressed Depth			Compressed Depth to 9" (228mm)
	6" (152mm)	9" (228mm)	12" (304mm)	
Wood Chips	7' (2.13m)	10-12' (3.0-3.6m)	11' (3.35m)	10' (3.05m)
Double-Shredded Bark Mulch	6' (1.83m)	10-12' (3.0-3.6m)	11' (3.35m)	7' (2.13m)
Engineered Wood Fibers	6' (1.83m)	7' (2.13m)	>12' (3.66m)	6' (1.83m)
Fine Sand	5' (1.52m)	5' (1.52m)	9' (2.74m)	5' (1.52m)
Coarse Sand	5' (1.52m)	5' (1.52m)	6' (1.83m)	4' (1.22m)
Fine Gravel	5' (1.52m)	7' (2.13m)	10' (3.05m)	6' (1.83m)
Medium Gravel	5' (1.52m)	5' (1.52m)	6' (1.83m)	5' (1.52m)
Shredded Tires*	10-12' (3.0-3.6m)	N/A	N/A	N/A

\*This data is from tests conducted by independent testing laboratories on a 6-inch depth of uncompressed shredded tire samples produced by four manufacturers. The tests reported critical heights, which varied from 10 feet to greater than 12 feet. It is recommended that persons seeking to install shredded tires as a protective surface request test data from the supplier showing the critical height of the material when it was tested in accordance with ASTM F1292.



### APPENDIX A

**The following information is from the United States Consumer Product Safety Commission's Information Sheet for playground surfacing material; also see the following website for additional information: [www.cpsc.gov](http://www.cpsc.gov)**

#### X3. SECTION 4 OF THE CONSUMER PRODUCT SAFETY COMMISSION'S OUTDOOR HOME PLAYGROUND SAFETY HANDBOOK<sup>9</sup>

X3.1 Select Protective Surfacing—One of the most important things you can do to reduce the likelihood of serious head injuries is to install shock-absorbing protective surfacing under and around your play equipment. The protective surfacing should be applied to a depth that is suitable for the equipment height in accordance with ASTM Specification F 1292. There are different types of surfacing to choose from; whichever product you select, follow these guidelines:

##### X3.1.1 Loose-Fill Materials:

X3.1.1.1 Maintain a minimum depth of 9 inches of loose-fill materials such as wood mulch/chips, engineered wood fiber (EWF), or shredded/recycled rubber mulch for equipment up to 8 feet high; and 9 inches of sand or pea gravel for equipment up to 5 feet high. NOTE: An initial fill level of 12 inches will compress to about a 9-inch depth of surfacing overtime. The surfacing will also compact, displace, and settle, and should be periodically refilled to maintain at least a 9-inch depth.

X3.1.2 Use a minimum of 6 inches of protective surfacing for play equipment less than 4 feet in height. If maintained properly, this should be adequate. (At depths less than 6 inches, the protective material is too easily displaced or compacted.)

NOTE: Do not install home playground equipment over concrete, asphalt, or any other hard surface. A fall onto a hard surface can result in serious injury to the equipment user. Grass and dirt are not considered protective surfacing because wear and environmental factors can reduce their shock absorbing effectiveness. Carpeting and thin mats are generally not adequate protective surfacing. Ground level equipment such as a sandbox, activity wall, playhouse or other equipment that has no elevated play surface – does not need any protective surfacing.

X3.1.3 Use containment, such as digging out around the perimeter and/or lining the perimeter with landscape edging. Don't forget to account for water drainage.

X3.1.3.1 Check and maintain the depth of the loose-fill surfacing material. To maintain the right amount of loose-fill materials, mark the correct level on play equipment support posts. That way you can easily see when to replenish and/or redistribute the surfacing.

X3.1.3.2 Do not install loose-fill surfacing over hard surfaces such as concrete or asphalt.

X3.1.4 Poured-In-Place Surfaces or Pre-Manufactured Rubber Tiles — You may be interested in using surfacing other than loose-fill materials – like rubber tiles or poured-in-place surfaces.

X3.1.4.1 Installations of these surfaces generally require a professional and are not “do-it-yourself” projects.

X3.1.4.2 Review surface specification before purchasing this type of surfacing. Ask the installer/manufacture for a report showing that the product has been tested to the following safety standard: ASTM F 1292 Standard Specification for Impact Attenuation of Surfacing Materials within the Use Zone of Playground Equipment. This report should show the specific height for which the surface is intended to protect against serious head injury. This height should be equal to or greater than the fall height – vertical distance between a designated play surface (elevated surface for standing, sitting, or climbing) and the protective surfacing below – of your play equipment

X3.1.4.3 Check the protective surfacing frequently for wear.

X3.1.5 Placement — Proper placement and maintenance of protective surfacing is essential. Be sure to:

X3.1.5.1 Extend surfacing at least 6 feet from the equipment in all directions.

X3.1.5.2 For to-fro swings, extend protective surfacing in front of and behind the swing to a distance equal to twice the height of the top bar from which the swing is suspended.

<sup>9</sup>This information has been extracted from the CPSC publications “Playground Surfacing — Technical Information Guide” and “Handbook for Public Playground Safety.” Copies of these reports can be obtained by sending a postcard to the: Office of Public Affairs, U.S. Consumer Product Safety Commission, Washington, D.C., 20207 or call the toll-free hotline: 1-800-638-2772.

The American Society for Testing and Materials takes no position respecting the validity of any parent right asserted in connection with any item mentioned in this standard. Users of this standard are expressly advised that determination of the validity of any such parent rights, and the risk of infringement of such rights, are entirely their own responsibility.

The standard is subject to revision at any time by the responsible technical committee and must be reviewed every five years and if not revised, either approved or withdrawn. Your comments are invited either for revision of this standard or for additional standards and should be addressed to ASTM Headquarters. Your comments will receive careful consideration at a meeting of the responsible technical committee, which you may attend. If you feel that your comments have not received a fair hearing you should make your views known to the ASTM Committee on Standards. 100 Barr Harbor Drive, West Conshohocken, PA 19428.



**IT IS IMPORTANT TO CHECK AND TIGHTEN ALL HARDWARE AT THE BEGINNING AND DURING THE SEASON AS THEY MAY LOOSEN DUE TO WOOD EXPANSION AND CONTRACTION.**

### At the beginning of each play season

- Tighten all hardware.
- Lubricate all metallic moving parts per manufacturer's instructions.
- Check all protective coverings on bolts, pipes, edges, and corners. Replace if they are loose, cracked, or missing.
- Check all moving parts including swing seats, ropes, cables, and chains for wear, rust, or other deterioration. Replace as needed.
- Check metal parts for rust. If found, sand and repaint using a non lead-based paint meeting the requirements of 16 CFR 1303.
- Check all wood members for deterioration and splinters. Sand down splinters and replace deteriorating wood members.
- Reinstall any plastic parts, such as swing seats or any other items that were removed for the cold season.
- Rake and check depth of loose fill protective surfacing materials to prevent compaction and to maintain appropriate depth. Replace as necessary.

### Twice a month during play season

- Tighten all hardware.
- Check all protective coverings on bolts, pipes, edges, & corners. Replace if they are loose, cracked, or missing.
- Rake and check depth of loose fill protective surfacing materials to prevent compaction and to maintain appropriate depth. Replace as necessary.

### Once a month during play season.

- Lubricate all metallic moving parts per manufacturer's instructions.
- Check all moving parts including swing seats, ropes, cables, and chains for wear, rust, or other deterioration. Replace as needed.

### At the end of each season or when the temperature drops below 32° F

- Remove plastic swing seats and other items as specified by the manufacturer and take indoors or do not use.
- Rake and check depth of loose fill protective surfacing materials to prevent compaction and to maintain appropriate depth. Replace as necessary.

### Additional Maintenance

- Check the swing beam and hardware every two weeks due to wood expansion and contraction. It is particularly important that this procedure be followed at the beginning of each season.
- Inspect wood parts monthly. The grain of the wood sometimes will lift in the dry season causing splinters to appear. Light sand may be necessary to maintain a safe playing environment. Treat your playset with stain regularly, to help prevent severe checking/splitting and other weather damage.
- A waterborne transparent stain has been applied to your playset. This is done for color only. Once or twice a year, depending on your climate conditions, you must apply some type of protection (sealant) to the wood of your unit. Prior to the application of sealant, lightly sand any "rough" spots on your playset. Please note this is a requirement of your warranty.
- Assembling and maintaining the playset on a level location is very important. As your children play, your playset will slowly dig its way into the soil, and it is very important that it settles evenly. Make sure the playset is level and true one each year or at the beginning of each play season.

### Disposal Instructions

When the Playcenter use is no longer desired, it should be disassembled and disposed of in such a way that no unreasonable hazards will exist at the time the unit is discarded.



### Third Party Assembly

- Customer may, in their sole discretion, elect to use a third party person or service to assemble this product. Backyard Discovery assumes no responsibility or liability for any charge incurred by the Customer for any assembly services. Please see our warranty for more information about damaged and missing part replacement coverage. Backyard Discovery will not reimburse Customer for the price of parts purchased.
- Modifications made by the consumer to the original activity toy shall be carried out according to the instructions of the manufacturer. In particular, instructions shall be provided with kit/accessory about the installation of rope/nets concerning the minimum diameter, the need for fixation ends, overall length, and positioning in relation to other at both structures.

**OWNERS SHALL BE RESPONSIBLE FOR MAINTAINING THE LEGIBILITY OF THE WARNING LABELS**





***Your Backyard Discovery structure is designed and constructed of quality materials. As with all outdoor products it will weather and wear. To maximize the enjoyment, safety and life of your structure it is important that you properly maintain it.***

---

### About Our Wood

Backyard Discovery takes great care in selecting the best quality lumber available, wood is still a product of nature and susceptible to weathering which can change the appearance of your set.

#### What causes weathering? Does it affect the strength of my product?

One of the main reasons for weathering is the effects of water (moisture); the moisture content of the wood at the surface is different than the interior of the wood. As the climate changes, moisture moves in or out of the wood, causing tension which can result in checking and or warping. You can expect the following due to weathering. These changes will not affect the strength of the product:

**1. Checking** is surface cracks in the wood along the grain. A post (4" x 4") will experience more checking than a board (1" x 4") because the surface and interior moisture content will vary more widely than in thinner wood.

**2. Warping** results from any distortion (twisting, cupping) from the original plane of the board and often happens from rapid wetting and drying of the wood.

**3. Fading** happens as a natural change in the wood color as it is exposed to sun-light and will turn grey over time.

#### How can I reduce the amount of weathering to wood product?

**1.** Your wood product is coated with a water-based stain. Sunlight will break down the coating, so we recommend applying a water repellent or stain on a yearly basis (see your local stain and paint supplier for a recommended product). You must apply some type of protection (sealant) to the wood of your product. **Please note this is a requirement of your warranty.** Most weathering is just the normal result of nature and will not affect safety. However if you are concerned that a part has experienced a severe weathering problem please call our customer service department for further assistance.

**2.** Inspect wood parts monthly. The grain of the wood sometimes will lift in the dry season causing splinters to appear. Light sanding may be necessary to maintain a safe environment. Treating your Product with protection (sealant) after sanding will help prevent severe checking/splitting and other weather damage.



### Protrusion Hazard

#### Incorrect

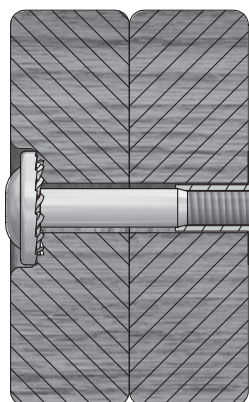

If you see exposed threads and your bolt protrudes beyond the T-Nut you may have over tightened the bolt or used incorrect hardware. If you've overtightened, remove the bolt and add washers to eliminate the protrusion.

#### Correct

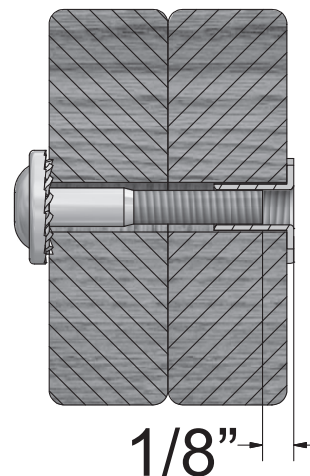

## Proper Hardware Assembly

### Bolt and T-Nut Assembly

Tap T-nut into the provided hole. Insert your bolt through the lock washer and insert into the provided hole opposite from the T-Nut. Turn clockwise to thread into T-nut. Do not completely tighten until instructed.

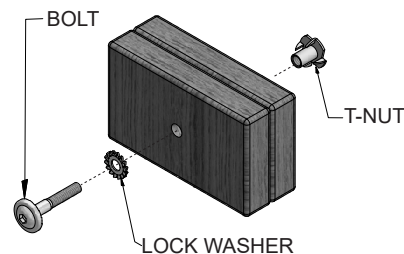

### Bolt and Barrel Nut Assembly

Insert barrel nut through the lock washer and press the pair through the provided hole. Insert your bolt through the second lock washer and insert the pair into the provided hole opposite from the barrel nut. Turn clockwise to thread into the barrel nut. Do not completely tighten until instructed.

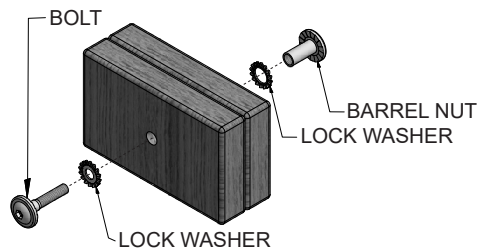

### Lag Assembly

Normally there will be a pre-drilled pilot hole on assemblies that require a Lag Screw. If there is no pilot hole, line up the two boards as they are to be attached and use the factory drilled hole as a guide to drill another pilot hole into the adjoining board. This will keep the wood from splitting. Only a lock washer is required for steps with Lag Screws.

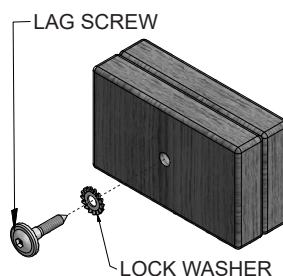



### ASSEMBLY TIP:

Keep an eye out for these boxes which will contain helpful pictures and information making the assembly process as quick and painless as possible.

## Sorting Wood

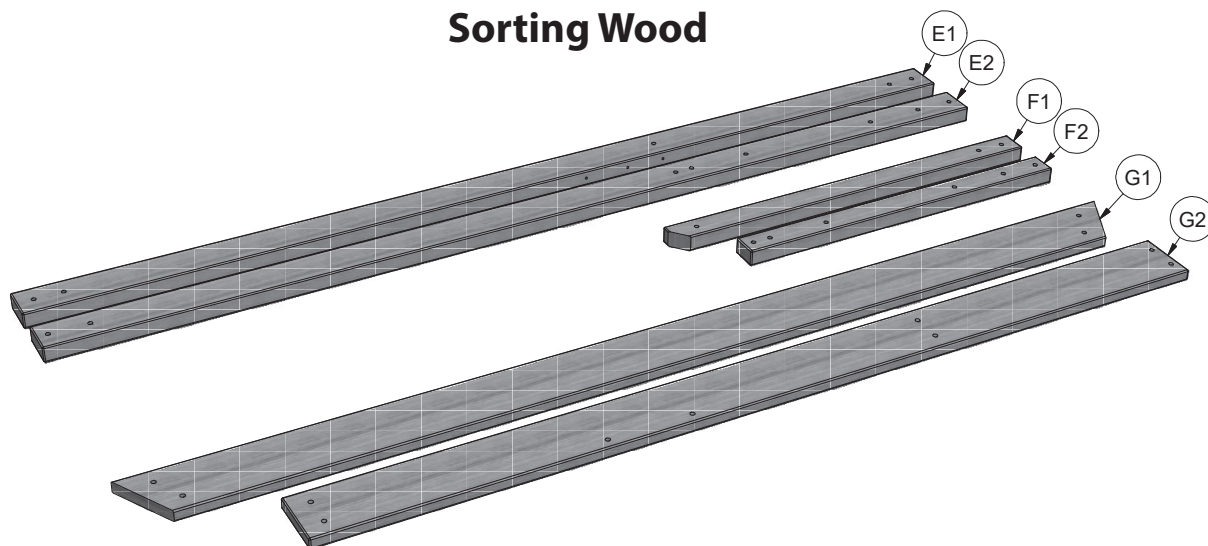

When removing the wood from the boxes we recommend arranging them by part number before you begin assembly. This will allow for faster assembly and easily identify any parts that may be missing or damaged.

## Sorting Hardware

**NUT BARREL**  
H100545



**SCREW**  
H100695

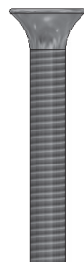

**T-NUT**  
H100699

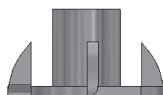

**WASHER FLAT**  
H100706

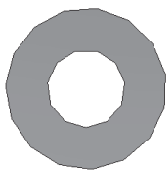

**BOLT HEX**  
H100716

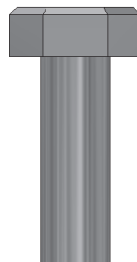

**BOLT**  
H100718



**SCREW PWH**  
H100742



To help with assembly we recommend sorting your hardware bags with the seven digit alpha-numeric number printed on the bags or by hardware type (i.e. bolts, nuts, etc.). Organizing your hardware will make assembly easier.

## Hardware Identification

Hardware bags are printed with a seven digit alpha-numeric part number. During assembly you only need to reference the last three digits of the part number as noted in each step. This will make finding the correct hardware easier.

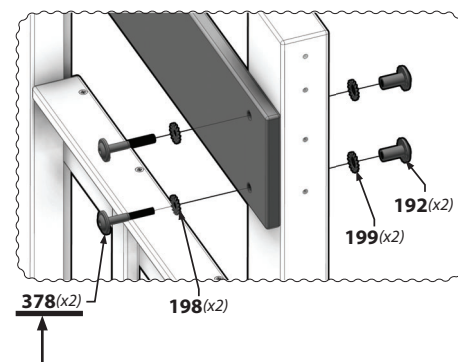
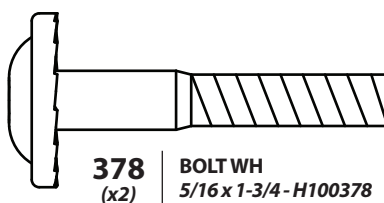

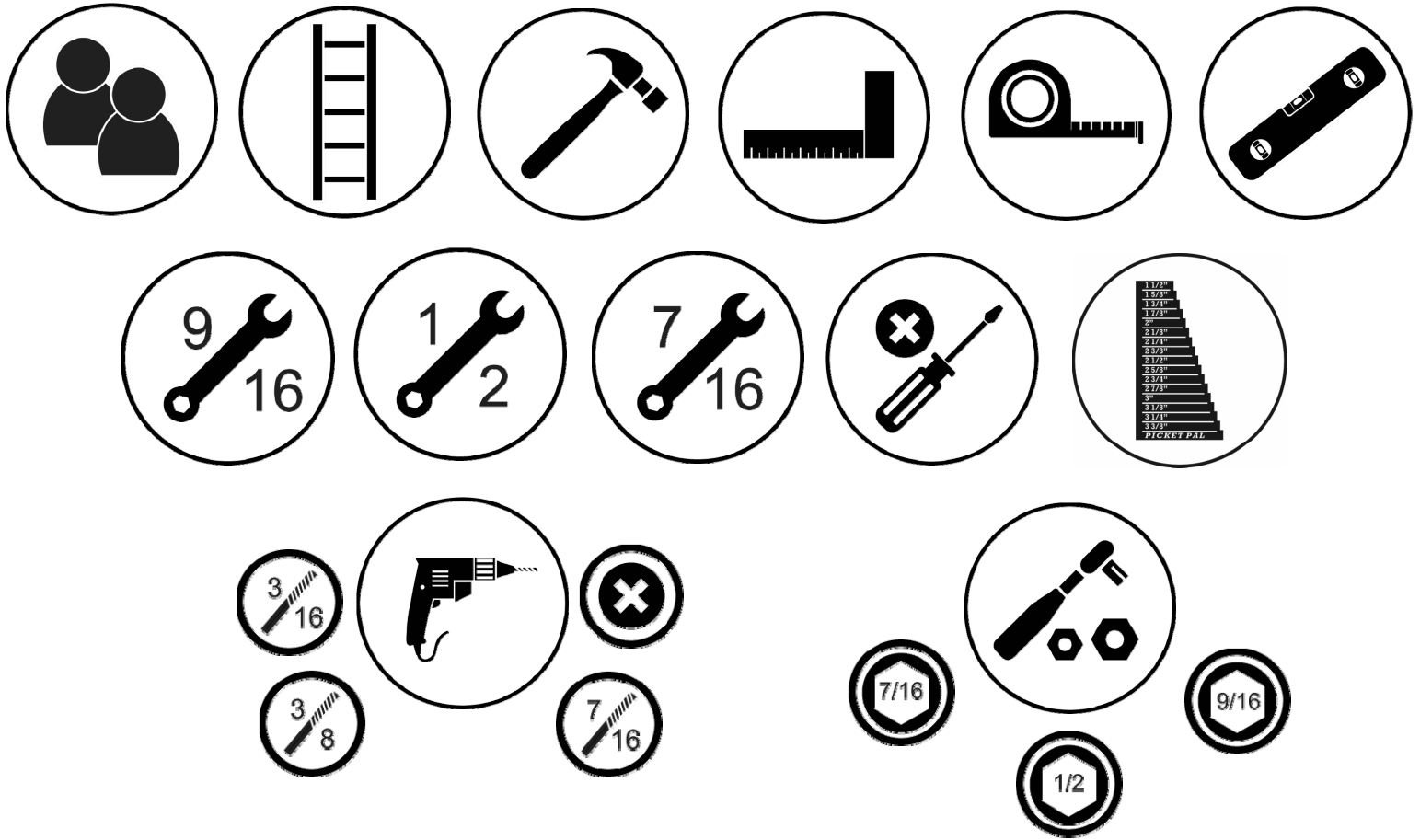
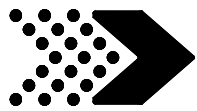

## Icons and their uses you will see throughout this manual



You will need to make sure that your assembly is square before tightening your bolts.



When you see this icon you will need a socket wrench. The icons below show the size of attachments needed for assembly 1/2.



For proper assembly you will need to ensure that your structure is level before proceeding to the next step.

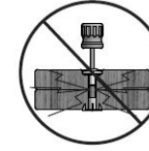

This icon warns you to not over tighten your bolts. This is to prevent structural damage and also splintering your wood.



Some steps in the assembly process will require an extra set of hands. Make sure you have a helper available.



A ladder will be needed for assembly. Do NOT stand on the set when it is incomplete, unstable, and not anchored. Failure to do so may result in injury.



This icon shows the size of an open ended wrench. Using the wrench as the fraction bar.



This icon will show you what drill attachments are needed. For this example you will need a Phillips head attachment and 3/8 drill bit.





Place the set on level ground, not less than 6'-7" [2 m] from any structure or obstruction such as a fence, garage, house, overhanging branches, laundry lines, or electrical wires.

- While assembling unit, take time before and after each phase to make sure fort is level. If fort is not level, assembly will be difficult and improper assembly may result. Extra care must be taken to insure the fort is square.
- The safe play area refers to a zone extending 6'-7" (2 m) beyond the play product on all sides, including the space above the play product.

## SAFE PLAY AREA DIAGRAM

### Ground Dimension

21.93 ft [6.7 m] x 16.76 ft [5.1 m]

### Safe Play Area

35.05 ft [10.7 m] x 29.88 ft [9.1 m]

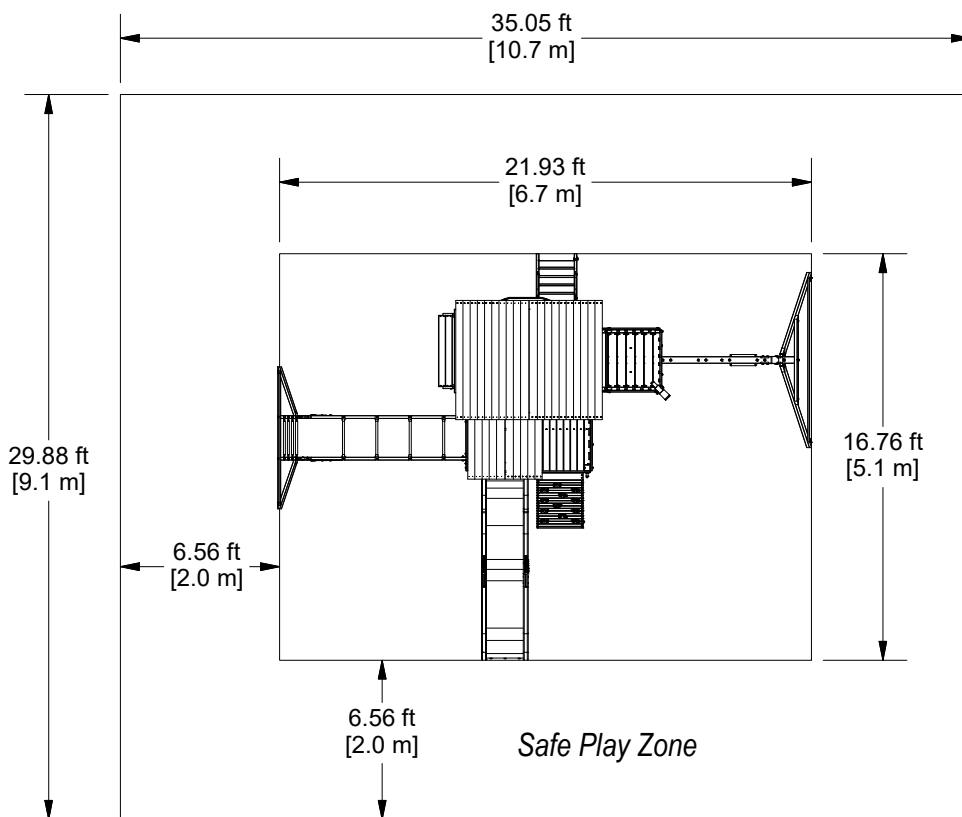

**SAFE PLAY HEIGHT: 18.37 ft [5.6 m]**  
**MAXIMUM FALL HEIGHT: 7.46 ft [2.3 m]**

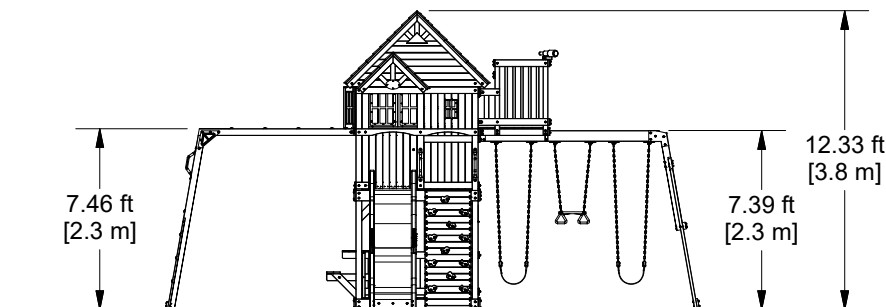

### General Information:

Your set has been designed and engineered for children only and for residential use only.  
 A maximum of 150 lbs. per child is recommended for play activities designed for individual use.  
 A maximum of 120 lbs. per child is recommended for play activities designed for multiple child use.  
 A maximum of 9 children is recommended for this swing set.



Wood Components (Not to Scale)



**A1 | SWING BEAM - W4L15890**  
(1) | 3 3/8"x5 1/4"x89 1/2" (86x134x2274)



**B1 | TOWER LEG - W2A03355**  
(1) | 3"x3"x89 1/2" (76x76x2274)



**B2 | TOWER LEG - W4L04561**  
(1) | 3"x3"x89 1/2" (76x76x2274)

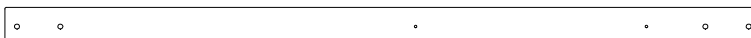

**B3 | TOWER LEG - W4L04564**  
(1) | 3"x3"x59" (76x76x1500)



**B4 | TOWER LEG - W4L04568**  
(1) | 3"x3"x59" (76x76x1500)

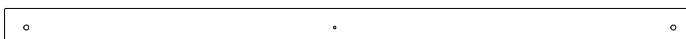

**B5 | BACK LEFT CLUB HOUSE CORNER - W4L04612**  
(1) | 3"x3"x53 7/8" (76x76x1370)

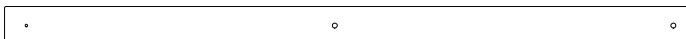

**B6 | FRONT LEFT CLUB HOUSE CORNER - W4L04615**  
(1) | 3"x3"x53 7/8" (76x76x1370)



**B7 | FRONT RIGHT FORT CORNER - W4L15897**  
(1) | 3"x3"x53 7/8" (76x76x1370)

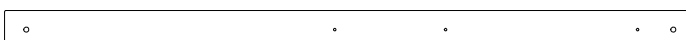

**B8 | BACK RIGHT FORT CORNER - W4L15898**  
(1) | 3"x3"x53 7/8" (76x76x1370)



**E1 | TOWER LEG - W4L04563**  
(1) | 1 3/8"x3 3/8"x59" (36x86x1500)



**E2 | TOWER LEG - W4L04567**  
(1) | 1 3/8"x3 3/8"x59" (36x86x1500)

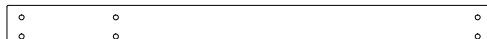

**E03 | CROWS NEST FLOOR RAIL - W4L15901**  
(2) | 1 3/8"x3 3/8"x38" (36x86x964)

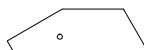

**E8 | CROWS NEST DECK BRACE - W4L15902**  
(2) | 1 7/16"x3 3/8"x10 7/8" (36x86x276)



**E6 | DECK BRACE - W4L15942**  
(8) | 1 7/16"x3 3/8"x20" (36x86x508)

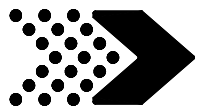

Wood Components (Not to Scale)

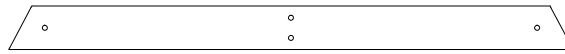

**E50 | END SUPPORT - W4L15893**  
(1) | 1 3/8"x3 3/8"x44 1/8" (36x86x1120)



**E7 | ANGLE BRACE - W4L15892**  
(2) | 1 3/8"x3 3/8"x87 1/8" (36x86x2212)



**E4 | MONKEY BAR RAIL - W4L15936**  
(2) | 1 3/8"x3 3/8"x77 1/8" (36x86x1959)

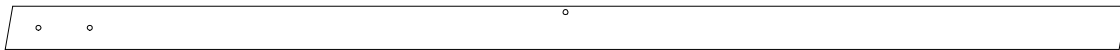

**E5 | MONKEY BAR UPRIGHT - W4L15937**  
(2) | 1 3/8"x3 3/8"x87 5/8" (36x86x2226)



**E72 | ROCKWALL RAIL - W4L15923**  
(2) | 1 3/8"x3 3/8"x64 5/8" (36x86x1640)



**E77 | LEFT UPRIGHT - W4L15932**  
(1) | 1 3/8"x3 3/8"x64 3/8" (36x86x1634)



**E78 | RIGHT UPRIGHT - W4L15933**  
(1) | 1 3/8"x3 3/8"x64 3/8" (36x86x1634)



**F02 | CROWS NEST WALL SUPPORT - W4L15908**  
(2) | 1 3/8"x2 3/8"x37 1/2" (36x60x952)



**F03 | CROWS NEST WALL SUPPORT - W4L15909**  
(2) | 1 3/8"x2 3/8"x37 1/2" (36x60x952)

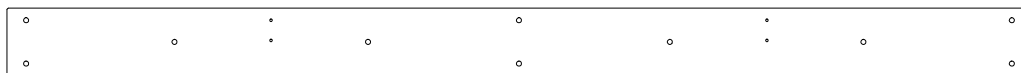

**G1 | TOP FLOOR RAIL - W4L04566**  
(1) | 1"x5 1/4"x80" (24x134x2032)

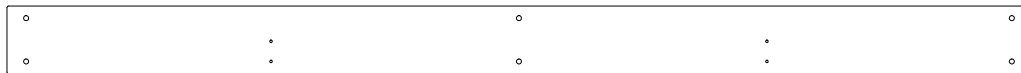

**G2 | TOP FLOOR RAIL - W4L04569**  
(1) | 1"x5 1/4"x80" (24x134x2032)



**G3 | FLOOR RAIL - W4L04571**  
(1) | 1"x5 1/4"x60 1/2" (24x134x1537)



**G4 | FLOOR RAIL - W4L04675**  
(1) | 1"x5 1/4"x60 1/2" (24x134x1537)

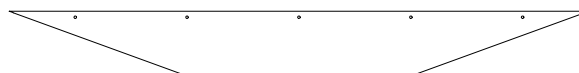

**G5 | BAY WINDOW HEADER - W4L04659**  
(4) | 1"x5 1/4"x45 1/4" (24x134x1150)

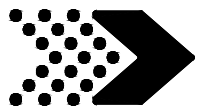

Wood Components (Not to Scale)

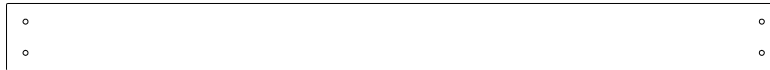

**G6 | FLOOR RAIL - W4L11777**  
(1) | 1"x5 1/4"x60 1/2" (24x134x1537)

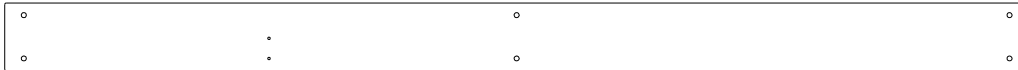

**G7 | BOTTOM FLOOR RAIL - W4L11775**  
(2) | 1"x5 1/4"x80" (24x134x2032)

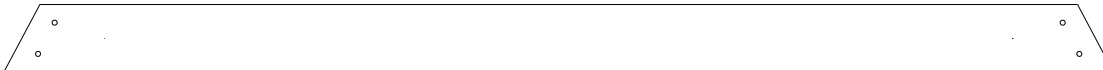

**G08 | GROUND BOARD - W4L15894**  
(1) | 1"x5 1/4"x86 3/4" (24x134x2202)



**H1 | WALL RAIL - W4L04620**  
(1) | 1"x3 3/8"x80" (24x86x2032)



**H2 | WALL RAIL - W4L15900**  
(1) | 1"x3 3/8"x80" (24x86x2032)



**H3 | PICNIC TABLE RAIL - W4L04578**  
(1) | 1"x3 3/8"x67 1/4" (24x86x1708)

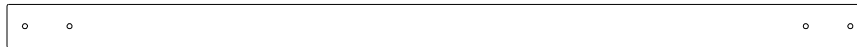

**H4 | ROOF SUPPORT RAIL - W4L04623**  
(2) | 1"x3 3/8"x67 1/4" (24x86x1709)

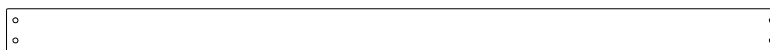

**H5 | FLOOR RAIL - W4L04608**  
(1) | 1"x3 3/8"x60 1/2" (24x86x1537)

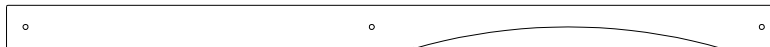

**H6 | BACK CLUB HOUSE RAIL - W4L04621**  
(1) | 1"x3 3/8"x60 1/2" (24x86x1537)

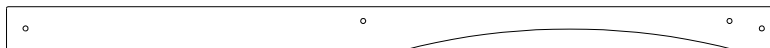

**H7 | FRONT CLUB HOUSE WALL RAIL - W4L04625**  
(1) | 1"x3 3/8"x60 1/2" (24x86x1537)

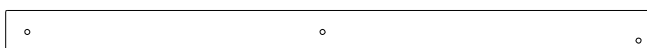

**H8 | FORT UPRIGHT - W4L15899**  
(1) | 1"x3 3/8"x50 1/2" (24x86x1284)

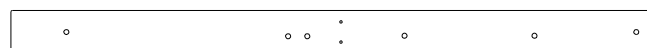

**H9 | FORT WALL BOARD - W4L15916**  
(2) | 1"x3 3/8"x50 1/2" (24x86x1284)

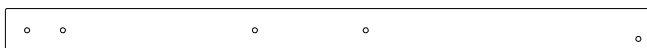

**H10 | PORCH LEG - W4L04683**  
(1) | 1"x3 3/8"x50 1/2" (24x86x1282)

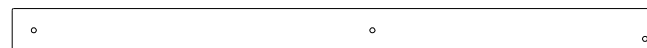

**H11 | PORCH LEG - W4L04610**  
(1) | 1"x3 3/8"x50 1/2" (24x86x1282)





Wood Components (Not to Scale)



**H12** | ROOF RAFTER - W4L04640  
(4) | 1"x3 3/8"x50 3/8" (24x86x1278)



**H13** | CLUB HOUSE WALL RAIL - W4L04624  
(1) | 1"x3 3/8"x50 1/4" (24x86x1277)

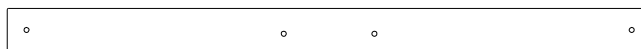

**H14** | SWING BEAM MOUNT - W4L15895  
(1) | 1"x3 3/8"x50 1/4" (24x86x1277)



**H15** | PICNIC TABLE SEAT - W4L04600  
(4) | 1"x3 3/8"x35 3/8" (24x86x897)

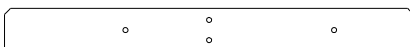

**H16** | PICNIC TABLE SEAT RAIL - W4L04597  
(1) | 1"x3 3/8"x32" (24x86x812)

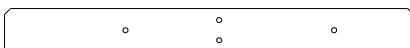

**H17** | PICNIC TABLE SEAT RAIL - W4L04599  
(1) | 1"x3 3/8"x32" (24x86x812)

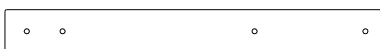

**H18** | CLUB HOUSE WALL RAIL - W4L04616  
(1) | 1"x3 3/8"x29 7/8" (24x86x758)



**H19** | CROWS NEST FLOOR RAIL - W4L15903  
(1) | 1"x3 3/8"x27" (24x86x686)



**H20** | PORCH ROOF RAFTER - W4L04655  
(4) | 1"x3 3/8"x24 1/2" (24x86x622)



**H21** | CROWS NEST FLOOR SUPPORT - W4L15904  
(1) | 1"x3 3/8"x24 1/8" (24x86x614)



**H22** | MONKEY BAR BRACE - W4L15934  
(2) | 1"x3 3/8"x53 1/4" (24x86x1352)

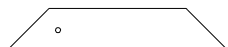

**H23** | PICNIC TABLE BRACE - W4L04598  
(2) | 1"x3 3/8"x17 1/2" (24x86x444)

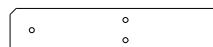

**H24** | PICNIC TABLE TOP SUPPORT - W4L04601  
(1) | 1"x3 3/8"x16 1/2" (24x86x418)



**H25** | TOP FLOOR SUPPORT - W4L04606  
(2) | 1"x3 3/8"x3" (24x86x76)



**H26** | FLOOR JOIST - W4L04573  
(3) | 1"x3 3/8"x60 1/2" (24x86x1537)

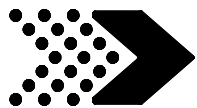

Wood Components (Not to Scale)



**H27** | PICNIC TABLE SUPPORT - W4L04574  
(1) | 1"x3 3/8"x28 5/8" (24x86x728)

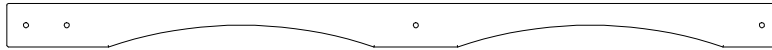

**H28** | FRONT WALL RAIL - W4L11774  
(1) | 1"x3 3/8"x60 1/2" (24x86x1537)



**H29** | CROWS NEST WALL RAIL - W4L15910  
(2) | 1"x3 3/8"x30 5/8" (24x86x778)



**H30** | CROWS NEST WALL RAIL - W4L11782  
(2) | 1"x3 3/8"x29 7/8" (24x86x758)



**H31** | CROWS NEST WALL RAIL - W4L15907  
(2) | 1"x3 3/8"x38 7/8" (24x86x988)



**H32** | MONKEY BAR GROUND BOARD - W4L15935  
(1) | 1"x3 3/8"x70 3/8" (24x86x1786)



**H76** | LADDER RUNG - W4L15931  
(5) | 1"x3 3/8"x18 1/8" (24x86x460)



**H77** | ATTACHMENT BOARD - W4L15929  
(1) | 1"x3 3/8"x20 1/8" (24x86x512)



**K2** | FLOOR RAIL - W4L04570  
(1) | 5/8"x5 1/4"x60 1/2" (16x134x1537)

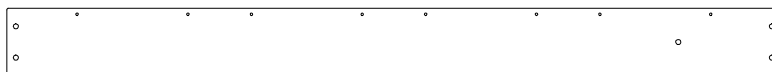

**K3** | FLOOR RAIL - W4L04572  
(1) | 5/8"x5 1/4"x60 1/2" (16x134x1537)

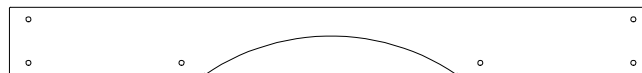

**K5** | CLUB HOUSE WALL RAIL - W4L04626  
(1) | 5/8"x5 1/4"x50 1/4" (16x134x1277)

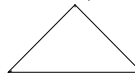

**K6** | TRIANGLE SUNBURST - W4L04827  
(2) | 5/8"x5 1/4"x10 3/8" (16x134x265)



**L01** | CROWS NEST FLOOR BOARD - W4L15905  
(7) | 5/8"x4 3/8"x27" (16x112x686)



**L03** | CROWS NEST FLOOR BOARD - W4L15906  
(2) | 5/8"x4 3/8"x27" (16x112x686)



**L2** | SAND BOX SEAT - W4L11776  
(2) | 5/8"x4 3/8"x24" (16x112x610)



Wood Components (Not to Scale)

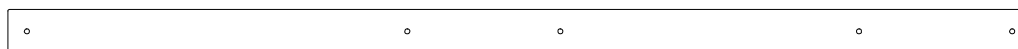

**M1 | TOP WALL RAIL - W4L04619**  
(1) | 5/8"x3 3/8"x80" (16x86x2032)

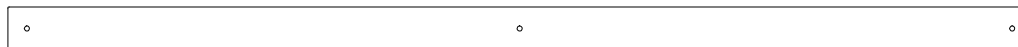

**M2 | BOTTOM WALL RAIL - W4L04596**  
(2) | 5/8"x3 3/8"x80" (16x86x2032)



**M3 | BOTTOM WALL RAIL - W4L04579**  
(1) | 5/8"x3 3/8"x60 1/2" (16x86x1537)



**M4 | CROWS NEST WALL RAIL - W4L11773**  
(2) | 5/8"x3 3/8"x29 7/8" (16x86x758)



**M5 | GABLE BOARD - W4L04641**  
(2) | 5/8"x3 3/8"x59 1/2" (16x86x1510)

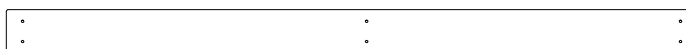

**M6 | CLUB HOUSE WALL BOARD - W4L04635**  
(1) | 5/8"x3 3/8"x53 7/8" (16x86x1370)

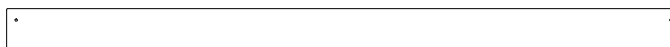

**M7 | GABLE BOARD - W4L04642**  
(2) | 5/8"x3 3/8"x52 5/8" (16x86x1338)

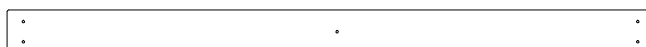

**M8 | FORT WALL BOARD - W4L15914**  
(7) | 5/8"x3 3/8"x50 1/2" (16x86x1284)

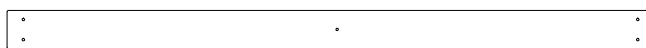

**M9 | FORT WALL BOARD - W4L15915**  
(2) | 5/8"x3"x50 1/2" (16x76x1284)



**M10 | CLUB HOUSE WALL RAIL - W4L04614**  
(1) | 5/8"x3 3/8"x50 1/4" (16x86x1277)

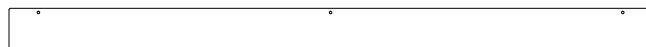

**M11 | SOFFIT CAP - W4L04653**  
(1) | 5/8"x3 3/8"x50 1/4" (16x86x1277)

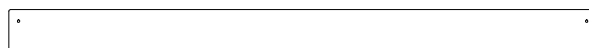

**M12 | GABLE BOARD - W4L04650**  
(1) | 5/8"x3 3/8"x45 7/8" (16x86x1166)



**M13 | PICNIC TABLE TOP - W4L04602**  
(4) | 5/8"x3 3/8"x41 1/4" (16x86x1049)

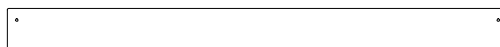

**M14 | GABLE BOARD - W4L04651**  
(1) | 5/8"x3 3/8"x39 1/8" (16x86x994)



**M15 | WALL BOARD - W4L15943**  
(4) | 5/8"x3 3/8"x29 7/8" (16x86x758)

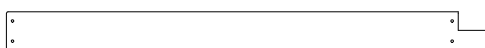

**M16 | CENTER PICNIC TABLE TOP - W4L04603**  
(1) | 5/8"x3"x38 1/4" (16x76x973)



Wood Components (Not to Scale)



**M17** | FRONT WINDOW WALL BOARD - W4L15920  
(2) | 5/8"x3 3/8"x35" (16x86x889)



**M18** | GABLE BOARD - W4L04652  
(1) | 5/8"x3 3/8"x32 3/8" (16x86x822)



**M19** | FRONT PORCH ROOF SUPPORT - W4L04658  
(1) | 5/8"x3 3/8"x30 5/8" (16x86x779)



**M21** | CLUB HOUSE WALL RAIL - W4L04613  
(3) | 5/8"x3 3/8"x30 1/4" (16x86x768)



**M22** | FORT WALL BOARD - W4L15917  
(4) | 5/8"x3 3/8"x29 7/8" (16x86x758)



**M23** | FORT WALL BOARD - W4L15918  
(2) | 5/8"x3 1/8"x29 7/8" (16x80x758)



**M24** | WALL BOARD - W4L04632  
(19) | 5/8"x3 3/8"x29 7/8" (16x86x758)



**M26** | WALL BOARD - W4L04636  
(2) | 5/8"x3 3/8"x26 1/8" (16x86x664)



**M27** | BOTTOM WALL BOARD - W4L15944  
(18) | 5/8"x3 3/8"x21 3/8" (16x86x544)



**M28** | GABLE WINDOW BOARD - W4L04647  
(2) | 5/8"x3 3/8"x19 1/2" (16x86x496)



**M29** | GABLE WINDOW BOARD - W4L04643  
(2) | 5/8"x3 3/8"x16 1/8" (16x86x410)

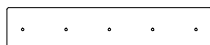

**M30** | PICNIC TABLE TOP CLEAT - W4L04604  
(1) | 5/8"x3 3/8"x16" (16x86x406)

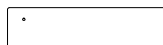

**M31** | GABLE WINDOW BOARD - W4L04644  
(2) | 5/8"x3 3/8"x12 3/4" (16x86x324)



Wood Components (Not to Scale)



**M32** | CROWS NEST WALL RAIL - W4L04671  
(2) | 5/8"x3 3/8"x10" (16x86x254)



**M33** | FRONT WINDOW WALL BOARD - W4L15921  
(2) | 5/8"x3 3/8"x6 3/8" (16x86x162)



**M34** | WALL RAIL - W4L04611  
(1) | 5/8"x3 3/8"x6 3/8" (16x86x162)



**M61** | ATTACHMENT BOARD - W4L15924  
(1) | 5/8"x3 3/8"x22 7/8" (16x86x580)

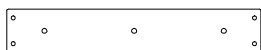

**M70** | SLIDE BED SUPPORT - W100935  
(1) | 5/8"x3 3/8"x19 7/8" (16x86x505)



**M73** | REAR SUPPORT - W4L15930  
(1) | 5/8"x3 3/8"x20 1/8" (16x86x512)



**M74** | ROCK WALL BOARD - W4L15927  
(10) | 5/8"x3 3/8"x22 7/8" (16x86x580)

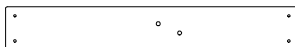

**M75** | ROCK WALL BOARD - W4L15926  
(4) | 5/8"x3 3/8"x22 7/8" (16x86x580)



**M76** | ROCK WALL BOARD - W4L15922  
(4) | 5/8"x3 3/8"x22 7/8" (16x86x580)

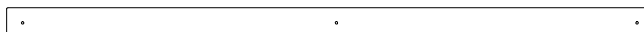

**N1** | FORT WALL BOARD - W4L15913  
(2) | 5/8"x2 3/8"x50 1/2" (16x60x1284)

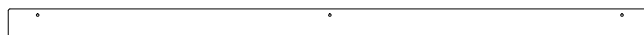

**N2** | SOFFIT CAP - W4L04654  
(1) | 5/8"x2 3/8"x50 1/4" (16x60x1277)

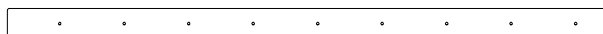

**N3** | ROOF SUPPORT - W103535  
(2) | 5/8"x2 3/8"x47" (16x60x1193)



**N04** | CROWS NEST WALL BOARD - W4L15912  
(2) | 5/8"x2 3/8"x18 1/8" (16x60x461)



**N5** | FRONT PORCH GABLE TRIM - W4L04656  
(1) | 5/8"x2 3/8"x15" (16x60x381)

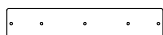

**N6** | WINDOW TRIM - W4L04646  
(2) | 5/8"x2 3/8"x12 1/4" (16x60x310)



Wood Components (Not to Scale)



**N7 | GABLE TRIM - W4L04648**  
(2) | 5/8"x2 3/8"x11 1/2" (16x60x292)



**N8 | FRONT PORCH GABLE TRIM - W4L04657**  
(2) | 5/8"x2 3/8"x9 1/2" (16x60x241)



**N9 | GABLE TRIM - W4L04649**  
(4) | 5/8"x2 3/8"x6 1/2" (16x60x165)



**N10 | GABLE BOARD - W4L04645**  
(2) | 5/8"x2 3/8"x27 5/8" (16x60x702)

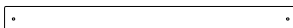

**N11 | ROCK WALL BOARD - W4L15928**  
(1) | 5/8"x2"x22 7/8" (16x50x580)

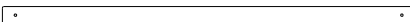

**O1 | CROWS NEST WALL BOARD - W4L15911**  
(18) | 5/8"x1 3/8"x32 1/4" (16x34x819)



**O2 | SAFETY BOARD - W4L04605**  
(1) | 5/8"x1 3/8"x28 5/8" (16x34x726)



**SP1 | SWING BEAM SUPPORT - W4L15891**  
(1) | 3 3/8"x3 3/8"x48 3/8" (86x86x1229)

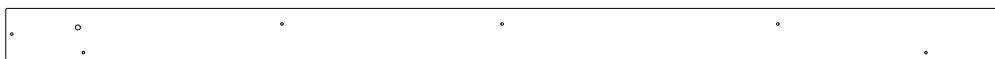

**Y1 | TOP FLOOR BOARD - W4L15964**  
(2) | 5/8"x4"x78" (16x102x1980)

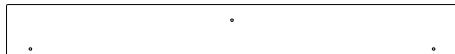

**Y2 | BOTTOM FLOOR BOARD - W4L04577**  
(2) | 5/8"x4"x35 1/4" (16x102x895)



**Y3 | ROCK WALL END BOARD - W4L15925**  
(1) | 5/8"x3 5/8"x22 7/8" (16x92x580)



**FP1 | BOTTOM FLOOR PANEL - W2A01485**  
(4) | 1 5/8"x13 1/2"x35 3/8" (40x344x897)

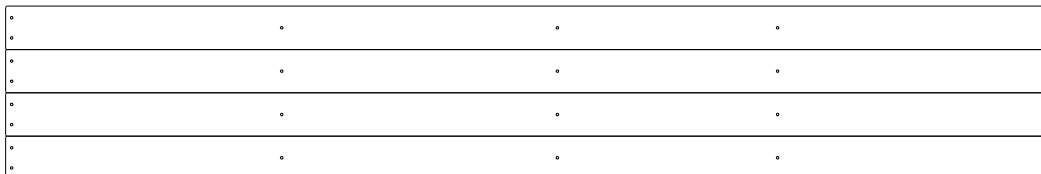

**FP2 | FLOOR PANEL - W2A03345**  
(4) | 1 1/4"x13 1/2"x81 7/8" (32x344x2080)

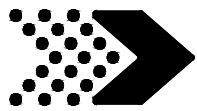

Wood Components (Not to Scale)

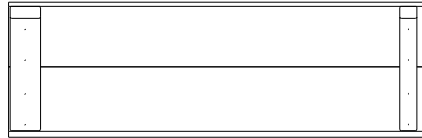

**RP1** | LEFT PORCH PEAK ROOF PANEL - W2A02630  
(1) | 1 5/8"x10 1/2"x32 7/8" (42x268x834)

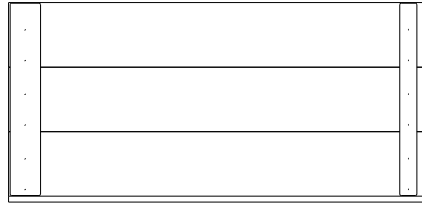

**RP2** | LEFT PORCH ROOF PANEL - W2A02628  
(1) | 1 5/8"x15 5/8"x32 7/8" (42x396x834)



**RP3** | PEAK ROOF PANEL - W2A02626  
(2) | 1 5/8"x20 5/8"x59" (42x524x1499)

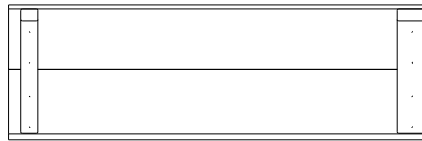

**RP4** | RIGHT PORCH PEAK ROOF PANEL - W2A02631  
(1) | 1 5/8"x10 1/2"x32 7/8" (42x268x834)

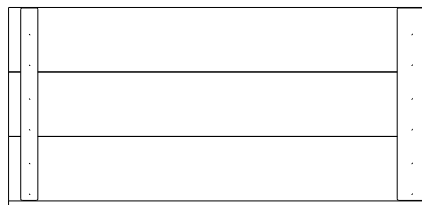

**RP5** | RIGHT PORCH ROOF PANEL - W2A02629  
(1) | 1 5/8"x15 5/8"x32 7/8" (42x396x834)



**RP6** | ROOF PANEL - W2A02627  
(4) | 1 5/8"x15 5/8"x59" (42x396x1499)

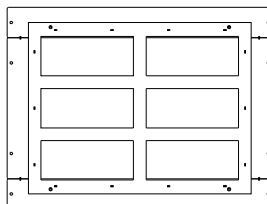

**WP1** | BAY WINDOW PANEL - W2A01496  
(6) | 7/8"x15 3/4"x20 3/4" (21x400x526)

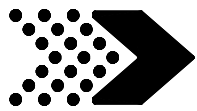

Hardware Components

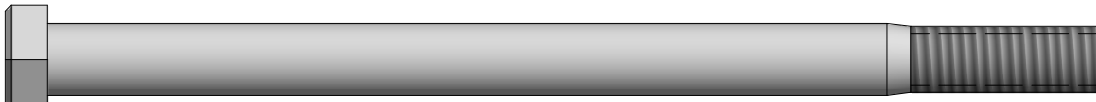

**H100654** | BOLT HEX  
(13) | 3/8x5-1/2

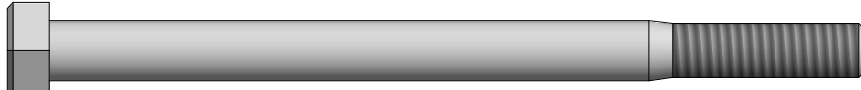

**H100054** | BOLT HEX  
(2) | 5/16x4 1/4

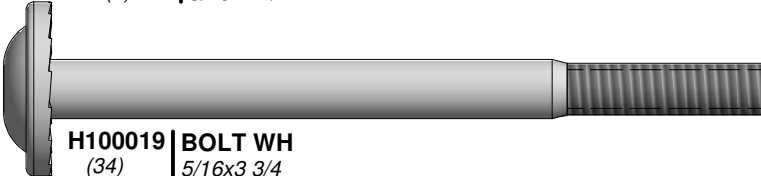

**H100019** | BOLT WH  
(34) | 5/16x3 3/4

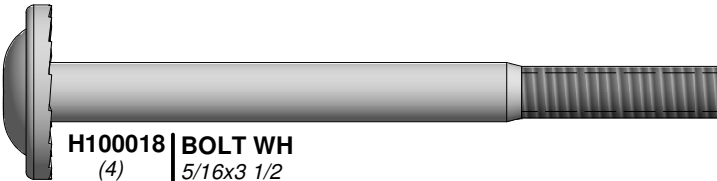

**H100018** | BOLT WH  
(4) | 5/16x3 1/2

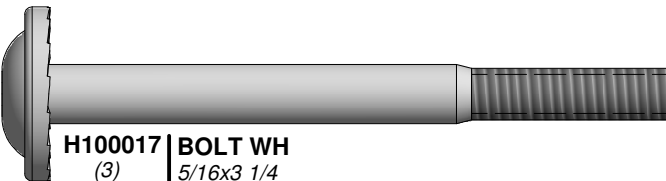

**H100017** | BOLT WH  
(3) | 5/16x3 1/4

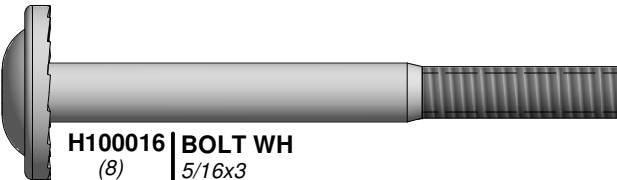

**H100016** | BOLT WH  
(8) | 5/16x3

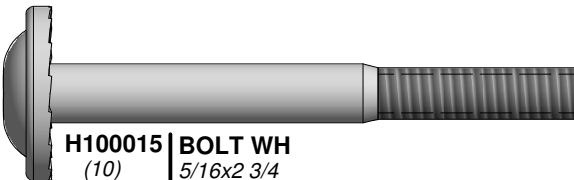

**H100015** | BOLT WH  
(10) | 5/16x2 3/4

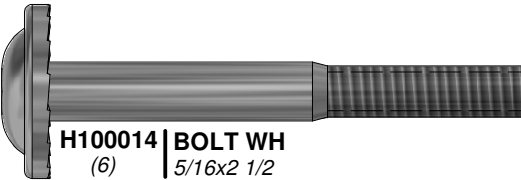

**H100014** | BOLT WH  
(6) | 5/16x2 1/2

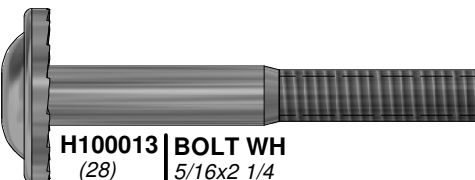

**H100013** | BOLT WH  
(28) | 5/16x2 1/4

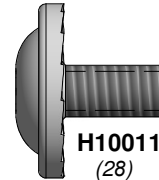

**H100115** | BOLT WH  
(28) | 5/16x1/2

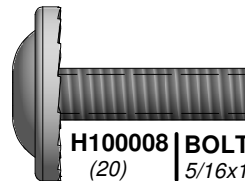

**H100008** | BOLT WH  
(20) | 5/16x1

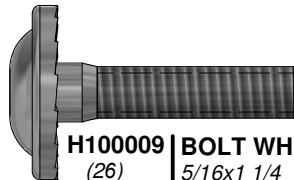

**H100009** | BOLT WH  
(26) | 5/16x1 1/4

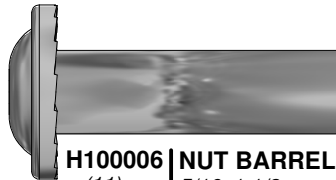

**H100006** | NUT BARREL WH  
(11) | 5/16x1 1/2

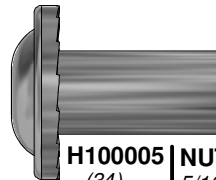

**H100005** | NUT BARREL WH  
(34) | 5/16x7/8

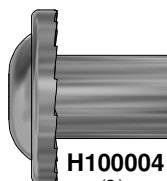

**H100004** | NUT BARREL WH  
(2) | 5/16 x 5/8

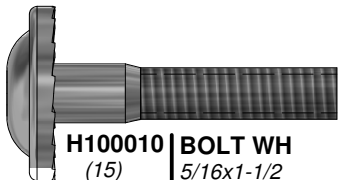

**H100010** | BOLT WH  
(15) | 5/16x1-1/2

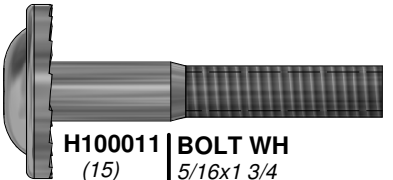

**H100011** | BOLT WH  
(15) | 5/16x1 3/4



**H100012** | BOLT WH  
(9) | 5/16x2





Hardware Components



H100764 | SCREW SETTER  
(1)

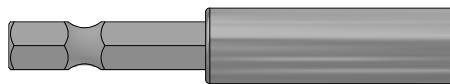

H101100 | MAGNETIC DRIVER  
(1)



H100147 | TORX BIT  
(1) | T-30

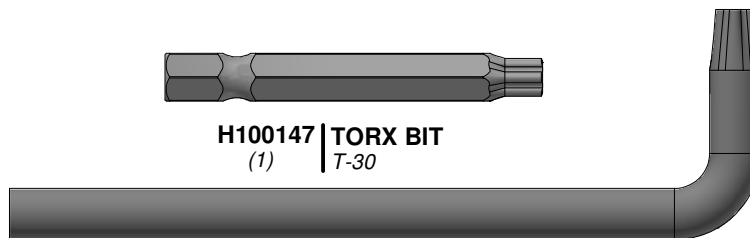

H100114 | TORX WRENCH  
(1) | T-30



H100047 | BOLT HEX  
(2) | 5/16x2 3/4

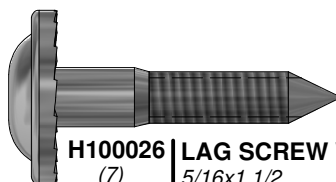

H100026 | LAG SCREW WH  
(7) | 5/16x1 1/2

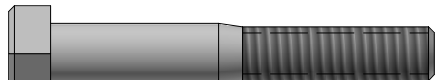

H100044 | BOLT HEX  
(4) | 5/16x2

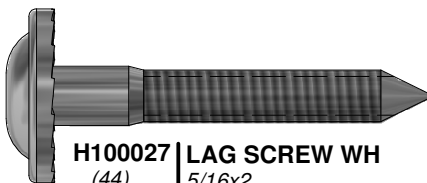

H100027 | LAG SCREW WH  
(44) | 5/16x2



H100043 | BOLT HEX  
(4) | 5/16x1 3/4



H100028 | LAG SCREW WH  
(36) | 5/16x2 1/2



H100042 | BOLT HEX  
(4) | 5/16x1 1/4



H100649 | LAG SCREW WH  
(11) | 1/4x2 1/2

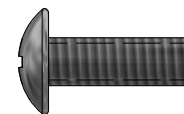

H100063 | BOLT PTH  
(26) | 1/4x3/4



H100146 | LAG SCREW WH  
(2) | 1/4x2



H100145 | LAG SCREW WH  
(30) | 1/4x1 1/2



H100070 | SCREW PWH  
(9) | 8x3/4

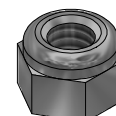

H100110 | NUT LOCK  
(4) | 5/16



H100066 | LAG SCREW  
(9) | 5/16x1 1/2



H100128 | SCREW PWH  
(33) | 8x5/8

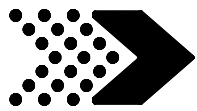

Hardware Components



**H100090 | SCREW PFH**  
(51) | 8x2 1/2"



**H100091 | SCREW PFH**  
(35) | 8X2 1/4



**H100111 | SCREW PFH**  
(88) | 8x2



**H100089 | SCREW PFH**  
(4) | 8x1 3/4



**H100086 | SCREW PFH**  
(360) | 8x1 1/2



**H100087 | SCREW PFH**  
(4) | 8x1 1/4



**H100088 | SCREW PFH**  
(401) | 8x1 1/8



**H100085 | SCREW PFH**  
(9) | 8x1

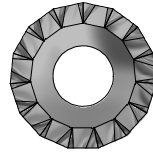

**H100030 | WASHER LOCK EXT**  
(187) | 8x19

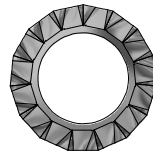

**H100031 | WASHER LOCK EXT**  
(34) | 12x19

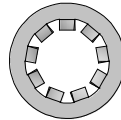

**H100108 | WASHER LOCK INT**  
(28) | 8x15

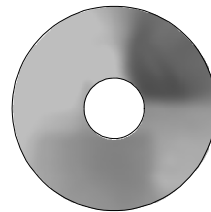

**H100105 | WASHER FLAT**  
(28) | 8x27

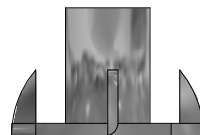

**H100073 | T-NUT**  
(13) | 3/8

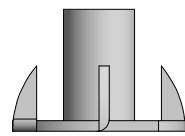

**H100074 | T-NUT**  
(152) | 5/16

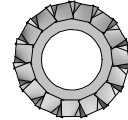

**H100138 | WASHER LOCK EXT**  
(13) | 6x15

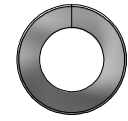

**H100095 | WASHER SPLIT**  
(22) | 5/16

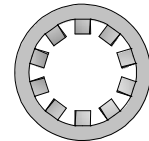

**H100107 | WASHER LOCK INT**  
(13) | 10x18

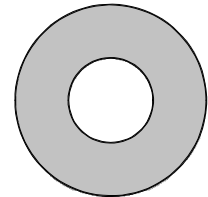

**H100102 | WASHER FLAT**  
(13) | 11x25

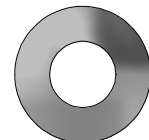

**H100106 | WASHER FLAT**  
(11) | 9x18

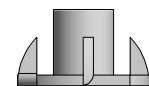

**H100072 | T-NUT**  
(26) | 1/4



Accessory Components (Not to Scale)

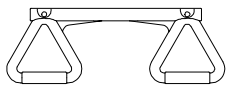

A6P00034 (1) | TRAPEZE YELLOW

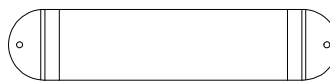

A100027 (2) | SWING SEAT GREEN 26"

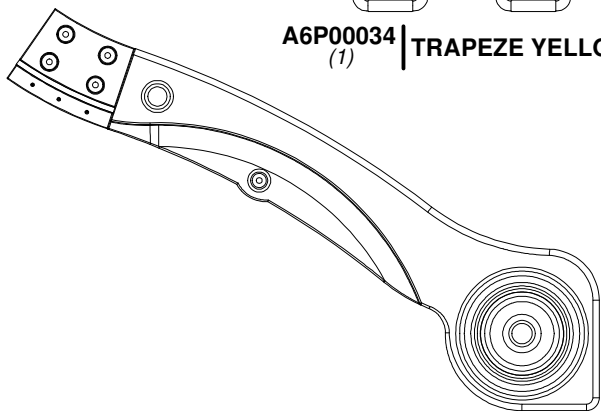

A6P00483 (1) | SLIDE RAIL 10' BOTTOM LEFT GREEN

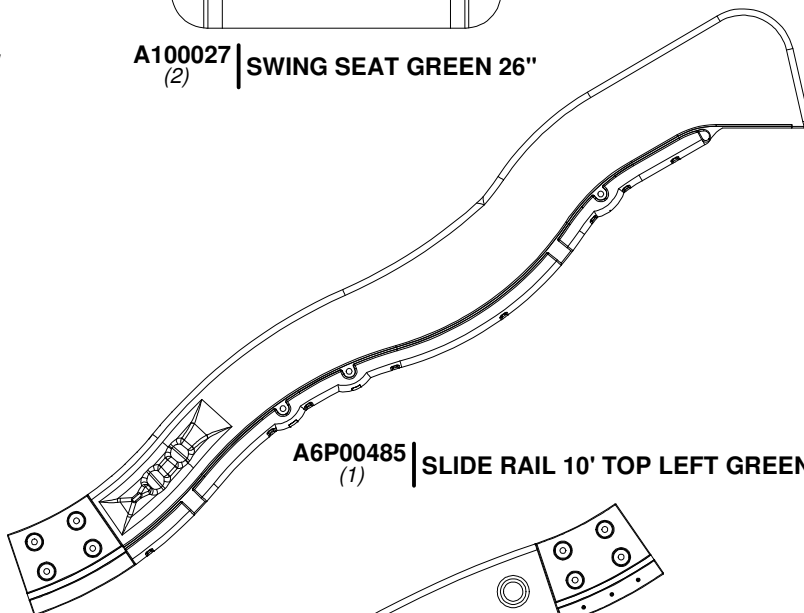

A6P00485 (1) | SLIDE RAIL 10' TOP LEFT GREEN

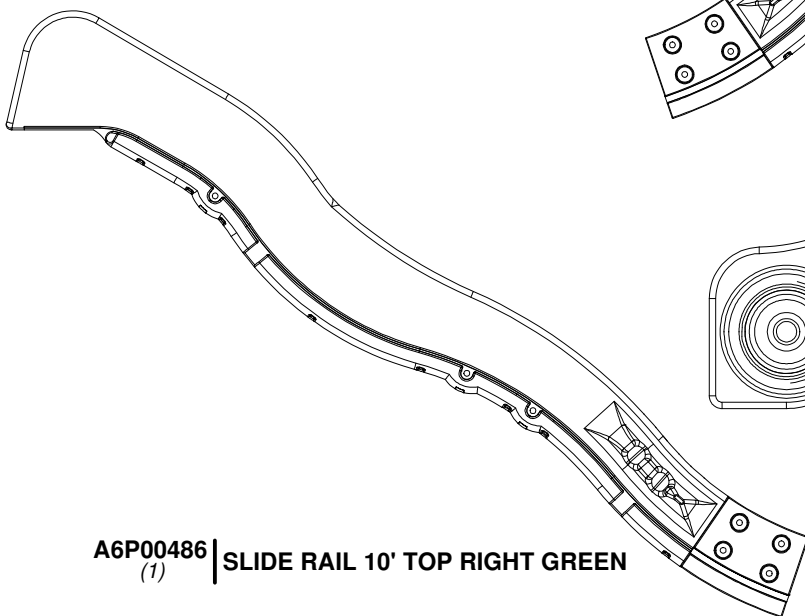

A6P00486 (1) | SLIDE RAIL 10' TOP RIGHT GREEN

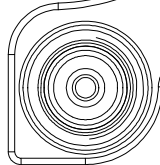

A6P00484 (1) | SLIDE RAIL 10' BOTTOM RIGHT GREEN



A6P00036 (6) | GREEN HC ROCK #1



A6P00037 (6) | GREEN HC ROCK #2

A100035 (1) | SLIDE BED 10' LIGHT GREEN



A6P00487-DNU (4) | SLIDE SUPPORT TUBE



A100164 (1) | BYD ID TAG (LARGE) AGES 3-10



A100045 (8) | METAL RUNG 559 GREEN



Accessory Components (Not to Scale)



A100047 | CHAIN GREEN 57"  
(4)



A100177 | CHAIN GREEN 31"  
(2)

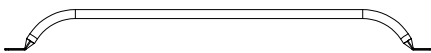

A100134 | HAND GRIP GREEN 816 C/C  
(2)

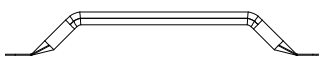

A100324 | LADDER RUNG 578 GREEN  
(2)



A100140 | L BRACKET 66x66x127  
(2)

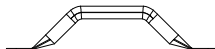

A100118 | HAND GRIP METAL GREEN 381 c/c  
(6)



A100069 | QUICK LINK  
(6)

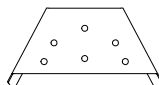

A4M01169 | A-FRAME BRACKET  
(1)

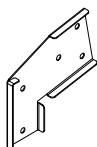

A100325 | SWING BEAM  
EXTENSION  
BRACKET-LEFT  
(1)

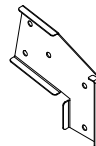

A100326 | SWING BEAM  
EXTENSION  
BRACKET-RIGHT  
(1)



A100314 | "A" REVISION TAG  
(1)

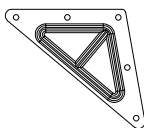

A100294 | TRIANGLE  
PLATE 100° 5  
HOLE  
(2)

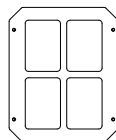

A100146 | WINDOW 216x267 GREEN  
(2)

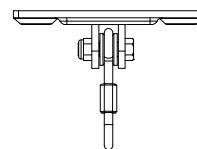

A4M00505 | SWING HANGER  
(6)



A100396 | L BRACKET  
51x32x82x3.175  
(4)



A100178 | AUGER GROUND STAKE  
(8)



A4M01046 | L BRACKET  
2.5x38x55x55  
(15)



A4M00527 | GROUND STAKE REBAR  
(2)

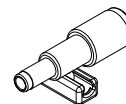

A6P00096 | TELESCOPE  
(1)



**E77** | LEFT UPRIGHT - W4L15932  
(1) | 1 3/8"x3 3/8"x64 3/8" (36x86x1634)



**H76** | LADDER RUNG - W4L15931  
(5) | 1"x3 3/8"x18 1/8" (24x86x460)



**H100111** | SCREW PFH  
(10) | 8x2

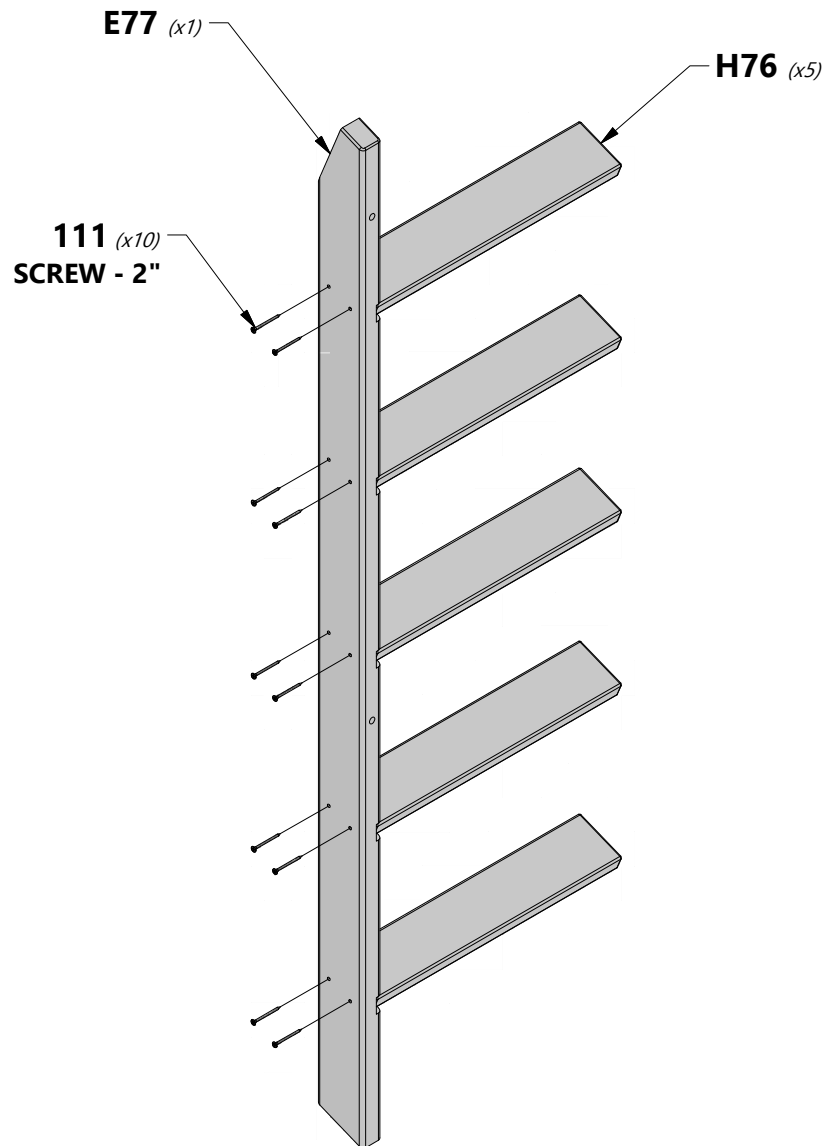

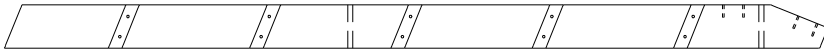

**E78** | RIGHT UPRIGHT - W4L15933  
(1) | 1 3/8"x3 3/8"x64 3/8" (36x86x1634)



**H100111** | SCREW PFH  
(10) | 8x2

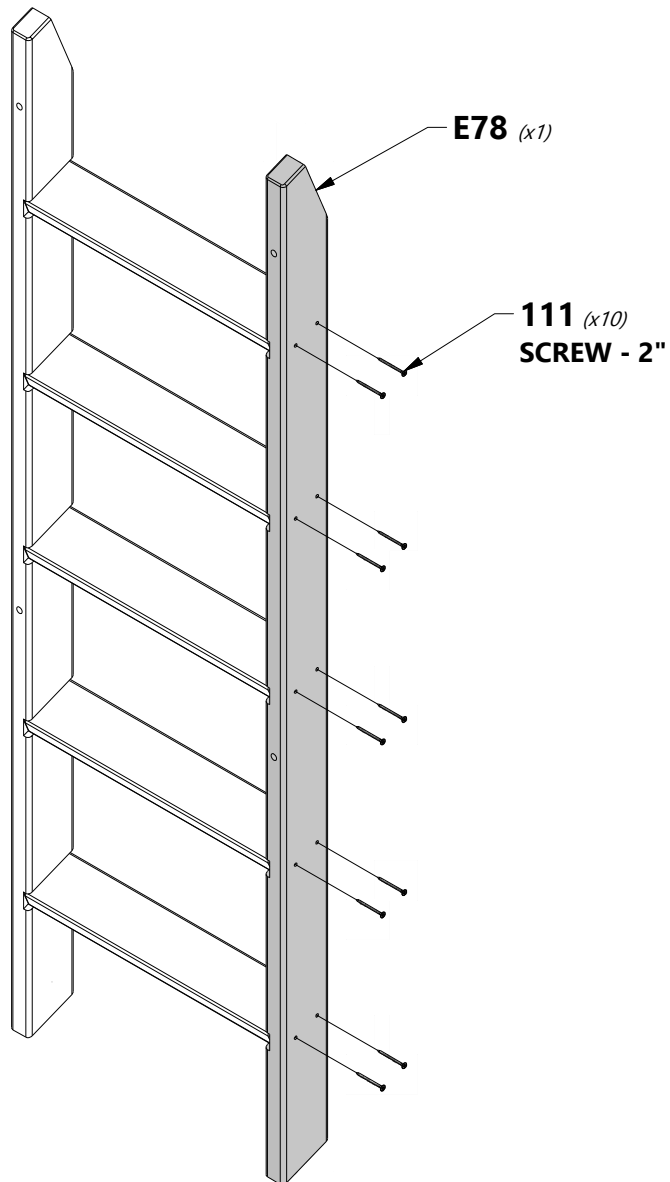



**H77** | ATTACHMENT BOARD - W4L15929  
(1) | 1"x3 3/8"x20 1/8" (24x86x512)



**M73** | REAR SUPPORT - W4L15930  
(1) | 5/8"x3 3/8"x20 1/8" (16x86x512)



**H100111** | SCREW PFH  
(8) | 8x2

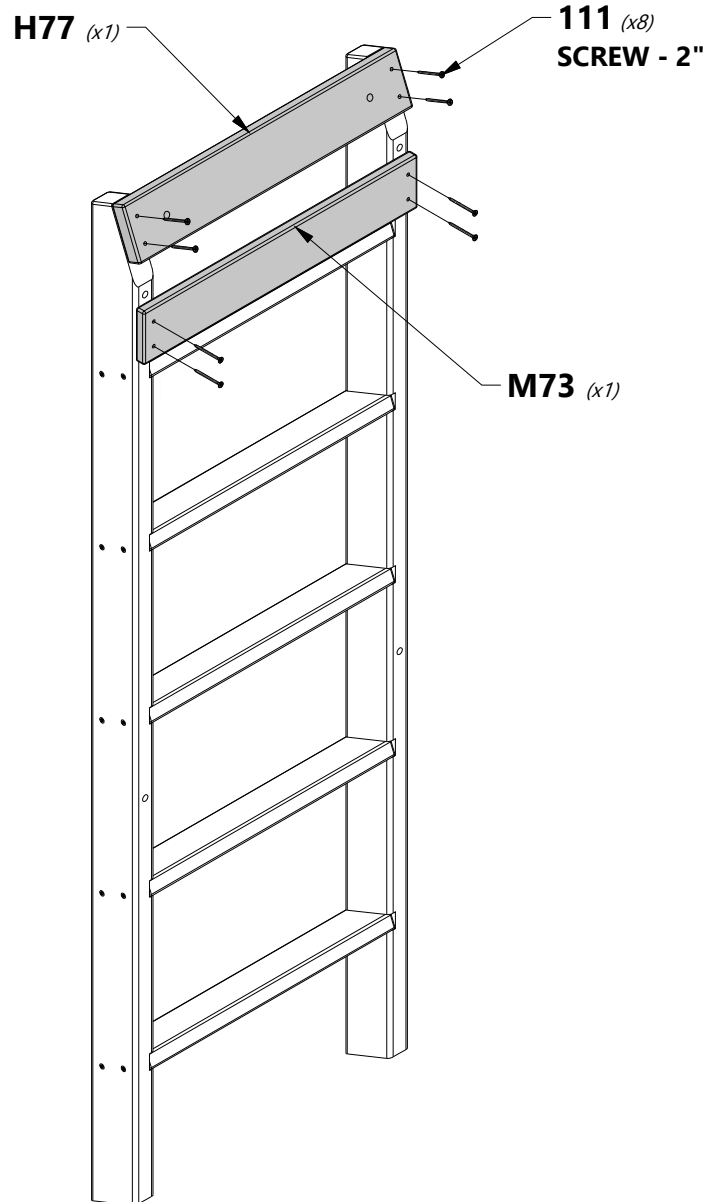

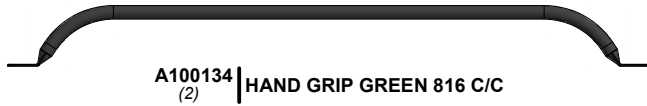

**A100134**  
(2) | **HAND GRIP GREEN 816 C/C**

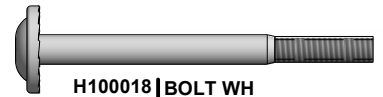

**H100018** | **BOLT WH**  
(4) | **5/16x3 1/2**



**H100074** | **T-NUT**  
(4) | **5/16**



**TIP:**  
INSTALL T-NUTS INTO BOARDS  
BEFORE ASSEMBLY

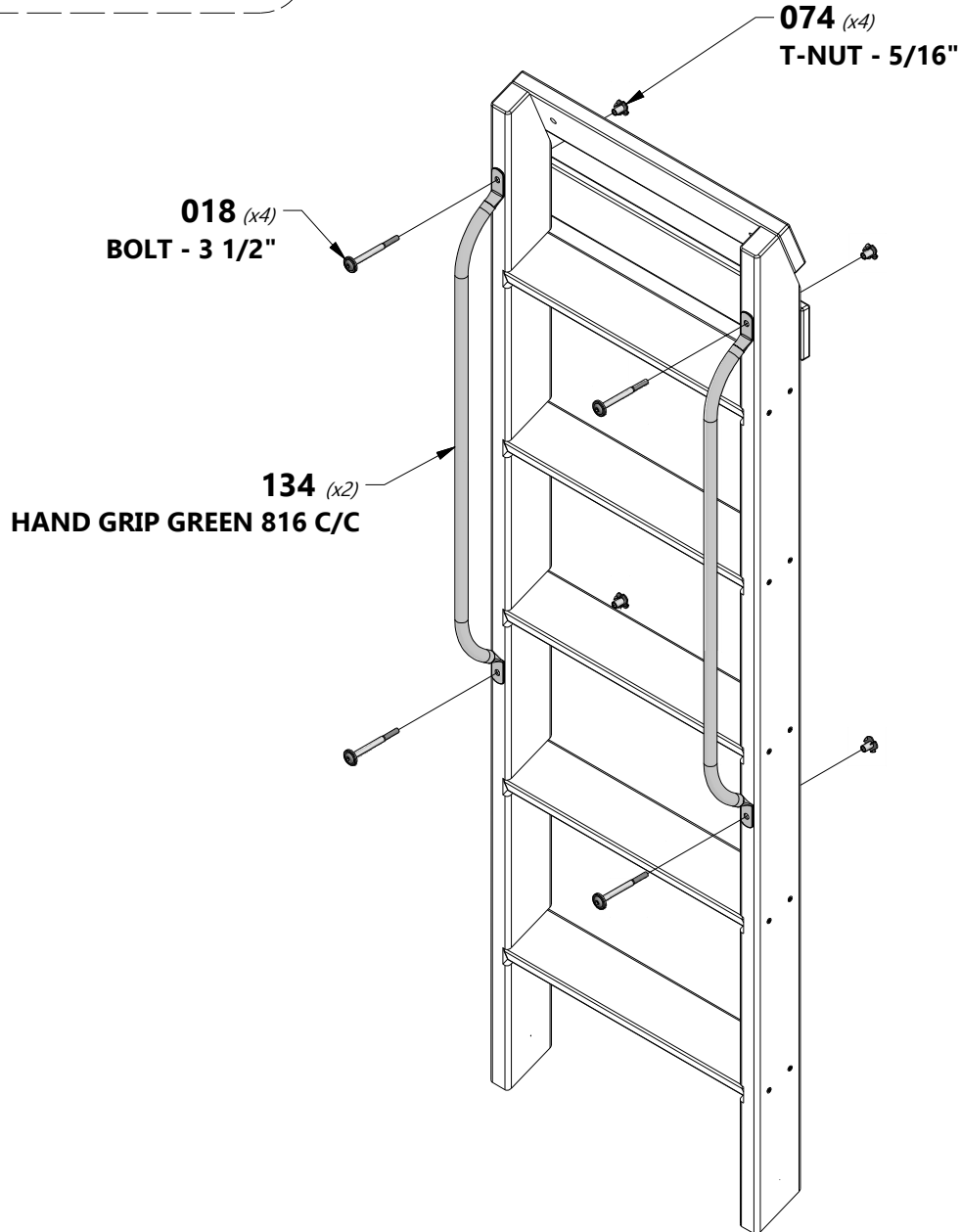





# ROCKWALL ASSEMBLY

## STEP 1



**M76** | ROCK WALL BOARD - W4L15922  
(4) 5/8"x3 3/8"x22 7/8" (16x86x580)



**M75** | ROCK WALL BOARD - W4L15926  
(4) 5/8"x3 3/8"x22 7/8" (16x86x580)

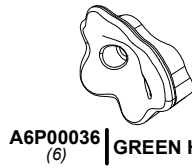

**A6P00036** | GREEN HC ROCK #1  
(6)



**A6P00037** | GREEN HC ROCK #2  
(6)



**H100108** | WASHER LOCK  
(24) INT  
8x15



**H100063** | BOLT PTH  
(24) 1/4x3/4



**H100072** | T-NUT  
(24) 1/4

**TIP:**  
INSTALL T-NUTS INTO BOARDS BEFORE ASSEMBLY

INSTALL WITH FINGER GRIPS UPWARD.  
**\*\*PLACE ROCKS AS DESIRED\*\***

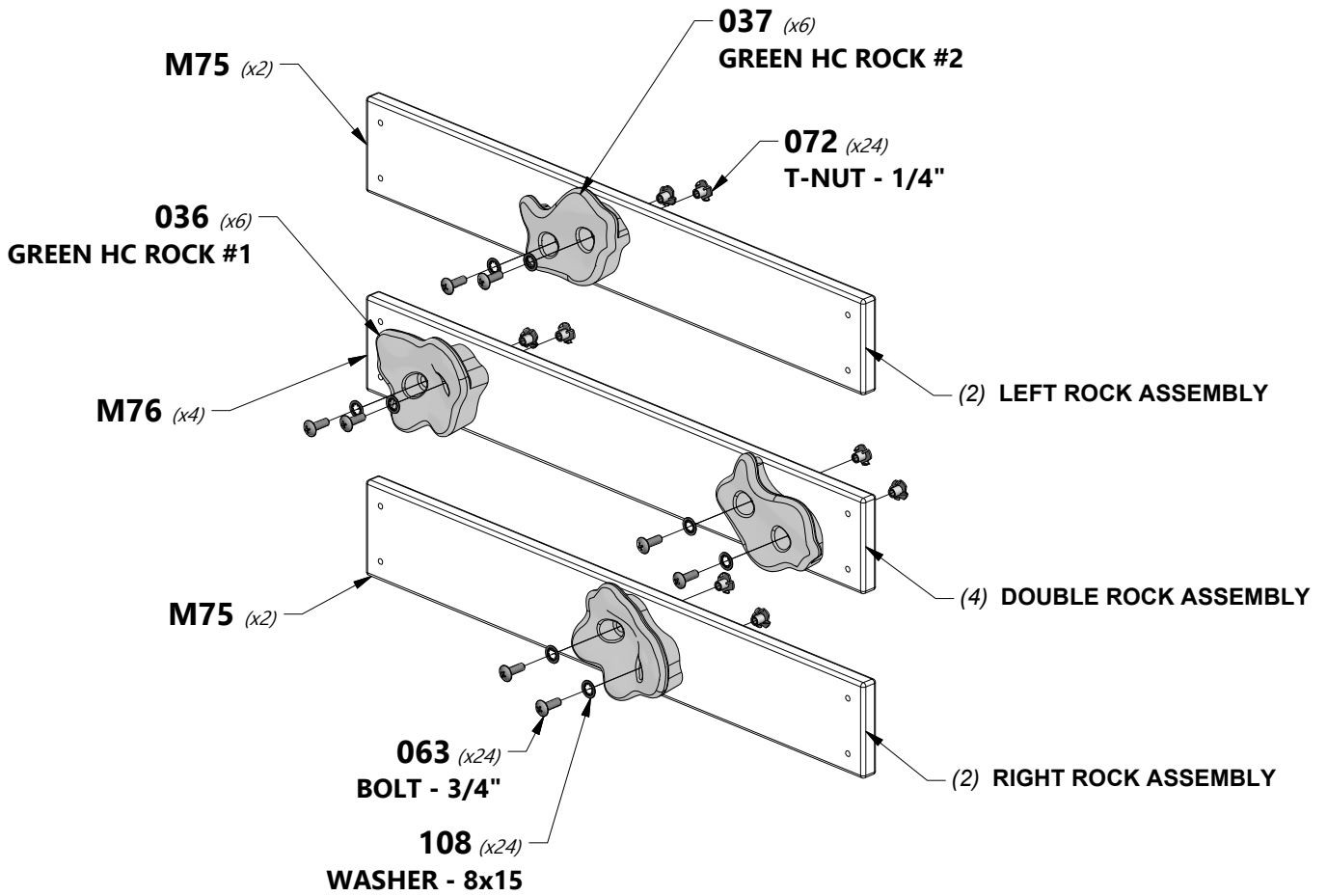
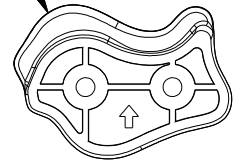
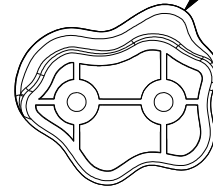



# ROCKWALL ASSEMBLY

## STEP 2

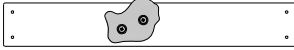

(2) LEFT ROCK ASSEMBLY

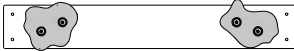

(4) DOUBLE ROCK ASSEMBLY

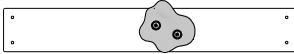

(2) RIGHT ROCK ASSEMBLY

**N11** ROCK WALL BOARD - W4L15928  
(1) 5/8"x2"x22 7/8" (16x50x580)

**M74** ROCK WALL BOARD - W4L15927  
(10) 5/8"x3 3/8"x22 7/8" (16x86x580)

**E72** ROCKWALL RAIL - W4L15923  
(2) 1 3/8"x3 3/8"x64 5/8" (36x86x1640)



**H100086** SCREW PFH  
(74) 8x1 1/2

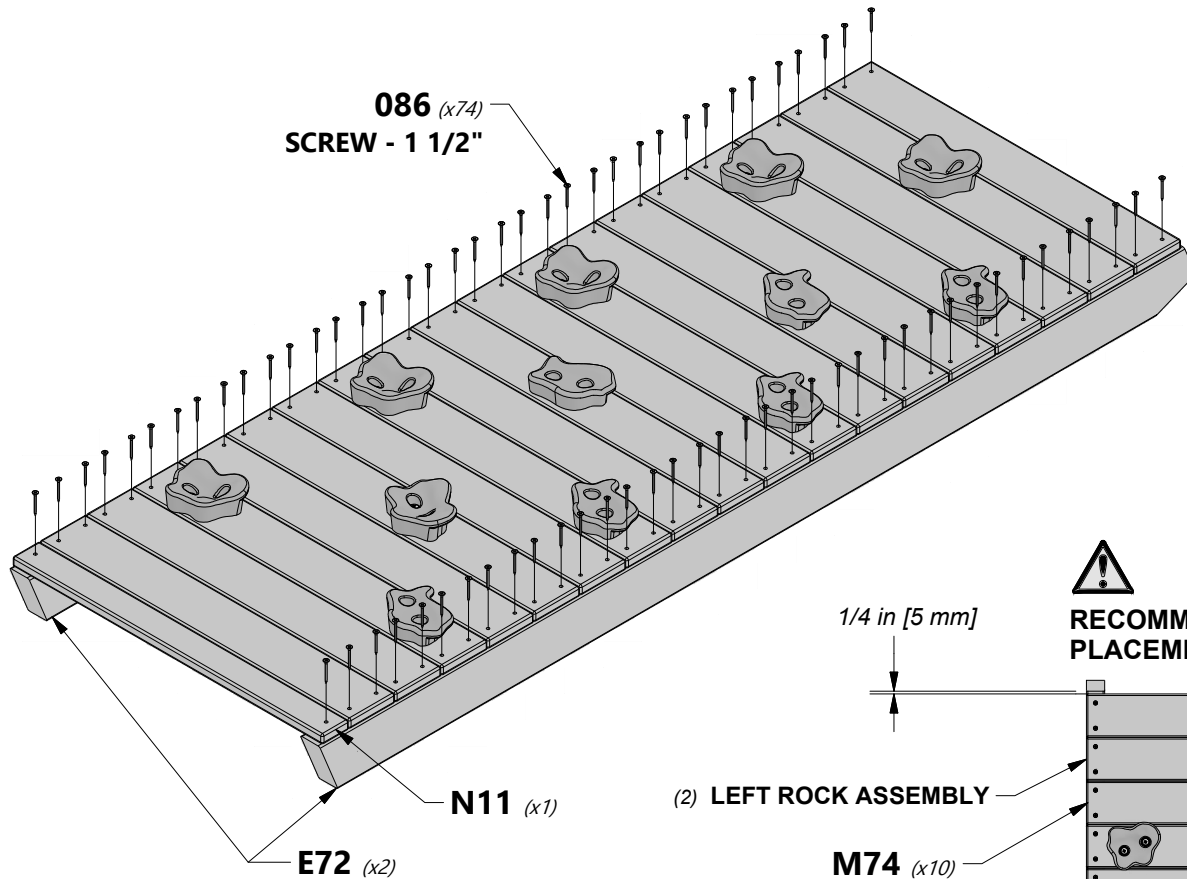

**086** (x74)  
SCREW - 1 1/2"

**N11** (x1)

**E72** (x2)

(2) LEFT ROCK ASSEMBLY

**M74** (x10)

(2) RIGHT ROCK ASSEMBLY

(4) DOUBLE ROCK ASSEMBLY



TOP

RECOMMENDED BOARD  
PLACEMENT PATTERN

1/4 in [5 mm]

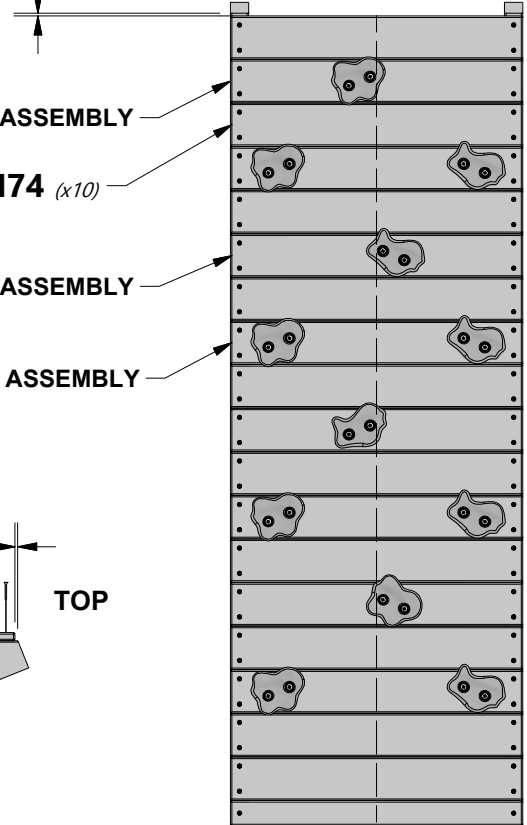

1/4 in [5 mm]

TOP

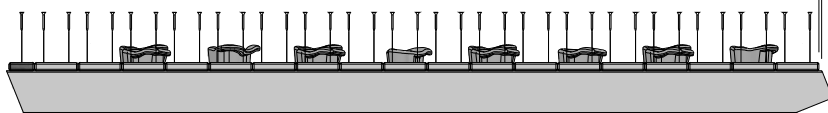

SIDE VIEW



# ROCKWALL ASSEMBLY

## STEP 3



**Y3** | ROCK WALL END BOARD - W4L15925  
(1) | 5/8"x3 5/8"x22 7/8" (16x92x580)



**H100086** | SCREW PFH  
(4) | 8x1 1/2

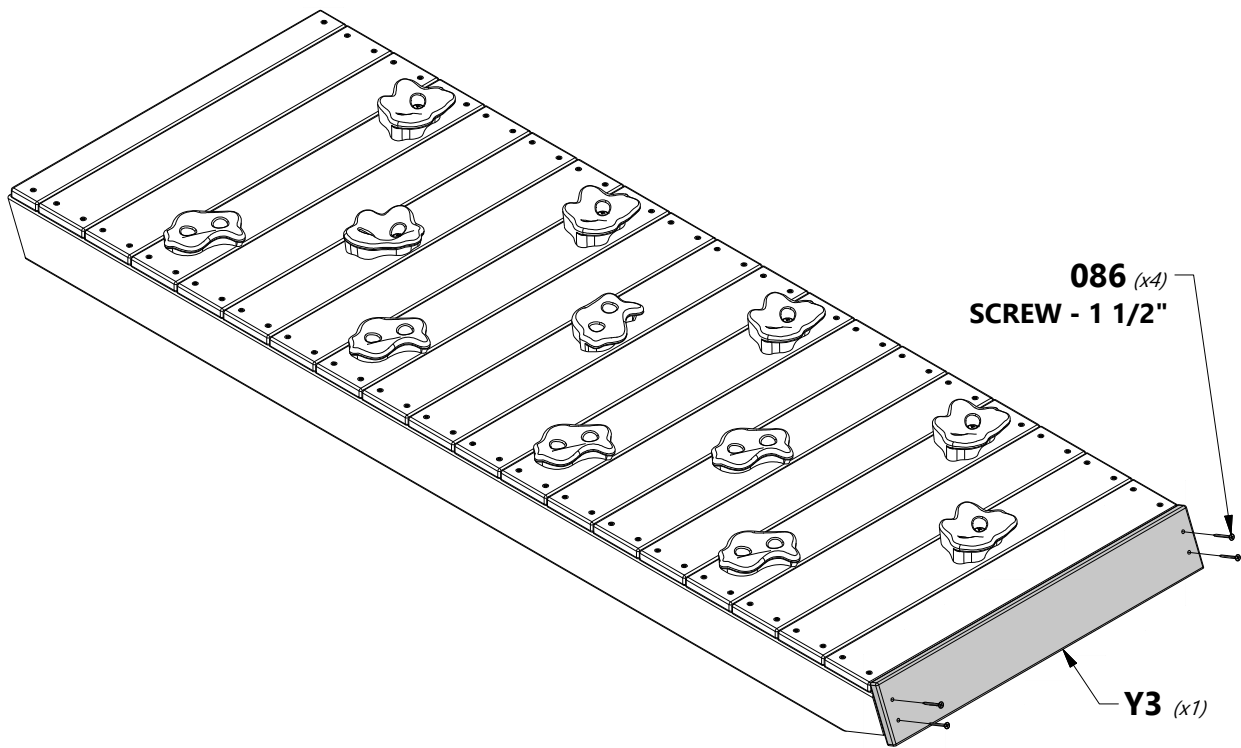

**086** (x4)  
SCREW - 1 1/2"

**Y3** (x1)

### SIDE VIEW

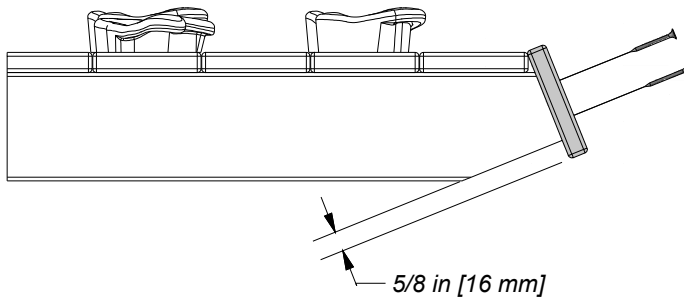

5/8 in [16 mm]



# ROCKWALL ASSEMBLY

## STEP 4



**M61 | ATTACHMENT BOARD - W4L15924**  
(1) | 5/8"x3 3/8"x22 7/8" (16x86x580)



**H100086 | SCREW PFH**  
(4) | 8x1 1/2"



**H100074 | T-NUT**  
(2) | 5/16"



**TIP:**  
INSTALL T-NUTS INTO BOARDS  
BEFORE ASSEMBLY

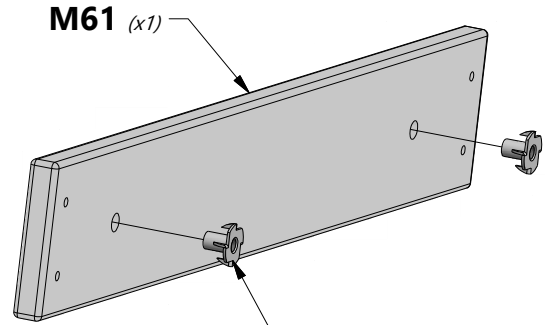

**M61 (x1)**

**074 (x2)**  
**T-NUT - 5/16"**

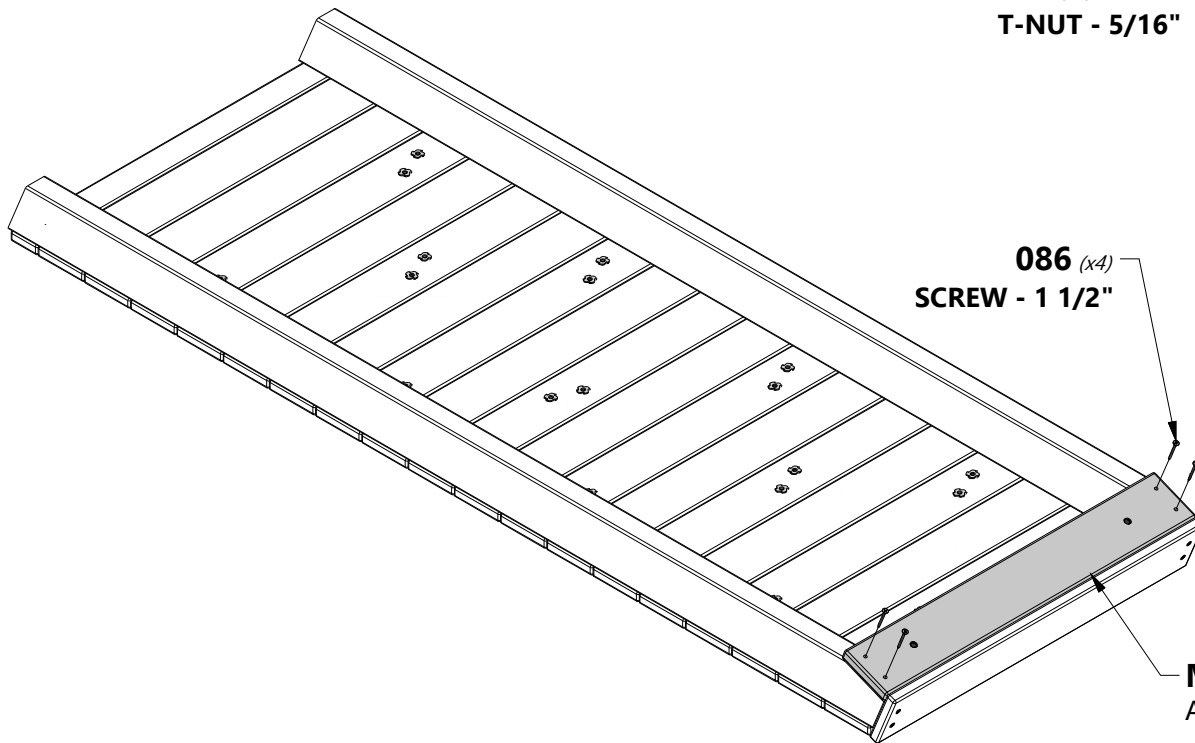

**086 (x4)**  
**SCREW - 1 1/2"**

**M61**  
**ASSEMBLY**

**SIDE VIEW**

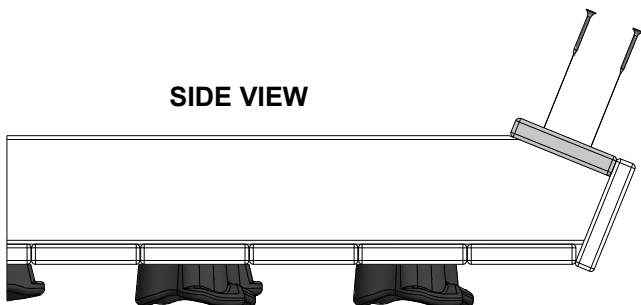

**T-NUTS TO THE INSIDE  
WHEN INSTALLING BOARD**



# CROWS NEST

## STEP 1

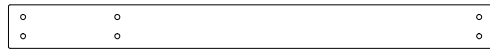

**E03** | CROWS NEST FLOOR RAIL - W4L15901  
(2) | 1 3/8"x3 3/8"x38" (36x86x964)

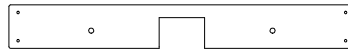

**H19** | CROWS NEST FLOOR RAIL - W4L15903  
(1) | 1"x3 3/8"x27" (24x86x686)

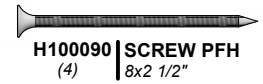

**H100090** | SCREW PFH  
(4) | 8x2 1/2"

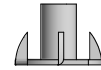

**H100074** | T-NUT  
(4) | 5/16"

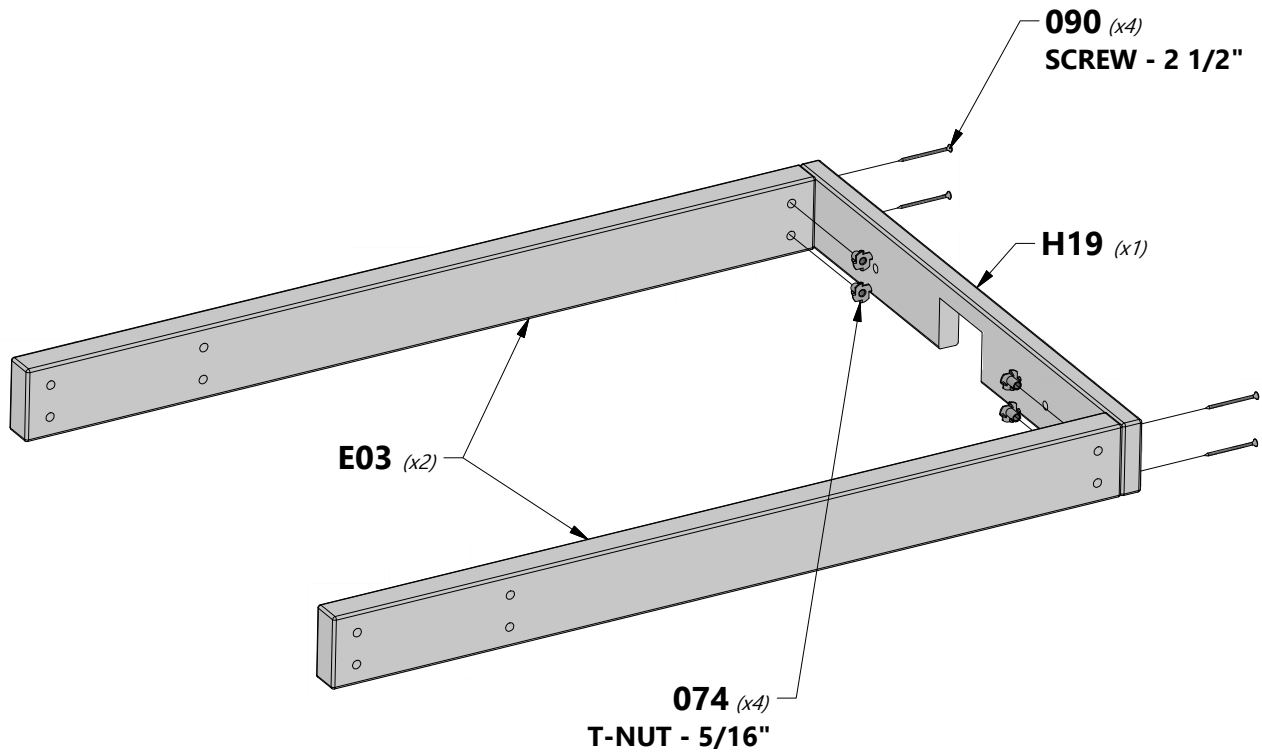



# CROWS NEST

## STEP 2

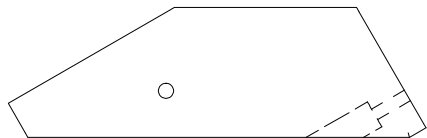

**E8** | CROWS NEST DECK BRACE - W4L15902  
(2) | 1 7/16"x3 3/8"x10 7/8" (36x86x276)

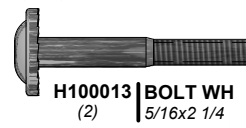

**H100013** | BOLT WH  
(2) | 5/16x2 1/4



**H100074** | T-NUT  
(2) | 5/16



**H100030** | WASHER LOCK EXT  
(2) | 8x19



**TIP:**  
INSTALL T-NUTS INTO  
BOARDS BEFORE ASSEMBLY.

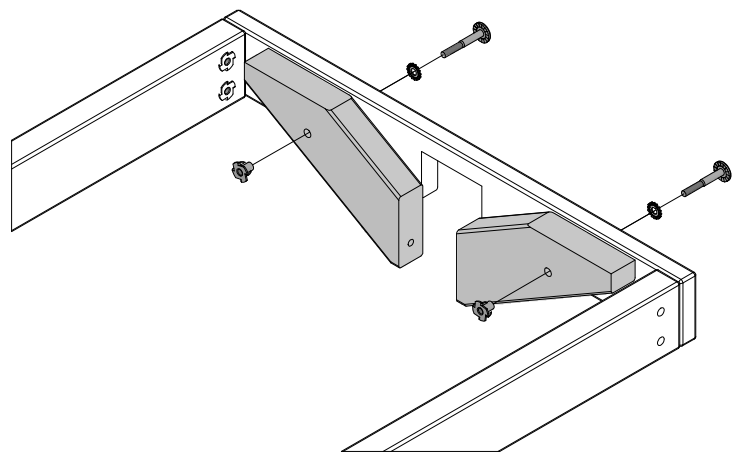

**INSIDE VIEW**

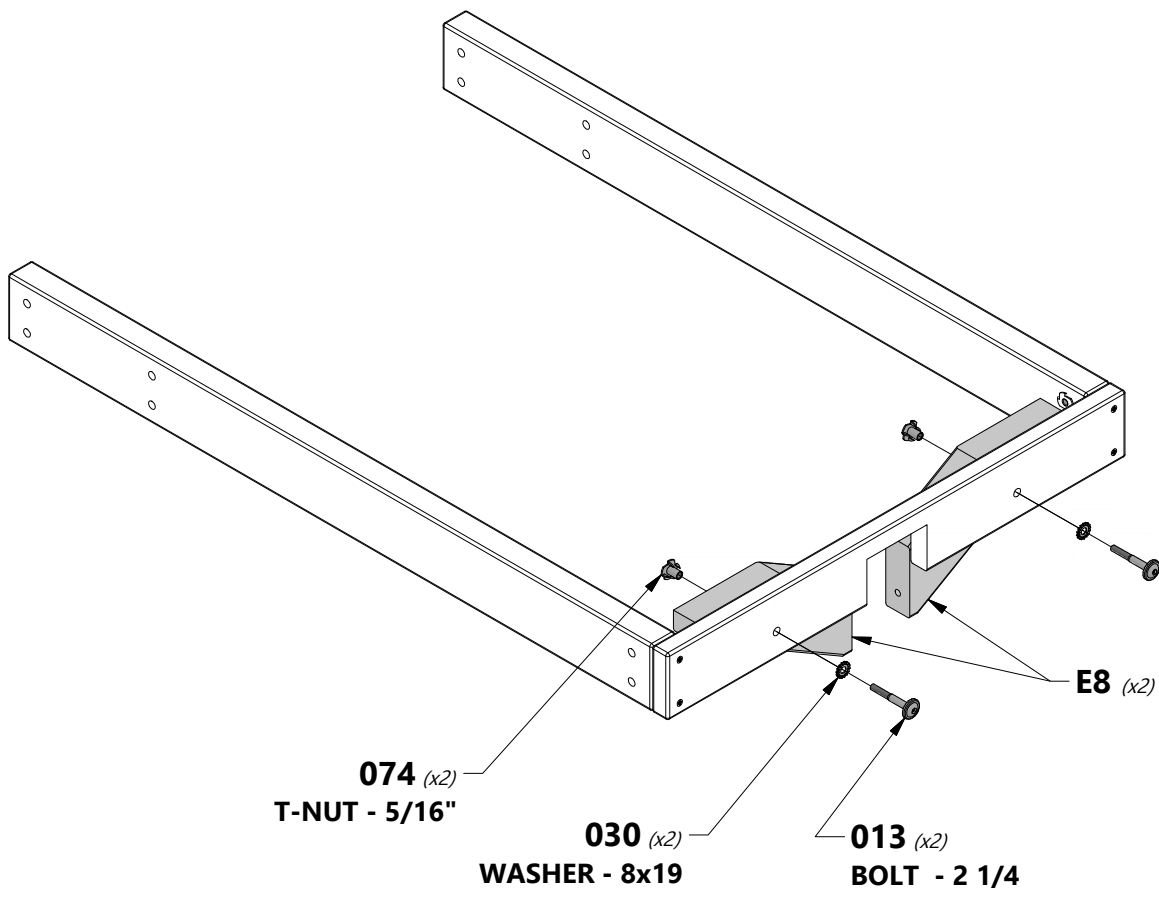

**074 (x2)**  
T-NUT - 5/16"

**030 (x2)**  
WASHER - 8x19

**013 (x2)**  
BOLT - 2 1/4

**E8 (x2)**



# CROWS NEST

## STEP 3



**L01 | CROWS NEST FLOOR BOARD - W4L15905**  
(7) | 5/8"x4 3/8"x27" (16x112x686)



**L03 | CROWS NEST FLOOR BOARD - W4L15906**  
(2) | 5/8"x4 3/8"x27" (16x112x686)



**H100086 | SCREW PFH**  
(34) | 8x1 1/2

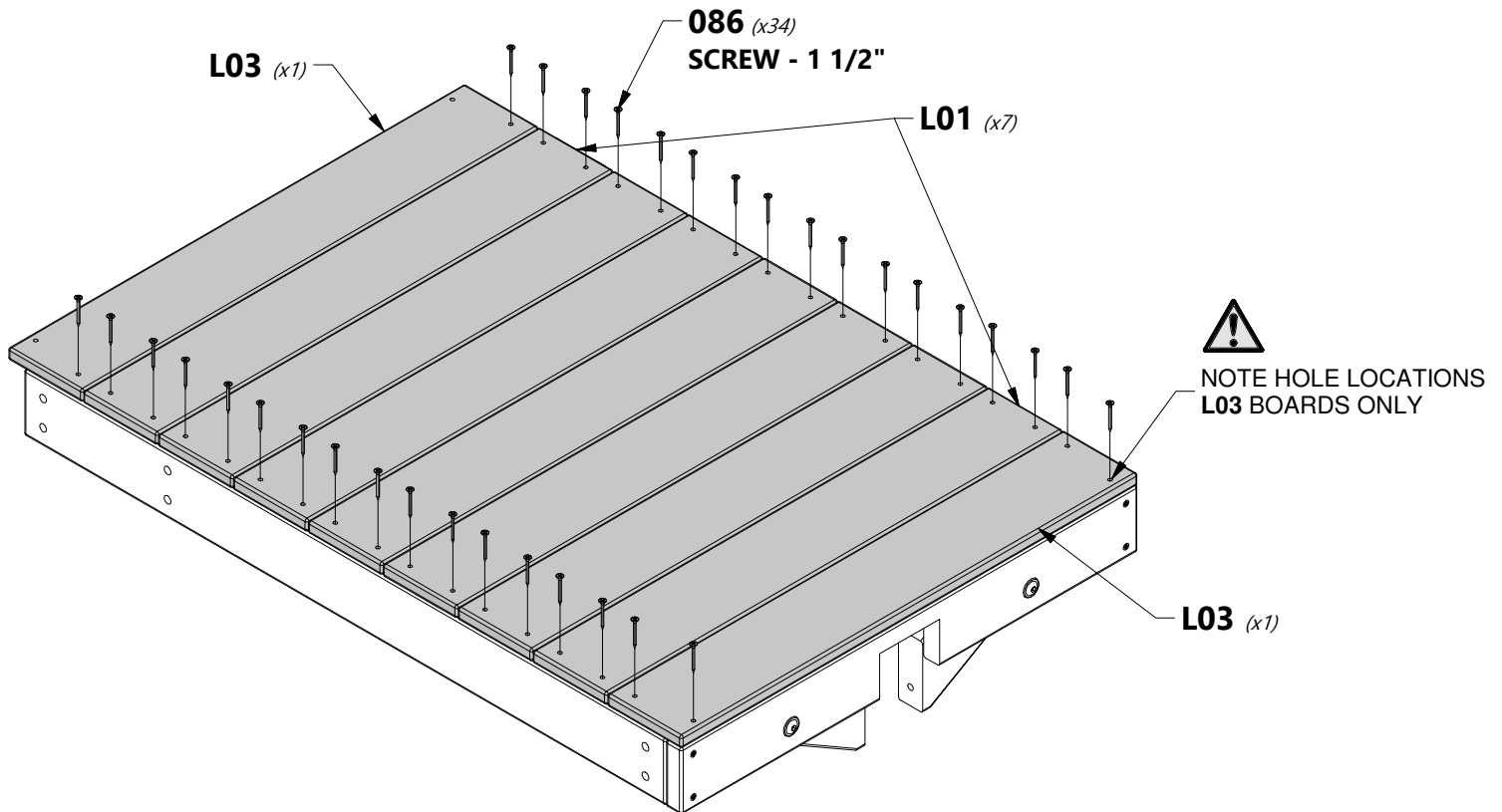
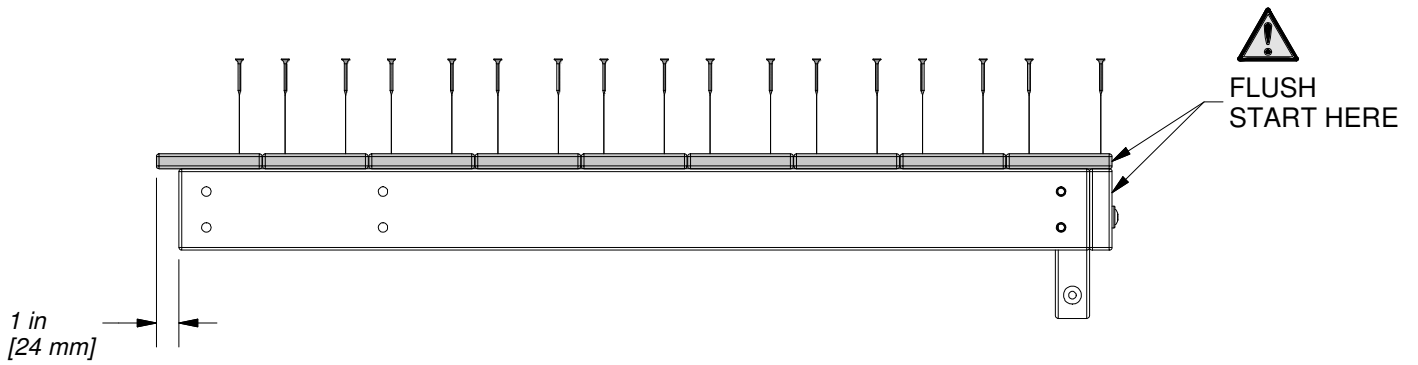





**H21 | CROWS NEST FLOOR SUPPORT - W4L15904**  
(1) | 1"x3 3/8"x24 1/8" (24x86x614)

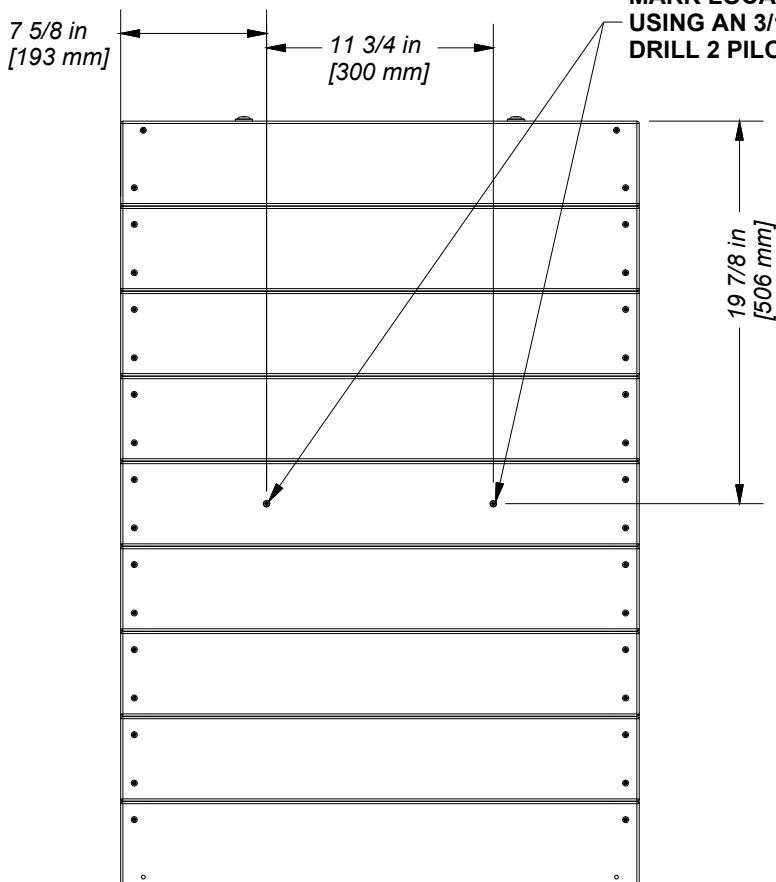
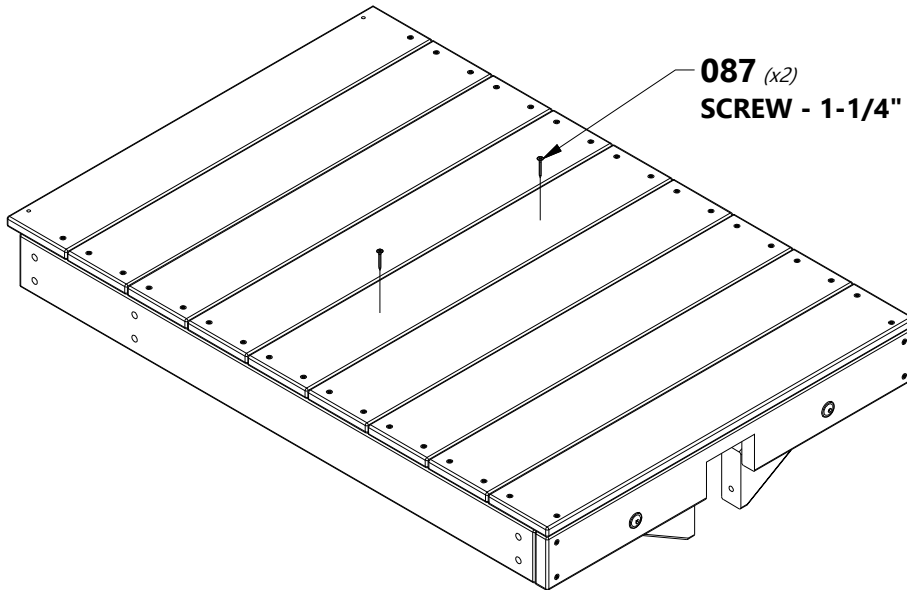

**H100087 | SCREW PFH**  
(2) | 8x1 1/4



**MARK LOCATIONS SHOWN.  USING AN 3/16\"**

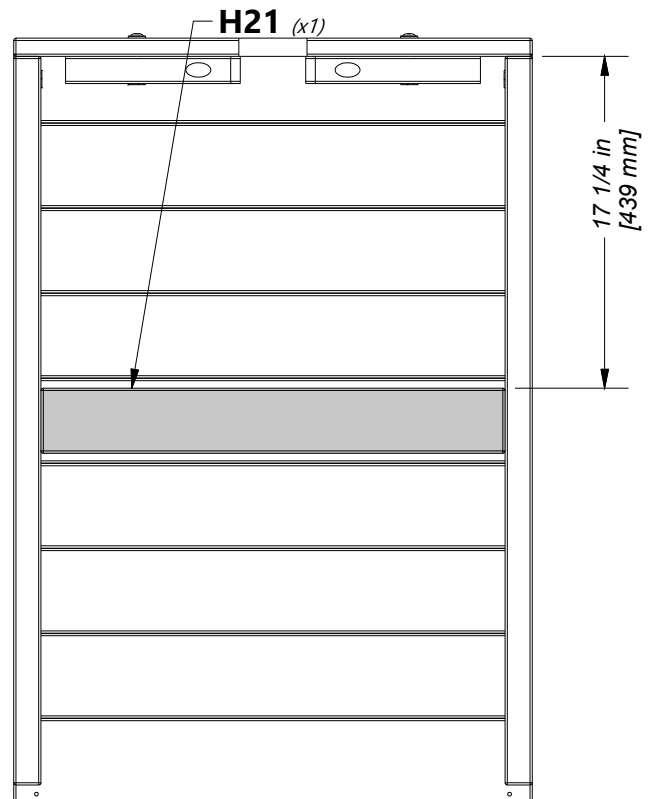



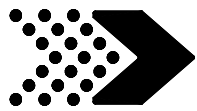

# MONKEY BAR ASSEMBLY

## STEP 1

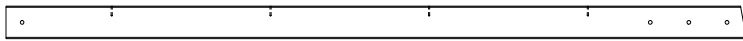

**E4** | MONKEY BAR RAIL - W4L15936  
(x2) | 1 3/8"x3 3/8"x77 1/8" (36x86x1959)

**A100045** | METAL RUNG 559 GREEN  
(x4)



**A100294** | TRIANGLE  
(x2) | PLATE 100° 5  
HOLE



**A4M01046** | L BRACKET  
(x4) | 2.5x38x55x55

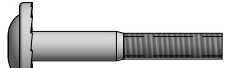

**H100012** | BOLT WH  
(x2) | 5/16x2

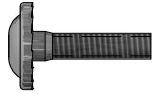

**H100009** | BOLT WH  
(x6) | 5/16x1 1/4



**H100145** | LAG SCREW WH  
(x8) | 1/4x1 1/2

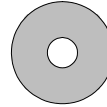

**H100105** | WASHER FLAT  
(x2) | 8x27

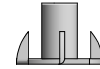

**H100074** | T-NUT  
(x6) | 5/16



**H100110** | NUT LOCK  
(x2) | 5/16



**TIP:**  
SCREW TAPPING 14x1-1/2  
USE A #3 PHILLIPS BIT.



**TIP:**  
INSTALL T-NUTS INTO  
BOARDS BEFORE ASSEMBLY.

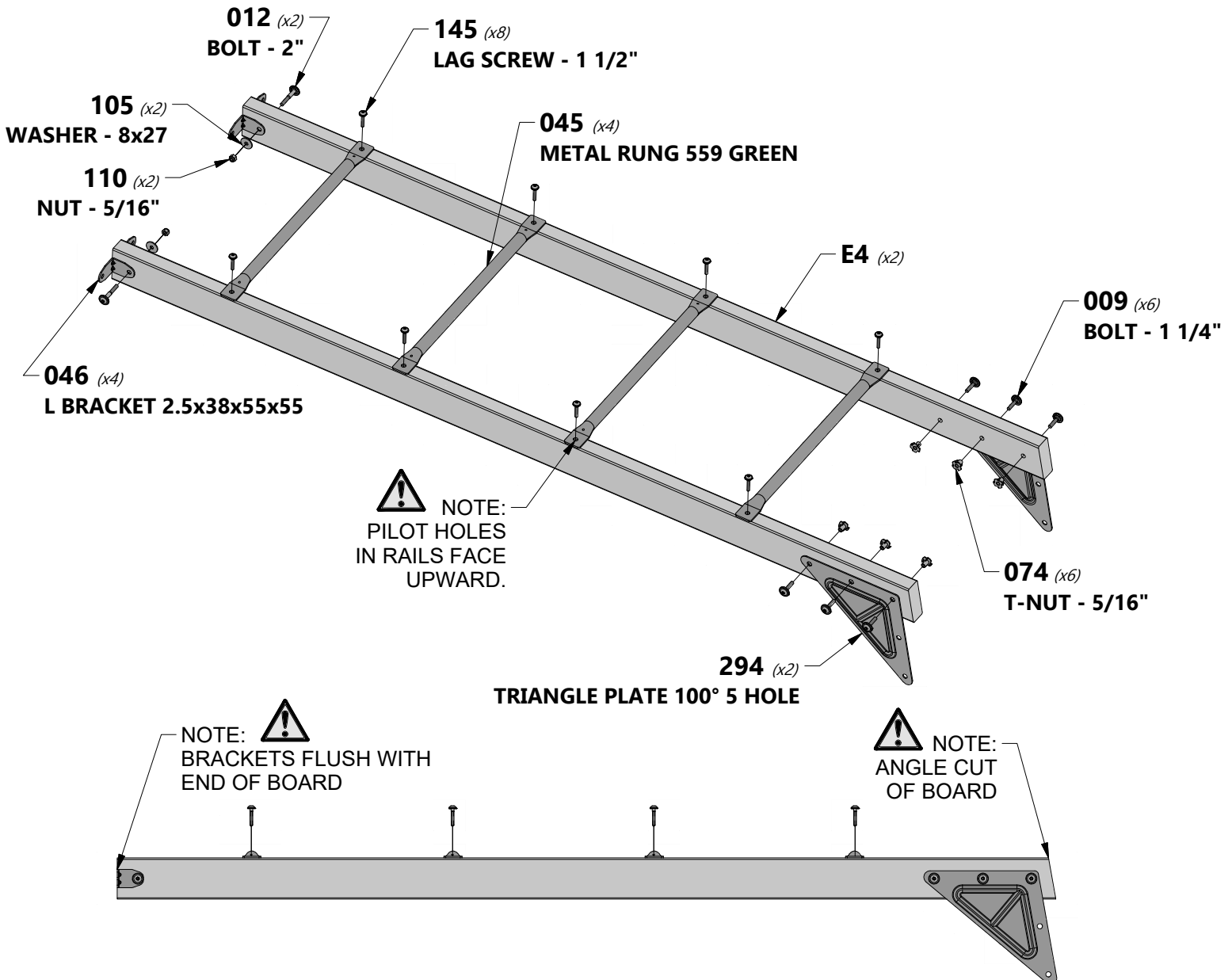

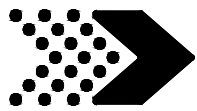

# MONKEY BAR ASSEMBLY

## STEP 2

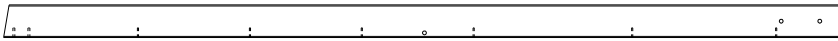

**E5** | MONKEY BAR UPRIGHT - W4L15937  
(x2) | 1 3/8"x3 3/8"x87 5/8" (36x86x2226)



**A100045** | METAL RUNG 559 GREEN  
(x4)



**A100118** | HAND GRIP METAL GREEN 381 c/c  
(x2)



**H100145** | LAG SCREW WH  
(x12) | 1/4x1 1/2

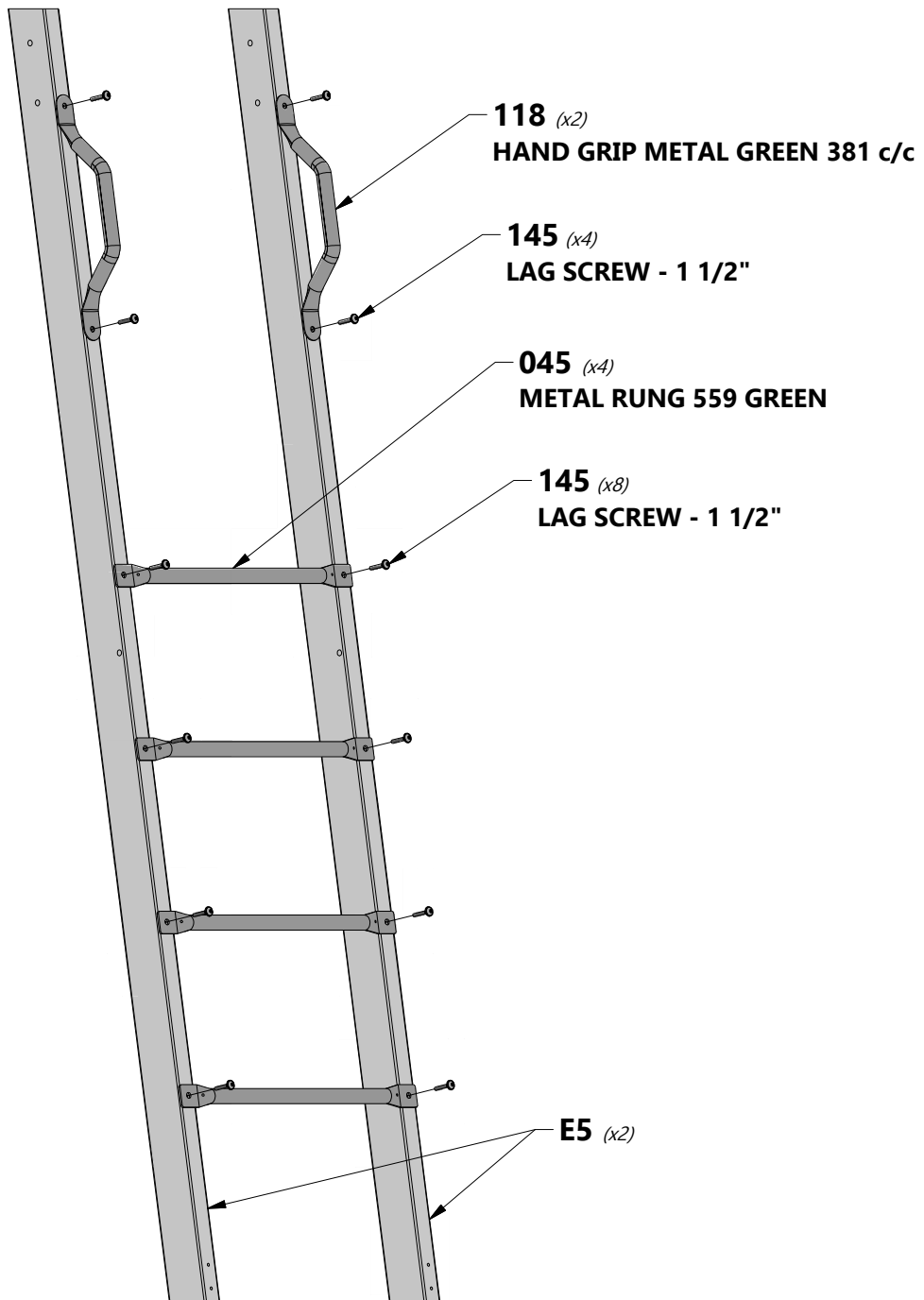

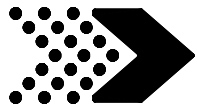

# MONKEY BAR ASSEMBLY

## STEP 3

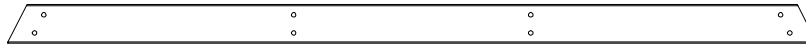

**H32 | MONKEY BAR GROUND BOARD - W4L15935**  
(x1) | 1"x3 3/8"x70 3/8" (24x86x1786)



**H22 | MONKEY BAR BRACE - W4L15934**  
(x2) | 1"x3 3/8"x51 1/2" (24x86x1308)



**H100047 | BOLT HEX**  
(x2) | 5/16x2 3/4



**H100028 | LAG SCREW WH**  
(x4) | 5/16x2 1/2

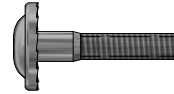

**H100010 | BOLT WH**  
(x4) | 5/16x1-1/2

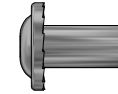

**H100005 | NUT BARREL WH**  
(x4) | 5/16x7/8



**H100074 | T-NUT**  
(x2) | 5/16



**H100031 | WASHER LOCK EXT**  
(x4) | 12x19



**H100030 | WASHER LOCK EXT**  
(x8) | 8x19



**H100106 | WASHER FLAT**  
(x2) | 9x18



**H100108 | WASHER LOCK INT**  
(x2) | 8x15



**TIP:**  
INSTALL T-NUTS INTO  
BOARDS BEFORE ASSEMBLY.

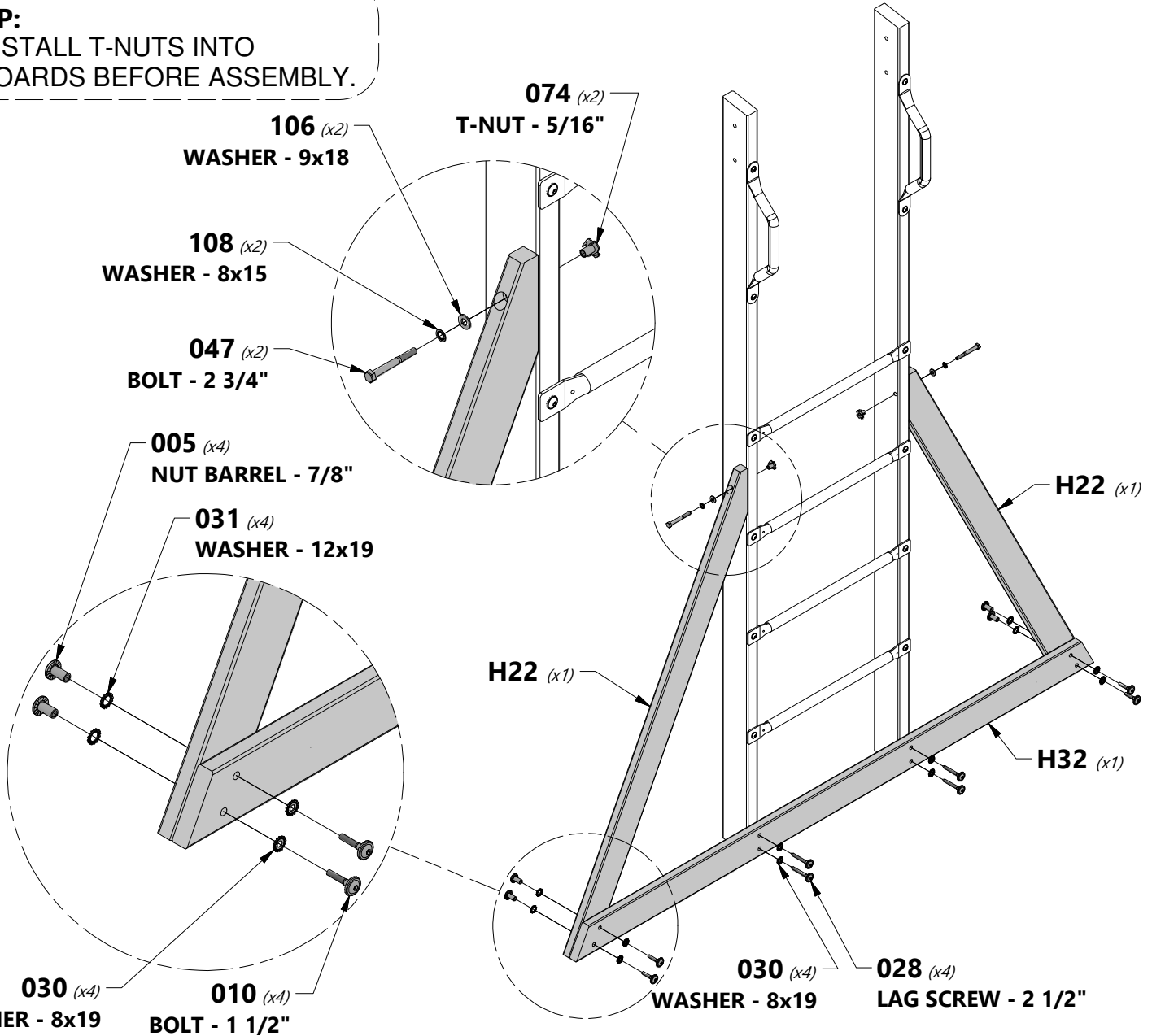

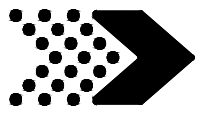

# MONKEY BAR ASSEMBLY

## STEP 4

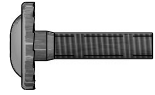

**H100009** | BOLT WH  
(x4) | 5/16x1 1/4



**H100074** | T-NUT  
(x4) | 5/16

 **TIP:**  
INSTALL T-NUTS INTO BOARDS  
BEFORE ASSEMBLY

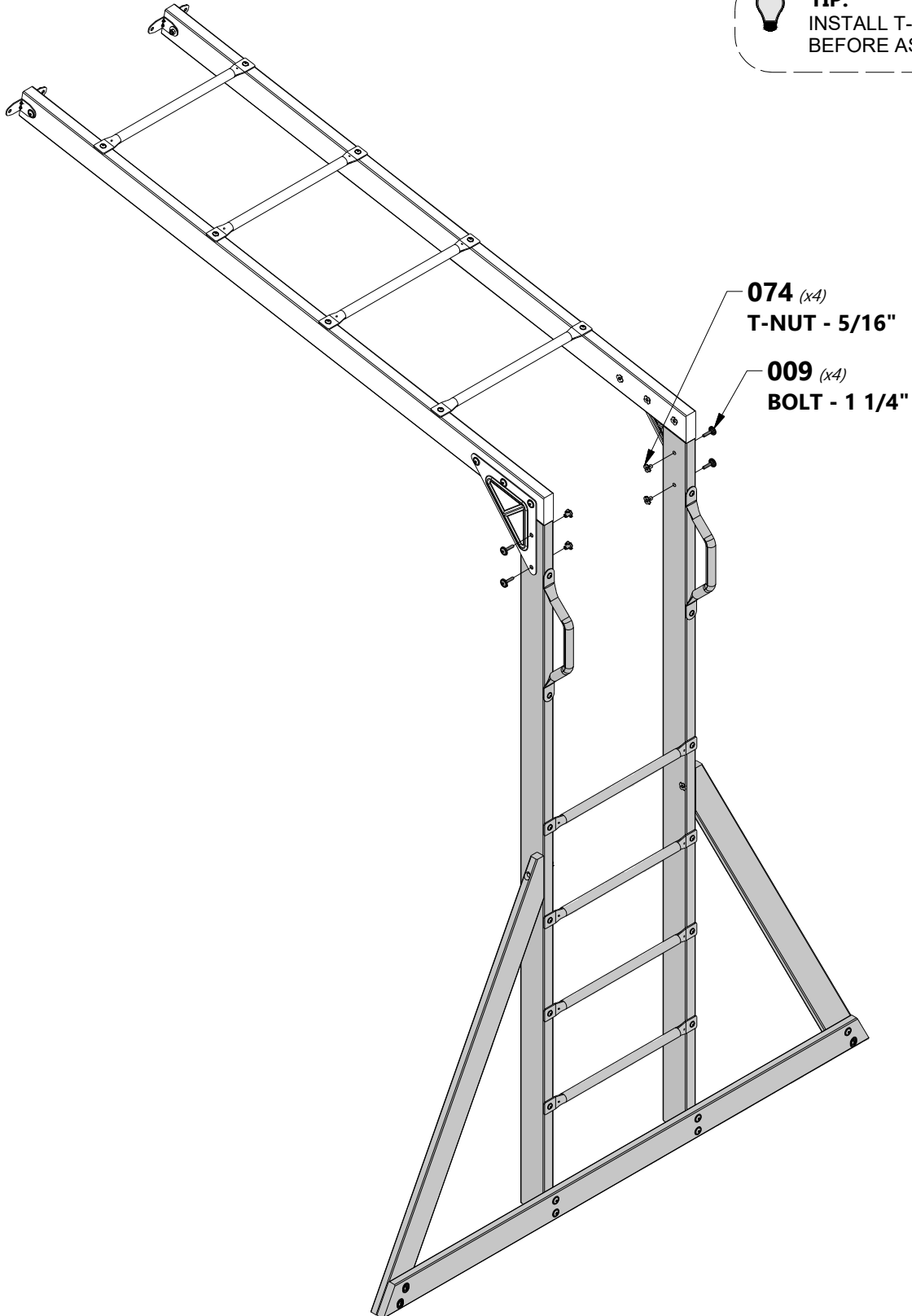



# SLIDE ASSEMBLY

# STEP 1



**A100035** | SLIDE BED 10' LIGHT GREEN  
(x1)

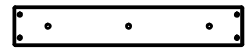

**M70** | SLIDE SUPPORT BOARD - W100935  
(x1) | 5/8"x3 3/8"x19 7/8" (16x86x505)



**H100074** | T-NUT  
(x3) | 5/16"



**H100115** | BOLT WH  
(x3) | 5/16x1/2"



**NOTE:**

TAKE NOTE OF SLIDE BED SURFACE FINISH, THE DULL SIDE WILL BE TOWARDS THE GROUND. PLACE SLIDE BRACE CENTERED ON THE BOTTOM (DULL SIDE) AND 1/2" FROM THE EDGE. USE **M70** BOARD AS A TEMPLATE FOR DRILLING BOTTOM HOLE PATTERN IN SLIDE BED. USE A 5/16" DRILL BIT.



**TIP:**

PRE-BENDING THE ENDS WILL EASE ASSEMBLY. PLACING THE SLIDE BED OUT IN THE SUN MAKES IT EASIER TO BEND.

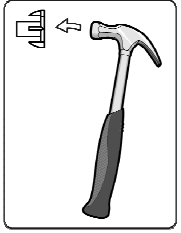

TOP

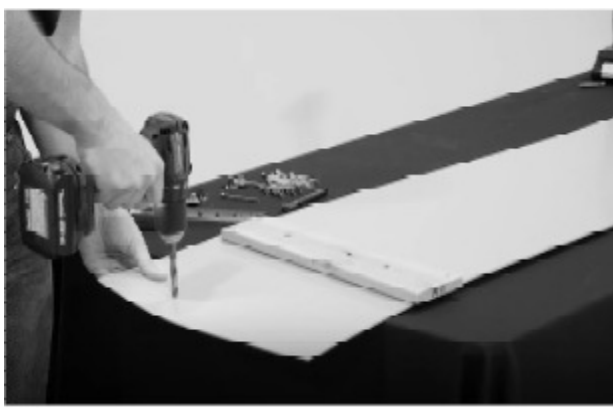
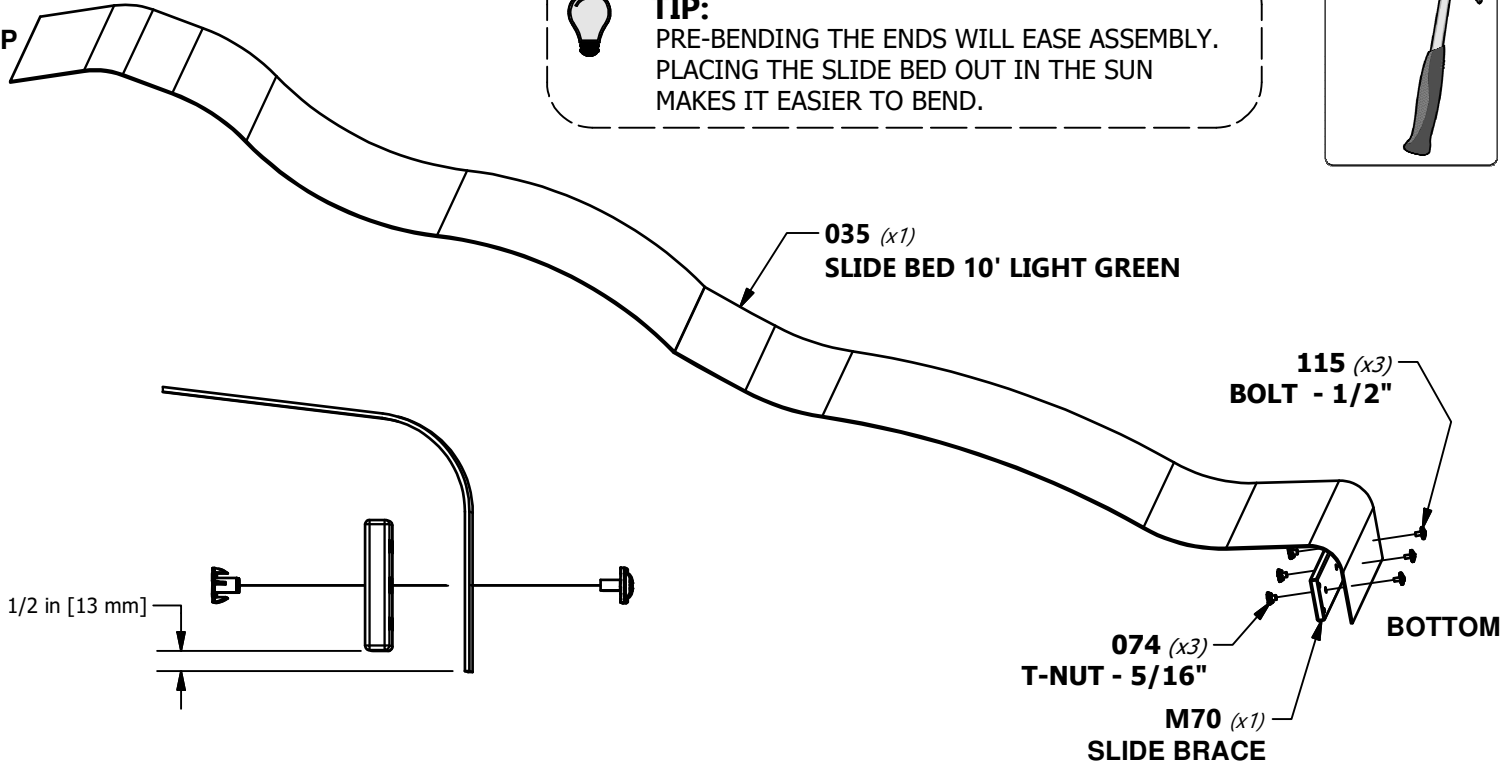



# SLIDE ASSEMBLY

## STEP 2



A6P00484 | SLIDE RAIL 10' BOTTOM RIGHT GREEN  
(x1)



A6P00486 | SLIDE RAIL 10' TOP RIGHT GREEN  
(x1)



A6P00483 | SLIDE RAIL 10' BOTTOM LEFT GREEN  
(x1)



A6P00485 | SLIDE RAIL 10' TOP LEFT GREEN  
(x1)



H100115 | BOLT WH  
(x8) 5/16x1/2

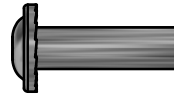

H100006 | NUT BARREL WH  
(x8) 5/16x1 1/2



**NOTE:**  
REPEAT ON OTHER SIDE, MAKING  
A LEFT AND RIGHT ASSEMBLY.

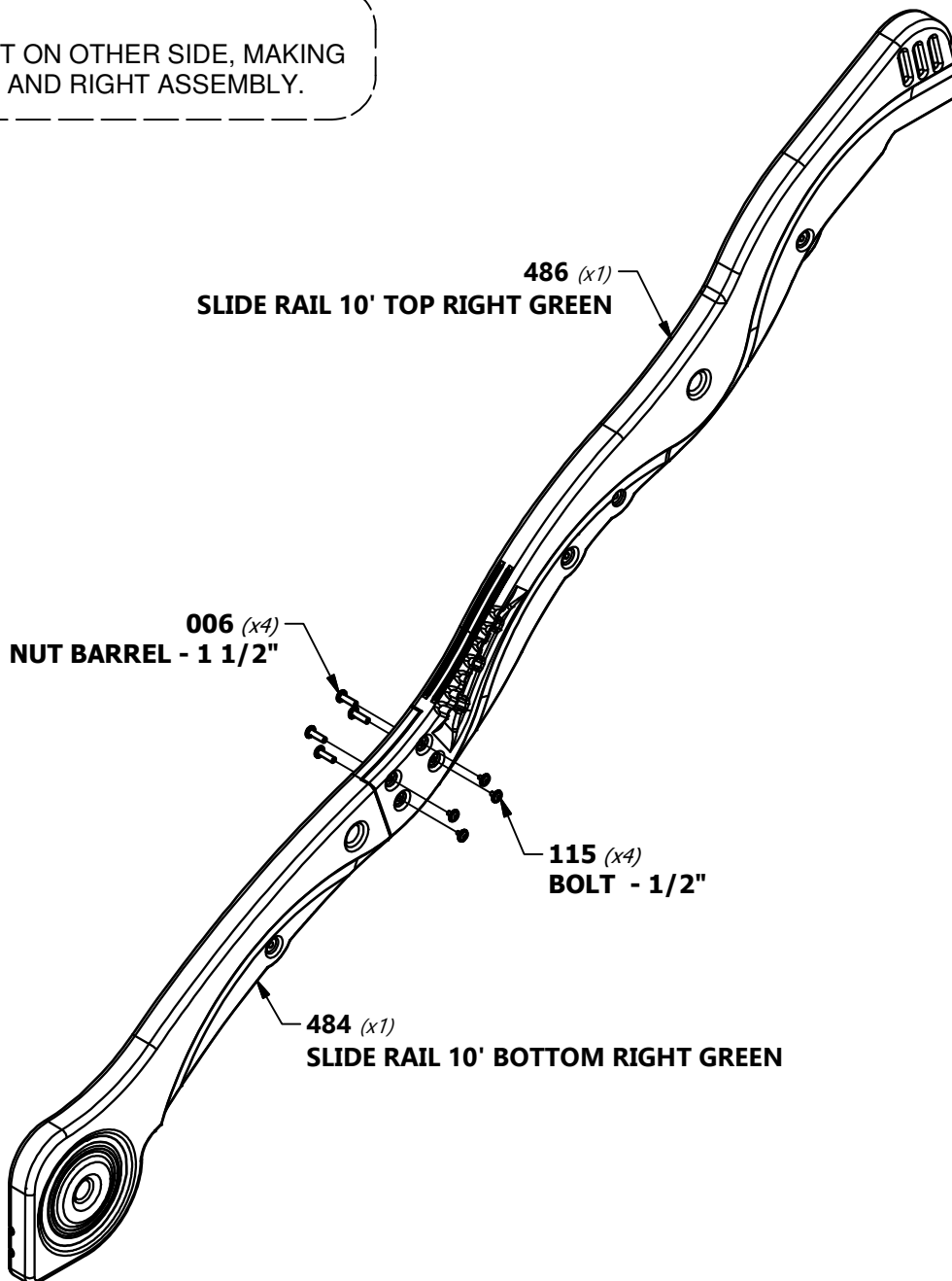

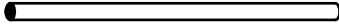

  
**A6P00487** | SLIDE TUBE SUPPORT  
 (x4)

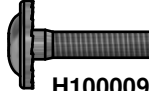
  
**H100009** | BOLT WH  
 (x4) | 5/16x1 1/4

**NOTE:**

INSERT THE (4) SLIDE SUPPORT TUBES INTO THEIR RESPECTIVE PILOT LOCATIONS (FIGURE 1).

PLACE (1) SLIDE RAIL ASSEMBLY ON A FLAT SURFACE AND BEGIN INSERTING SLIDE BED AT THE BOTTOM OF THE SLIDE RAIL (FIGURE 2). HAVE A HELPER BEND THE SLIDE BED TOWARDS THE TOP OF THE SLIDE AND INSERT THE BED INTO THE SLIDE CAVITY. MAKE SURE SLIDE BED IS INSERTED WITHIN 1/8" (3mm) OF GROOVE BOTTOM.

**TIP:**

A HELPER IS RECOMMENDED FOR THESE FOLLOWING STEPS.

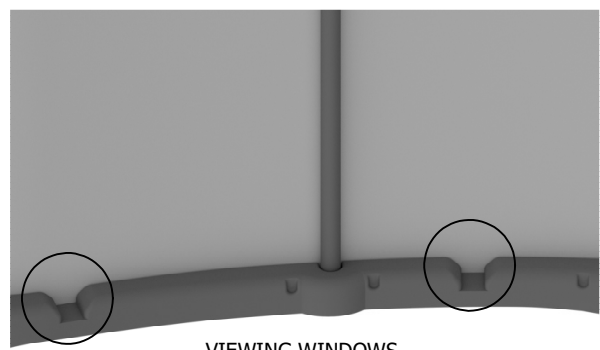
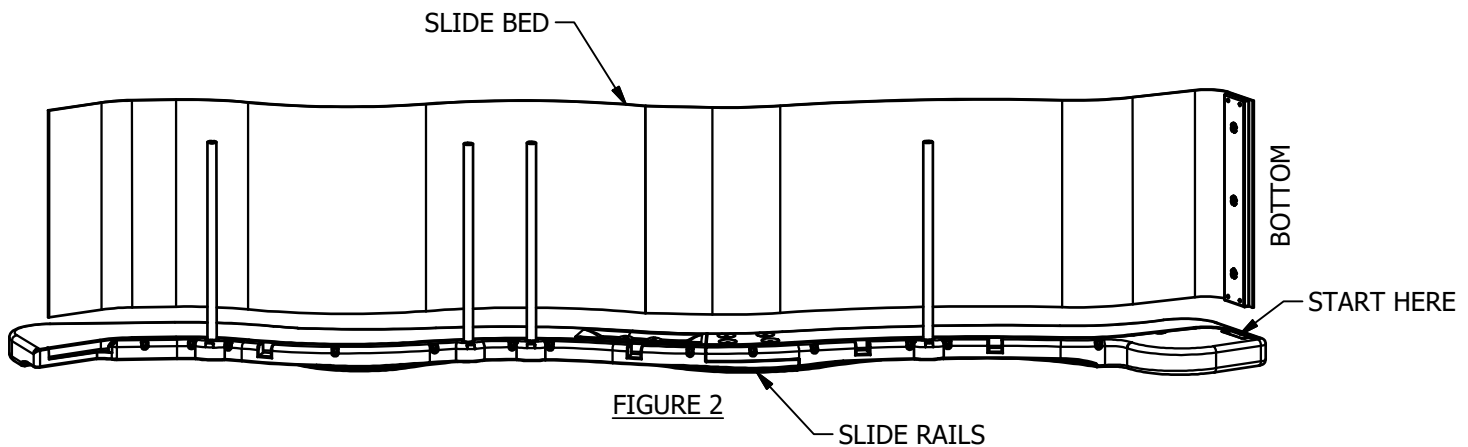
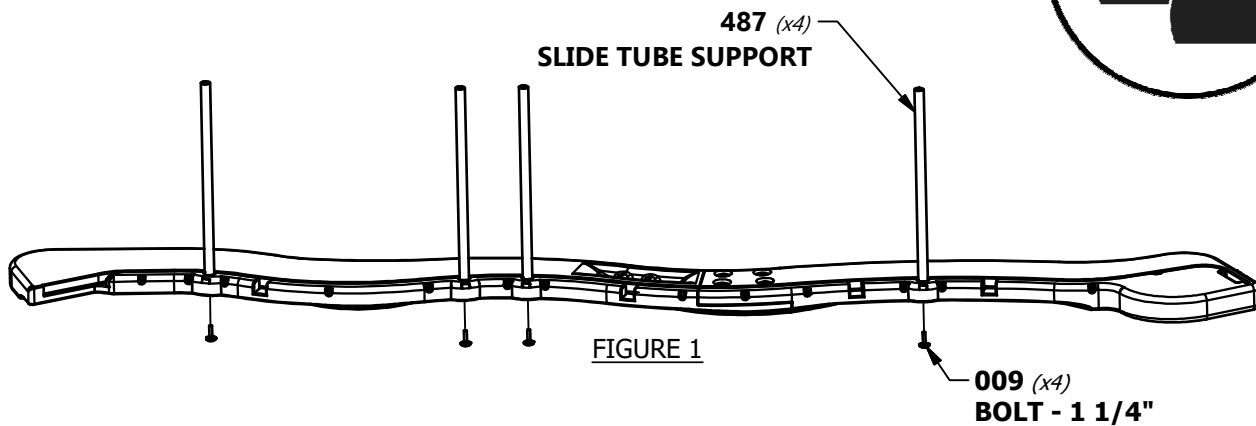



**NOTE:**

PLACE SECOND SLIDE RAIL ASSEMBLY OVER THE TOP OF THE SLIDE BED AND SLIDE SUPPORT TUBES. INSERT THE SLIDE BED AND SLIDE SUPPORT TUBES INTO THE SLIDE CAVITY. MAKE SURE SLIDE BED IS INSERTED WITHIN 1/8" (3mm) OF GROOVE BOTTOM.



**FAILURE TO INSERT SLIDE BED PROPERLY MAY RESULT IN INJURY OR AMPUTATION. EXPOSED SLIDE EDGES CAN BE SHARP AND BECOME A LACERATION HAZARD IF THE SLIDE IS NOT PROPERLY ASSEMBLED.**

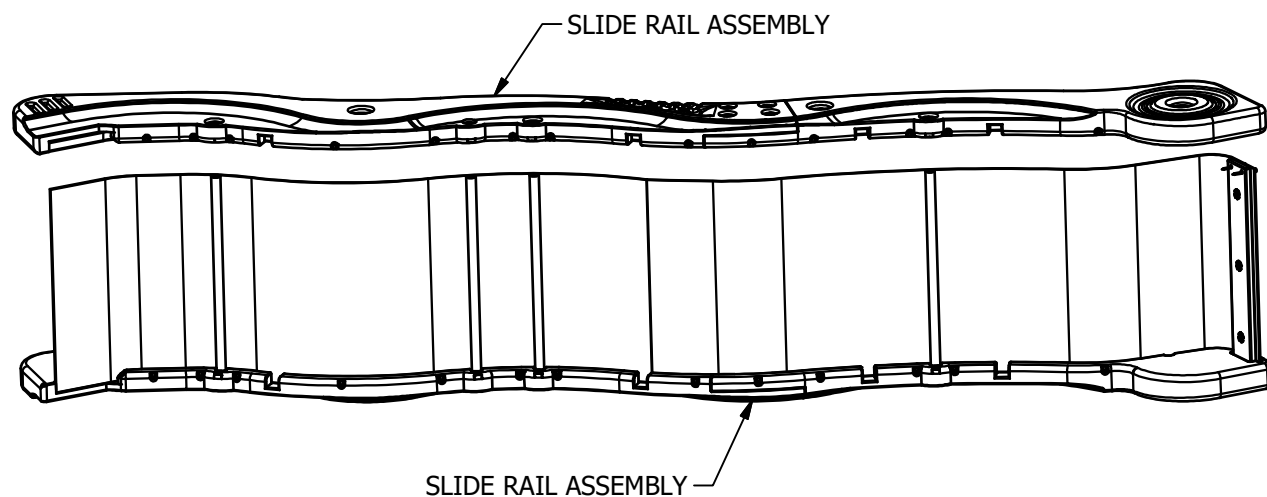

**TIP:**

USE A RUBBER Mallet TO FULLY SEAT THE SLIDE BED INTO THE SLIDE CAVITY.



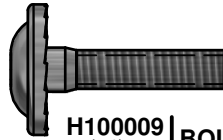

H100009 | BOLT WH 5/16x1 1/4  
(x4)



**NOTE:**  
USE 1 1/4" BOLTS TO FASTEN EACH  
SIDE OF THE SLIDE SUPPORT TUBES.



**TIP:**  
HAVING A HELPER HOLD THE SLIDE  
ASSEMBLY TOGETHER WHILE YOU FASTEN  
WILL MAKE IT EASIER TO ASSEMBLE.

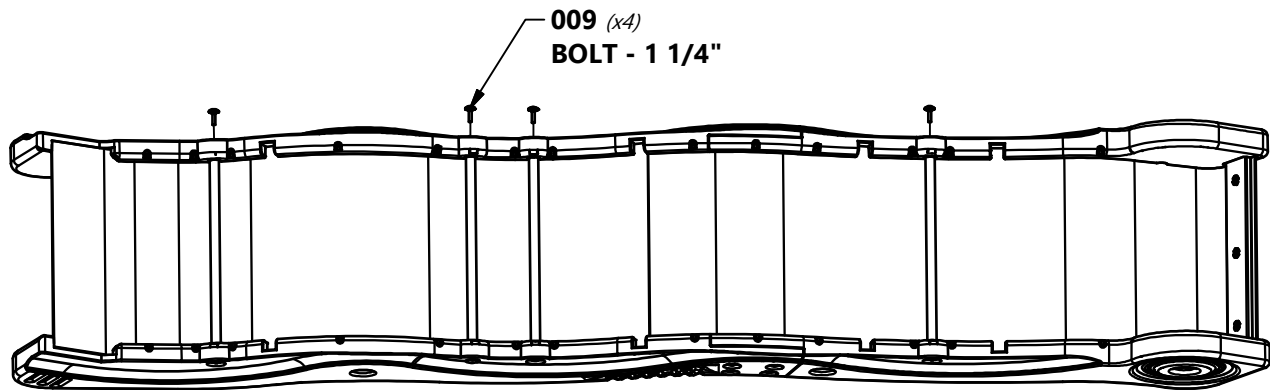
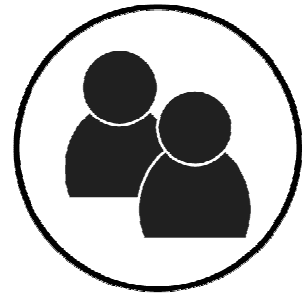



H100090 | SCREW PFH  
(x30) | 8x2 1/2"



**NOTE:**

USING AN 1/8" DRILL BIT, DRILL PILOT HOLES IN EACH INDENTATION ALONG EACH SIDE RAIL. THERE SHOULD BE 15 INDENTATIONS ON EACH RAIL. BE SURE TO DRILL THROUGH THE SLIDE RAIL AND THE SLIDE BED. THEN SECURE WITH THE PROVIDED HARDWARE.

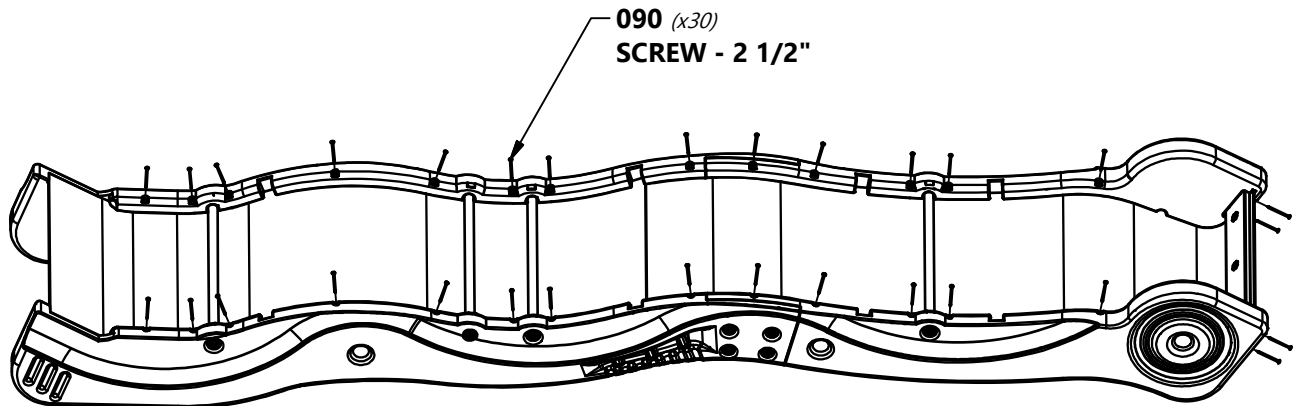

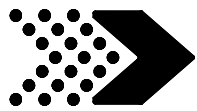

# BAY WINDOW ASSEMBLY

## STEP 1



**H100086 | SCREW PFH**  
(40) | 8x1 1/2



**H100085 | SCREW PFH**  
(8) | 8x1

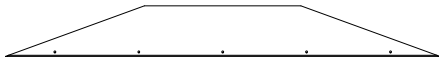

**G5 | BAY WINDOW HEADER - W4L04659**  
(4) | 1"x5 1/4"x45 1/4" (24x134x1150)

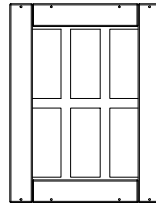

**WP1 | BAY WINDOW PANEL - W2A01496**  
(6) | 7/8"x15 3/4"x20 3/4" (21x400x526)

**MAKE 2 WINDOW ASSEMBLIES.**

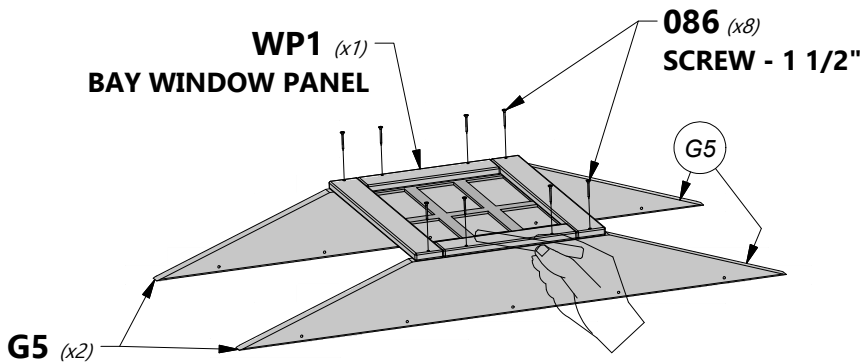

**NOTE:**  
MARK CENTERS ON EACH PART  
THEN ALIGN PARTS ON MARKS.

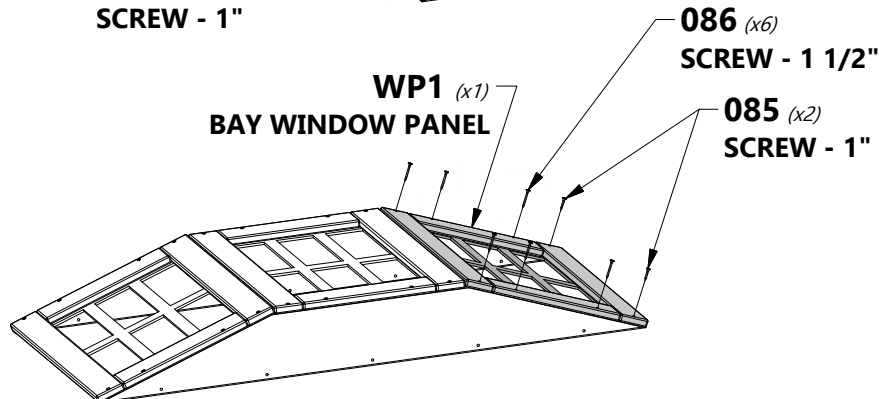
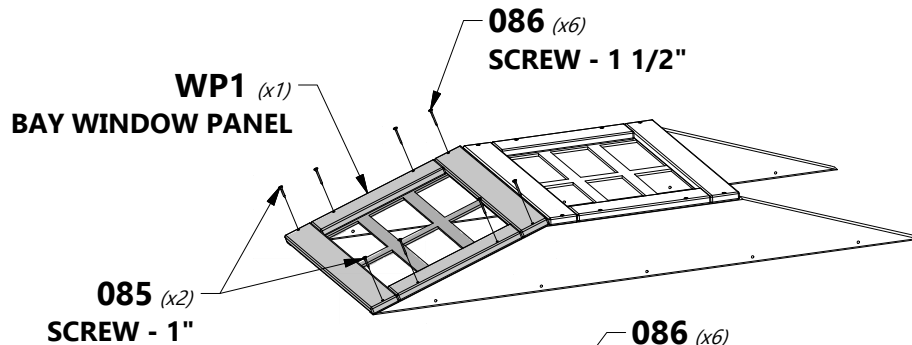



# SWING BEAM

# STEP 1

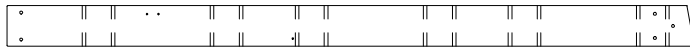

**A1** | SWING BEAM - W4L15890  
(1) | 3 3/8"x5 1/4"x89 1/2" (86x134x2274)

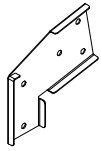

**A100325** | SWING BEAM  
(1) | EXTENSION  
BRACKET-LEFT



**A100140** | L BRACKET  
(2) | 66x66x127

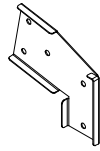

**A100326** | SWING BEAM  
(1) | EXTENSION  
BRACKET-RIGHT



**H100054** | BOLT HEX  
(2) | 5/16x4 1/4



**H100110** | NUT LOCK  
(2) | 5/16



**H100105** | WASHER FLAT  
(4) | 8x27

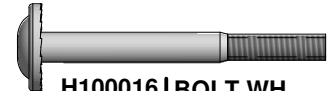

**H100016** | BOLT WH  
(3) | 5/16x3

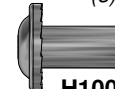

**H100005** | NUT BARREL WH  
(3) | 5/16x7/8



NOTE THIS  
EDGE UPWARD

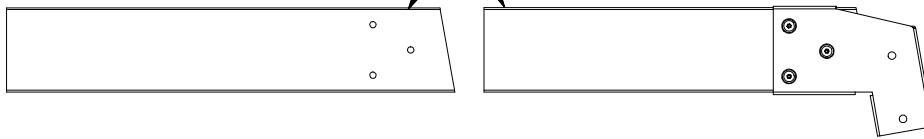

**140** (x2)  
L BRACKET 66x66x127

**110** (x2)  
NUT - 5/16"

**105** (x2)  
WASHER - 8x27

**105** (x2)  
WASHER - 8x27

**054** (x2)  
BOLT - 4 1/4"

**A1** (x1)

**005** (x3)  
NUT BARREL - 7/8"

**016** (x3)  
BOLT - 3"



DO NOT TIGHTEN BRACKET  
HARDWARE AT THIS TIME

**325** (x1)

SWING BEAM EXTENSION BRACKET-LEFT

**326** (x1)

SWING BEAM EXTENSION BRACKET-RIGHT

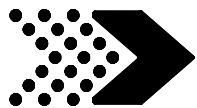

# SWING BEAM

# STEP 2



**H100654** | BOLT HEX  
(12) | 3/8x5-1/2



**H100107** | WASHER LOCK  
(12) | INT  
10x18

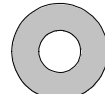

**H100102** | WASHER FLAT  
(12) | 11x25

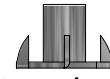

**H100073** | T-NUT  
(12) | 3/8

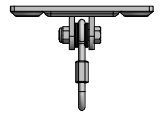

**A4M00505** | SWING HANGER  
(6)



**TIP:**  
INSTALL T-NUTS INTO  
BOARDS BEFORE ASSEMBLY.

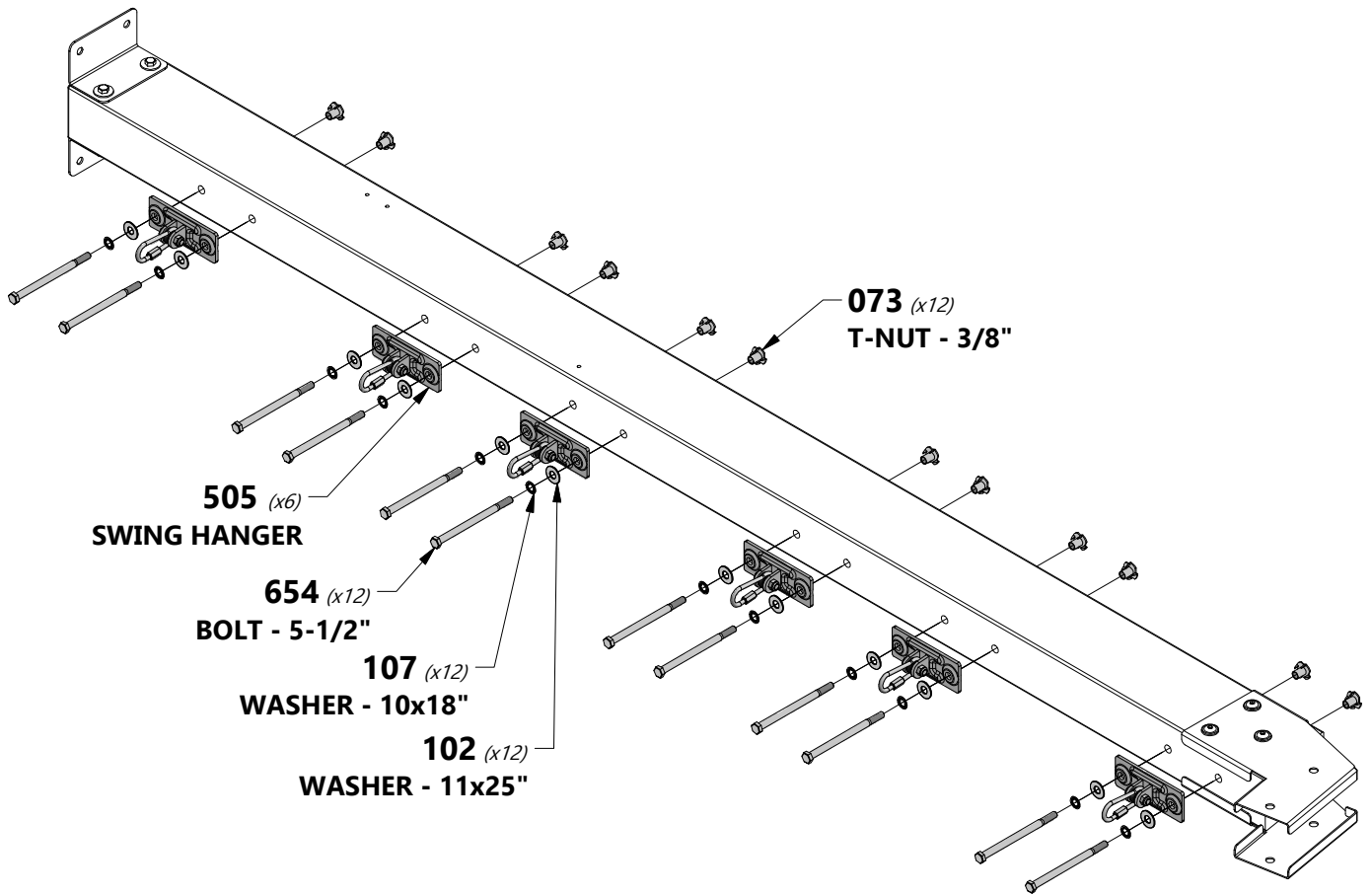

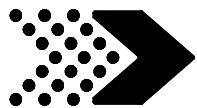

# SWING BEAM

# STEP 3

**SP1** | SWING BEAM SUPPORT - W4L15891  
 (1) | 3 3/8"x3 3/8"x48 3/8" (86x86x1229)

**E50** | END SUPPORT - W4L15893  
 (1) | 1 3/8"x3 3/8"x44 1/8" (36x86x1120)

**A4M01169** | A-FRAME  
 (1) | BRACKET

**H100019** | BOLT WH  
 (2) | 5/16x3 3/4

**H100005** | NUT BARREL WH  
 (2) | 5/16x7/8

**H100016** | BOLT WH  
 (2) | 5/16x3

**H100006** | NUT BARREL WH  
 (2) | 5/16x1 1/2

**H100031** | WASHER LOCK  
 (4) | EXT  
 12x19

**H100030** | WASHER LOCK  
 (2) | EXT  
 8x19

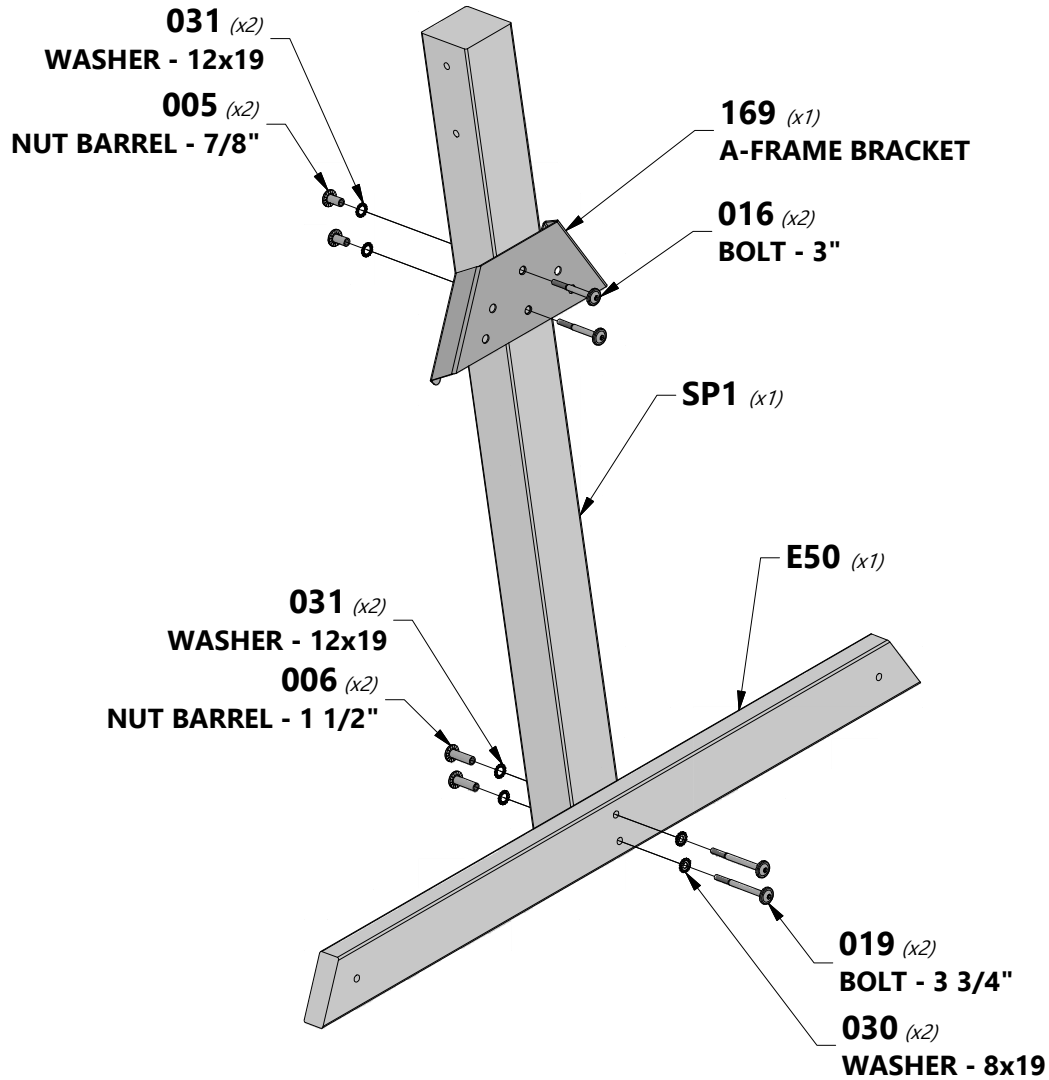

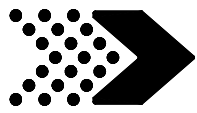

# SWING BEAM

# STEP 4

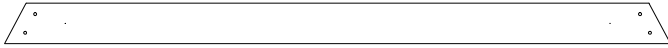

**G08** | GROUND BOARD - W4L15894  
(1) | 1"x5 1/4"x86 3/4" (24x134x2202)

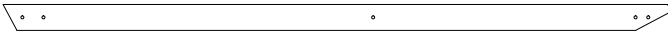

**E7** | ANGLE BRACE - W4L15892  
(2) | 1 3/8"x3 3/8"x87 1/8" (36x86x2212)



**H100014** | BOLT WH  
(2) | 5/16x2 1/2

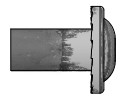

**H100005** | NUT BARREL WH  
(10) | 5/16x7/8



**H100012** | BOLT WH  
(4) | 5/16x2

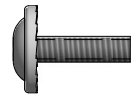

**H100008** | BOLT WH  
(4) | 5/16x1



**H100031** | WASHER LOCK  
(10) | EXT  
12x19



**H100030** | WASHER LOCK  
(6) | EXT  
8x19

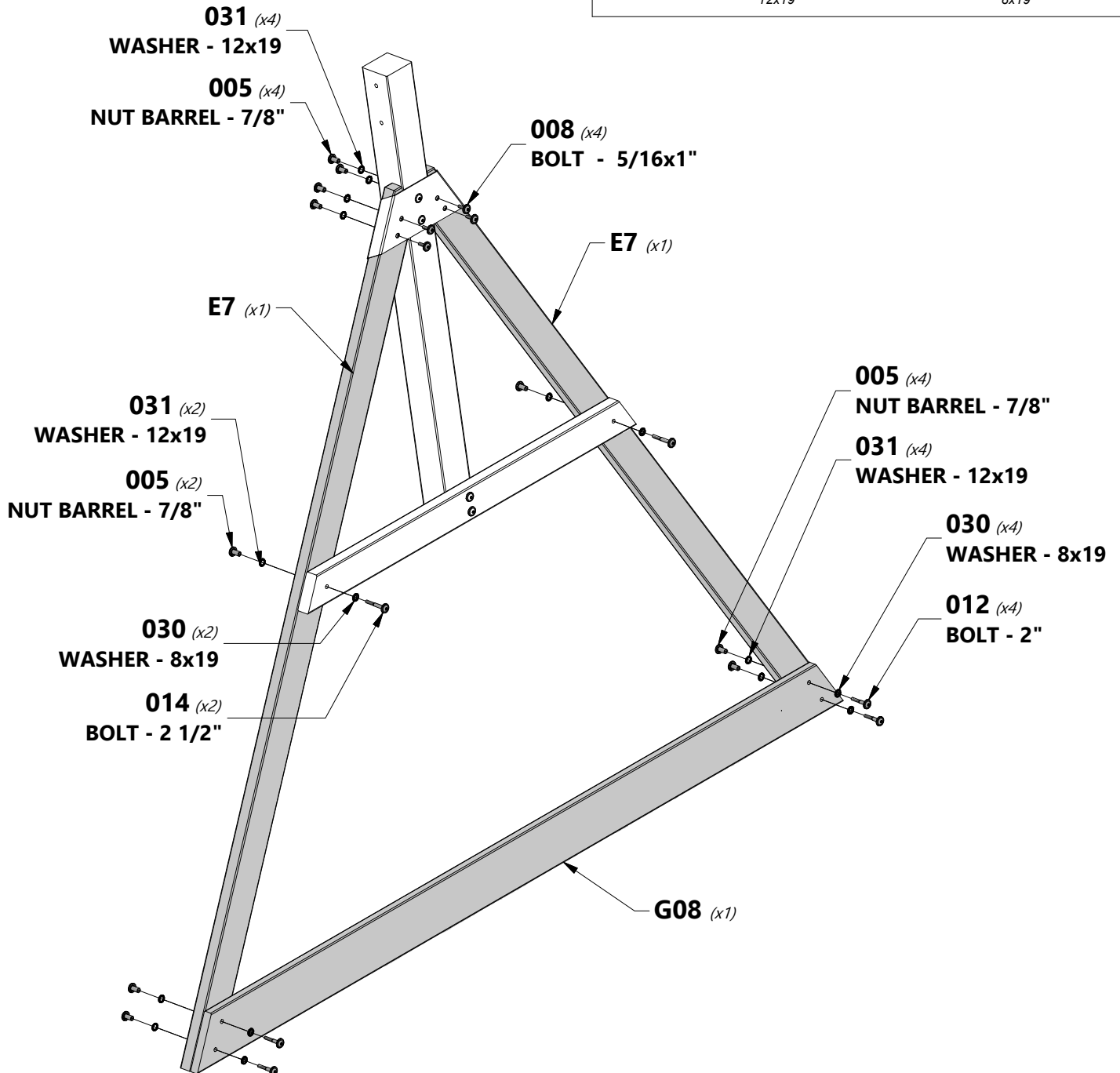

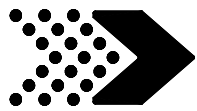

# SWING BEAM

## STEP 5

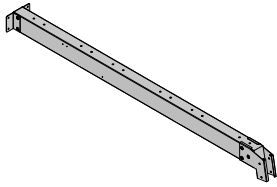

(1) BEAM ASSEMBLY

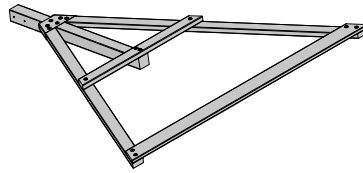

(1) END ASSEMBLY

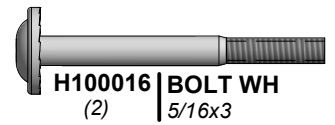

**H100016** | BOLT WH  
(2) | 5/16x3



**H100005** | NUT BARREL WH  
(2) | 5/16x7/8

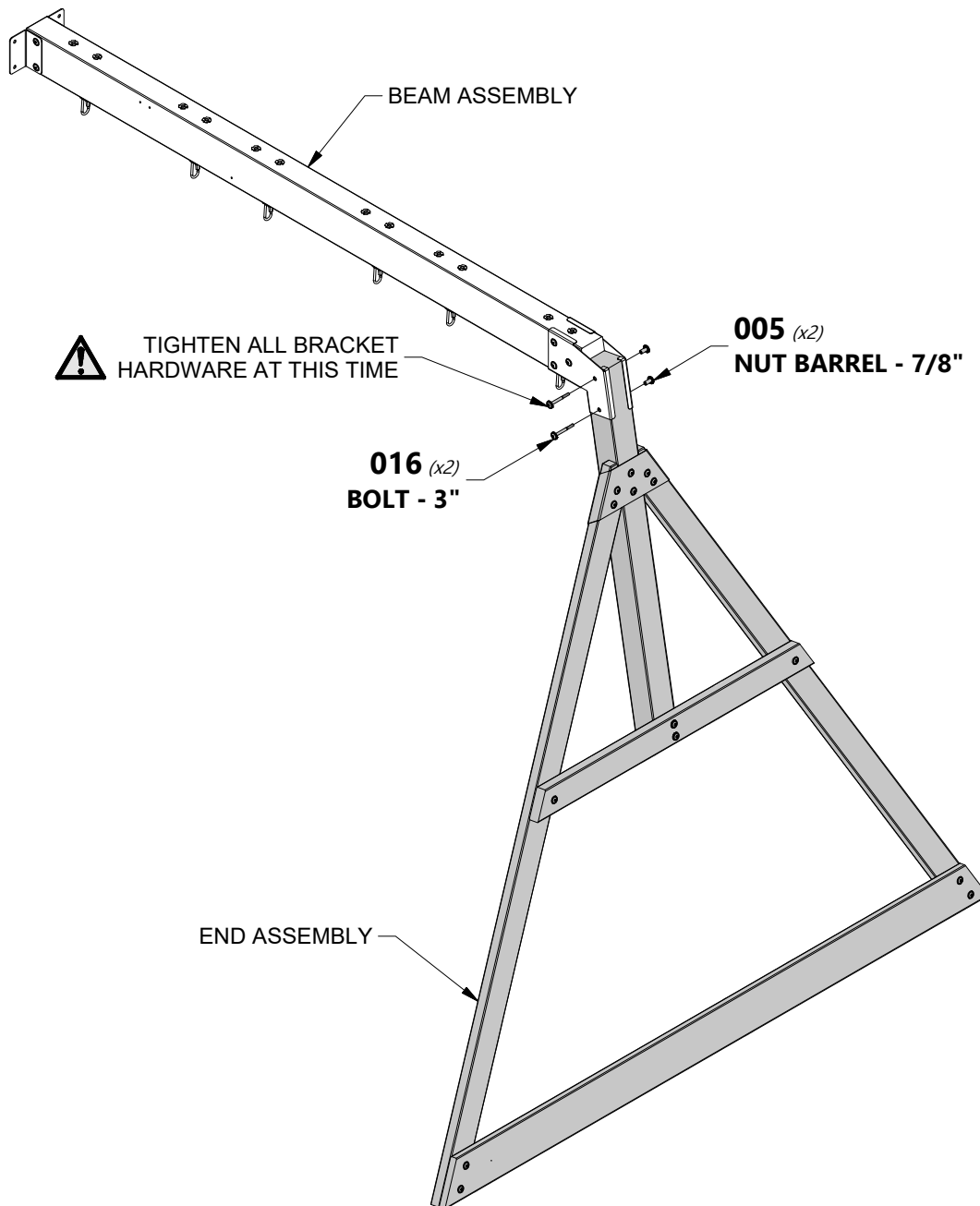



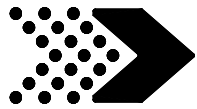

# PORCH ROOF

# STEP 1



(4) **H20 - PORCH ROOF RAFTER - W4L04655**  
1"x3 3/8"x24 1/2" (24x86x622)



**H100091 | SCREW PFH**  
(2) | 8X2 1/4



**NOTE:**  
USING A 3/16" DRILL BIT, MARK AND DRILL A PILOT HOLE INTO 'H20' RAFTER TO PREVENT SPLITTING.  
ONLY DRILL THROUGH ONE RAFTER NOT BOTH.

1 1/4 in [32 mm]      1/2 in [12 mm]

**091 (x2)**  
**SCREW - 2 1/4"**

**H20 (x4)**

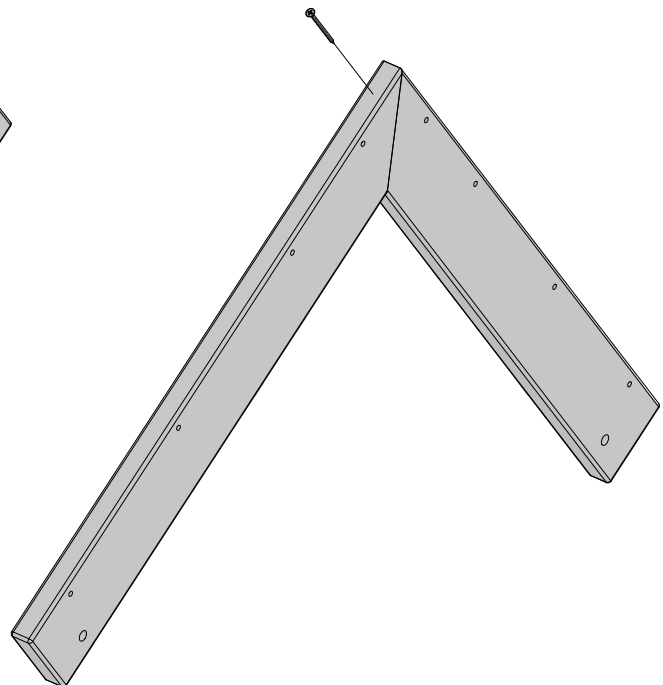
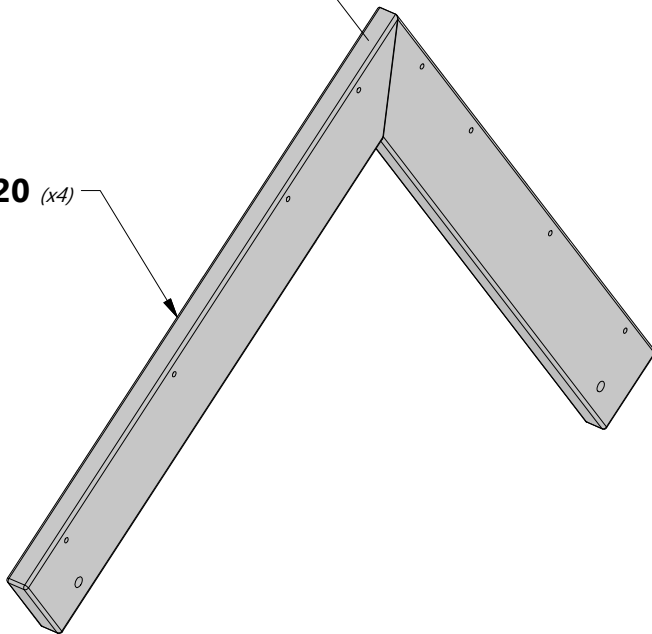

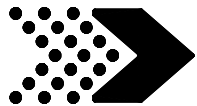

# PORCH ROOF

# STEP 2

**M19** FRONT PORCH ROOF SUPPORT - W4L04658  
 (1) 5/8"x3 3/8"x30 5/8" (16x86x779)

**N8** FRONT PORCH GABLE TRIM - W4L04657  
 (2) 5/8"x2 3/8"x9 1/2" (16x60x241)

**H100088** SCREW PFH  
 (6) 8x1 1/8

**A100164** BYD ID TAG (LARGE) AGES 3-10  
 (1)

**N5** FRONT PORCH GABLE TRIM - W4L04656  
 (1) 5/8"x2 3/8"x15" (16x60x381)

**H100128** SCREW PWH  
 (4) 8x5/8

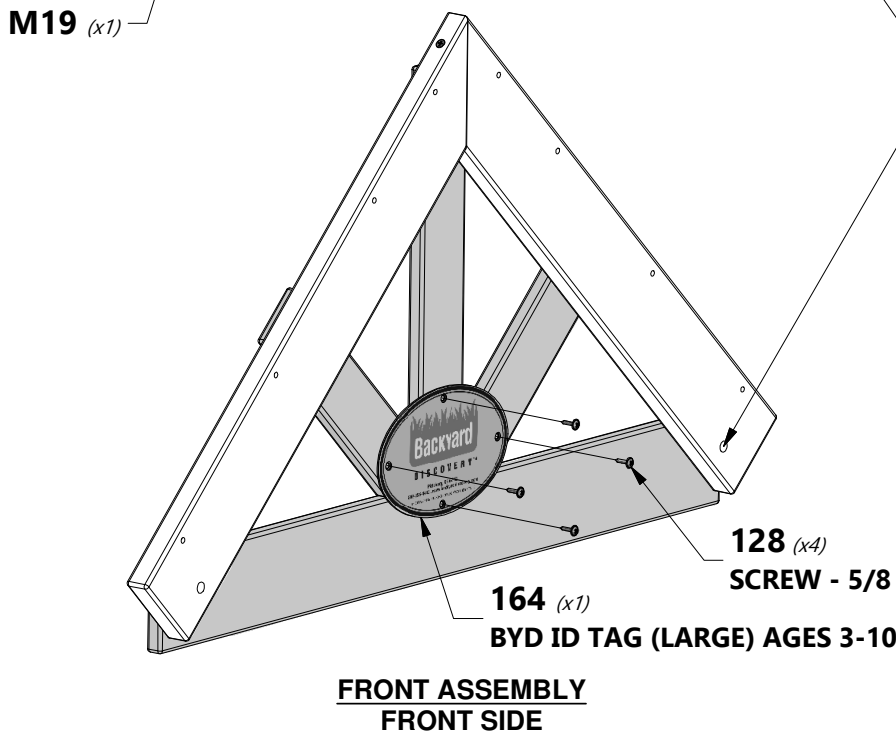
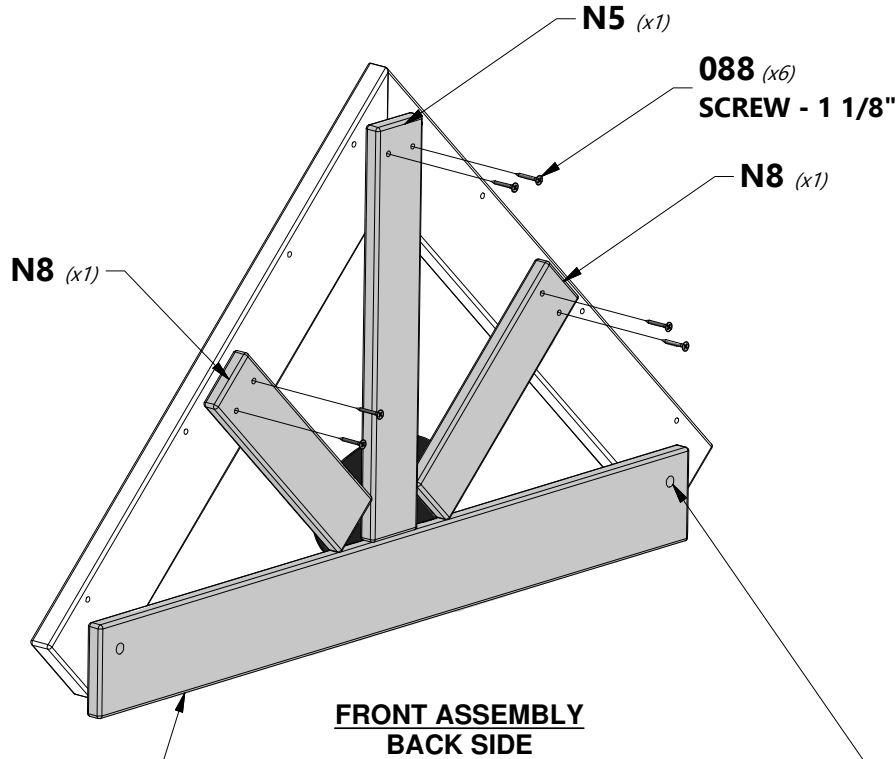

 ENSURE THAT HOLES ARE ALIGNED (BOTH ENDS)

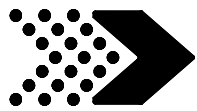

# PORCH ROOF

## STEP 3

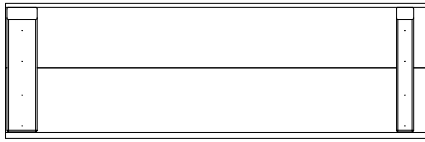

**RP1** | LEFT PORCH PEAK ROOF PANEL - W2A02630  
(1) | 1 5/8"x10 1/2"x32 7/8" (42x268x834)

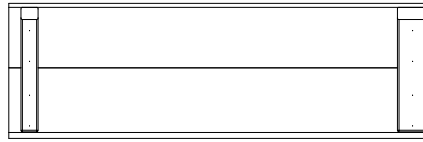

**RP4** | RIGHT PORCH PEAK ROOF PANEL - W2A02631  
(1) | 1 5/8"x10 1/2"x32 7/8" (42x268x834)



**H100111** | SCREW PFH  
(8) | 8x2

**FRONT ASSEMBLY  
BACK SIDE**

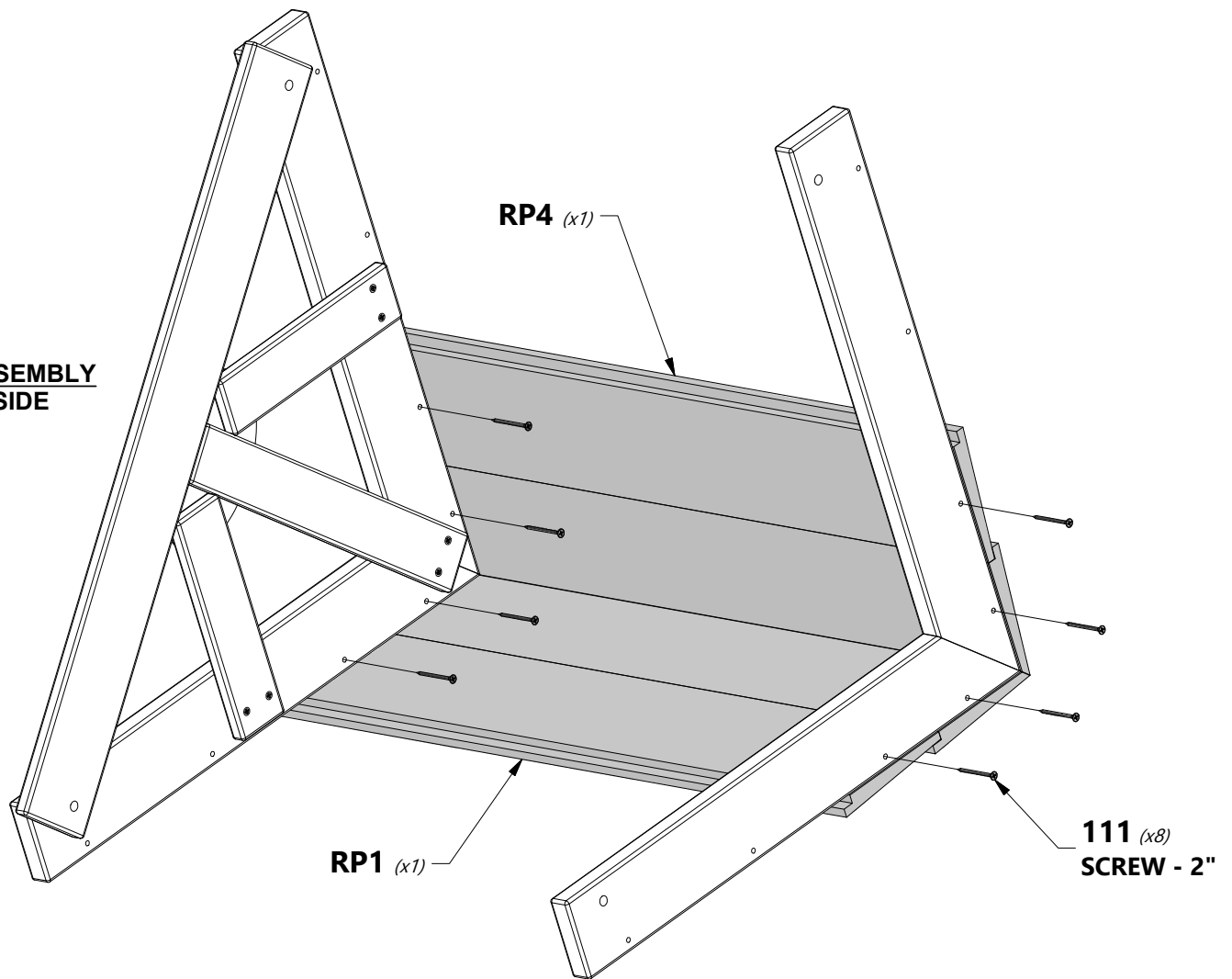

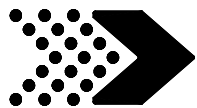

# PORCH ROOF

# STEP 4



**H100111 | SCREW PFH**  
(8) | 8x2

**RP2 | LEFT PORCH ROOF PANEL - W2A02628**  
(1) | 1 5/8"x15 5/8"x32 7/8" (42x396x834)

**RP5 | RIGHT PORCH ROOF PANEL - W2A02629**  
(1) | 1 5/8"x15 5/8"x32 7/8" (42x396x834)

**FRONT ASSEMBLY**  
**BACK SIDE**

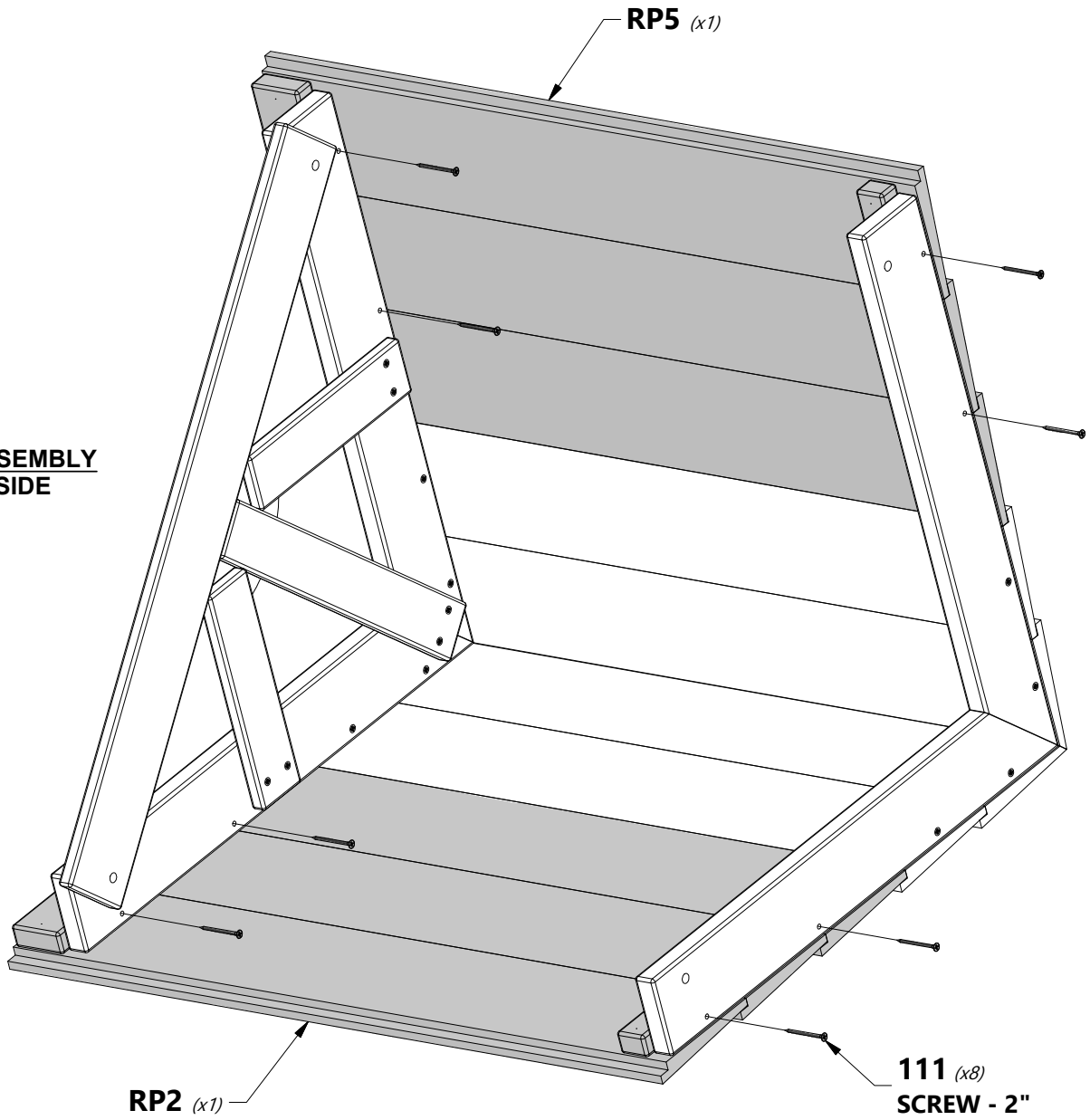

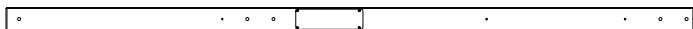
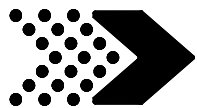

**B1** | TOWER LEG - W2A03355  
(1) | 3"x3"x89 1/2" (76x76x2274)



**E1** | TOWER LEG - W4L04563  
(1) | 1 3/8"x3 3/8"x59" (36x86x1500)



**B3** | TOWER LEG - W4L04564  
(1) | 3"x3"x59" (76x76x1500)

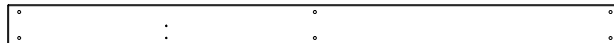

**G7** | BOTTOM FLOOR RAIL - W4L11775  
(1) | 1"x5 1/4"x80" (24x134x2032)



**G1** | TOP FLOOR RAIL - W4L04566  
(1) | 1"x5 1/4"x80" (24x134x2032)



**H100019** | BOLT WH  
(8) | 5/16x3 3/4



**H100013** | BOLT WH  
(4) | 5/16x2 1/4



**H100074** | T-NUT  
(12) | 5/16



**H100030** | WASHER LOCK  
(12) | EXT  
8x19



**TIP:**  
INSTALL T-NUTS INTO BOARDS  
BEFORE ASSEMBLY

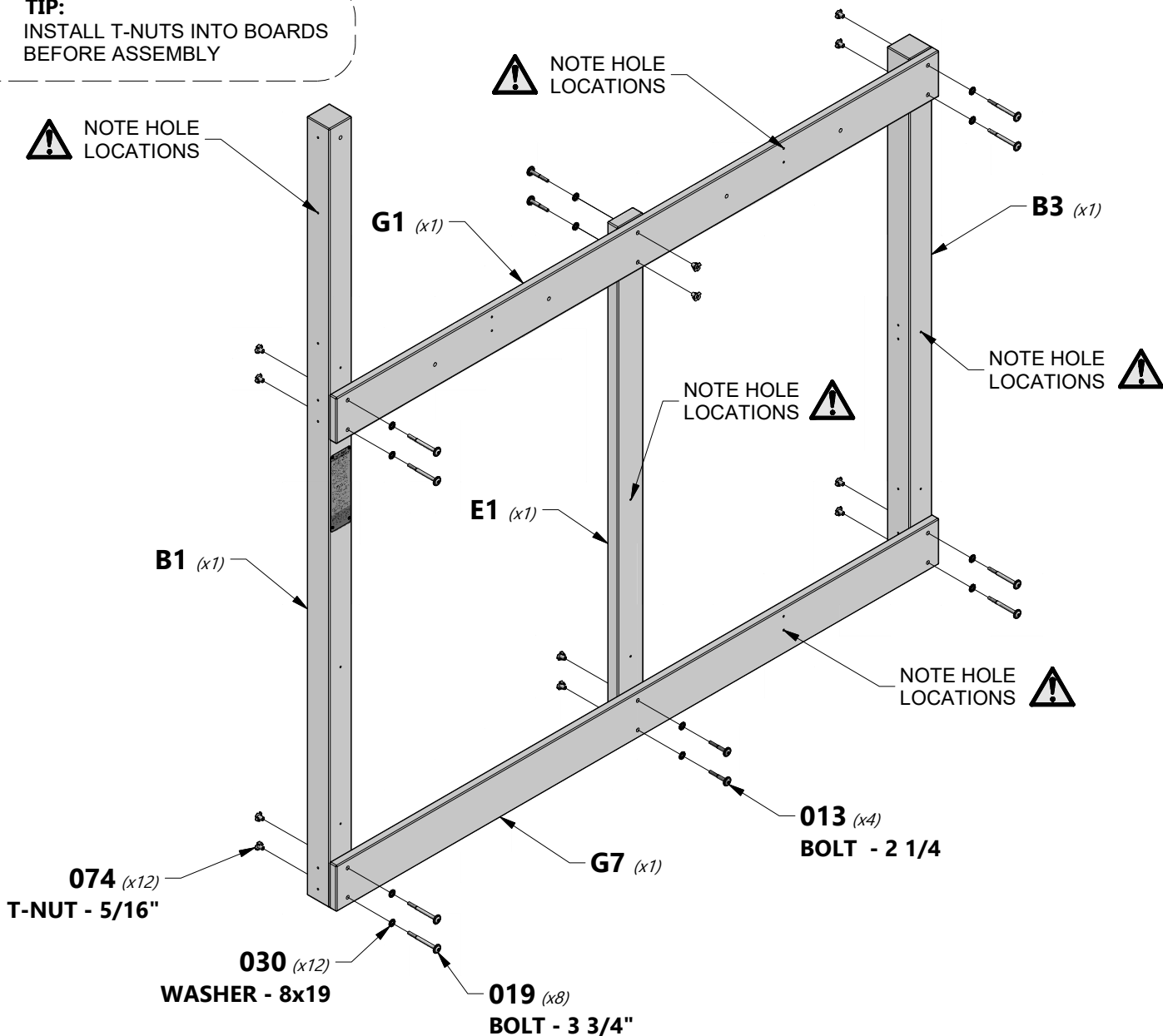



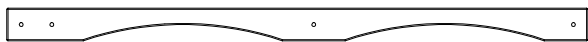

**H28** | FRONT WALL RAIL - W4L11774  
(1) | 1"x3 3/8"x60 1/2" (24x86x1537)



**G3** | FLOOR RAIL - W4L04571  
(1) | 1"x5 1/4"x60 1/2" (24x134x1537)



**G6** | FLOOR RAIL - W4L11777  
(1) | 1"x5 1/4"x60 1/2" (24x134x1537)



**H100028** | LAG SCREW WH  
(8) | 5/16x2 1/2



**H100027** | LAG SCREW WH  
(2) | 5/16x2



**H100030** | WASHER LOCK  
(10) | EXT  
8x19

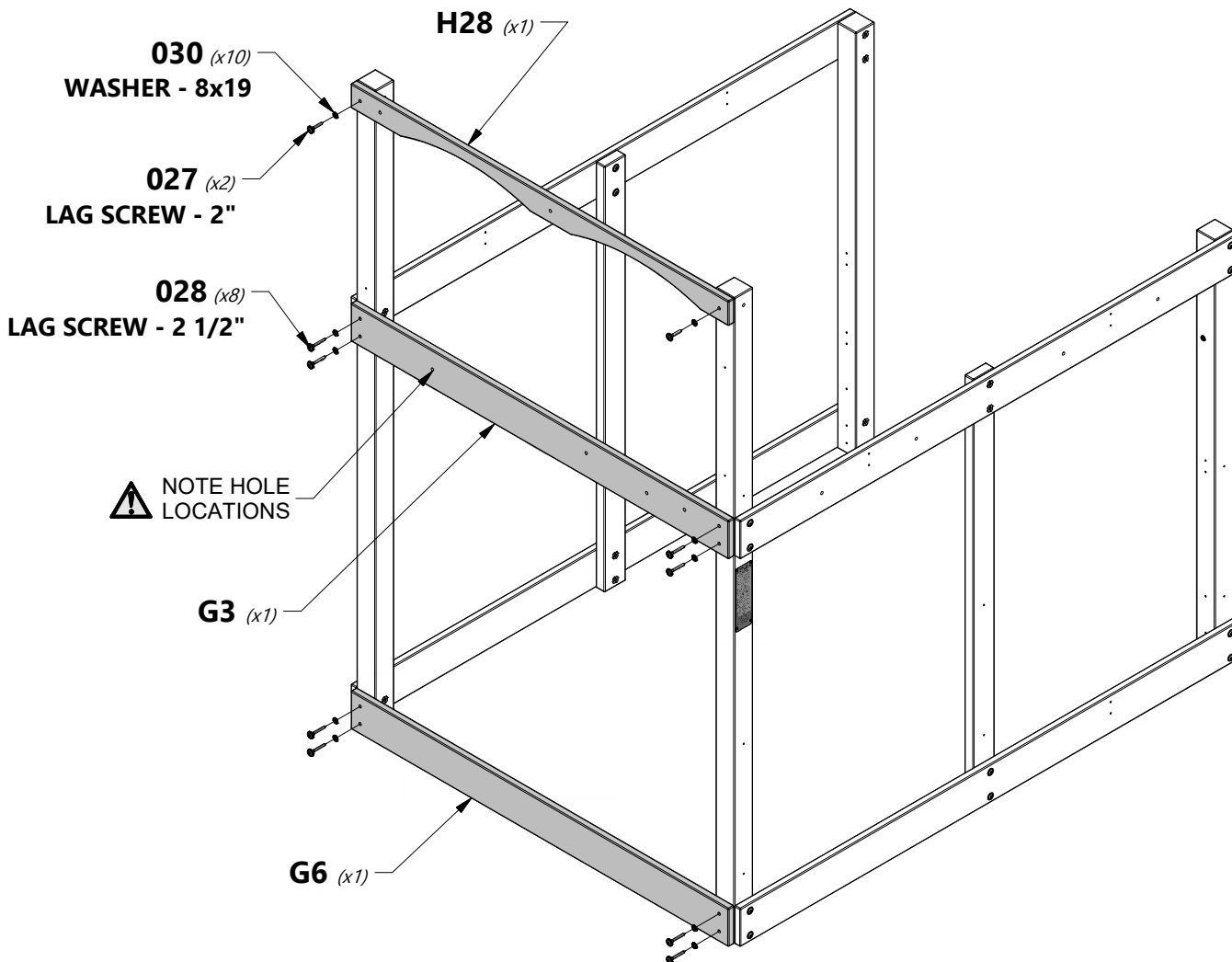



**G4** | FLOOR RAIL - W4L04675  
(1) | 1"x5 1/4"x60 1/2" (24x134x1537)



**K2** | FLOOR RAIL - W4L04570  
(1) | 5/8"x5 1/4"x60 1/2" (16x134x1537)



**H100030** | WASHER LOCK  
(8) | EXT  
8x19



**H100027** | LAG SCREW WH  
(4) | 5/16x2



**H100028** | LAG SCREW WH  
(4) | 5/16x2 1/2

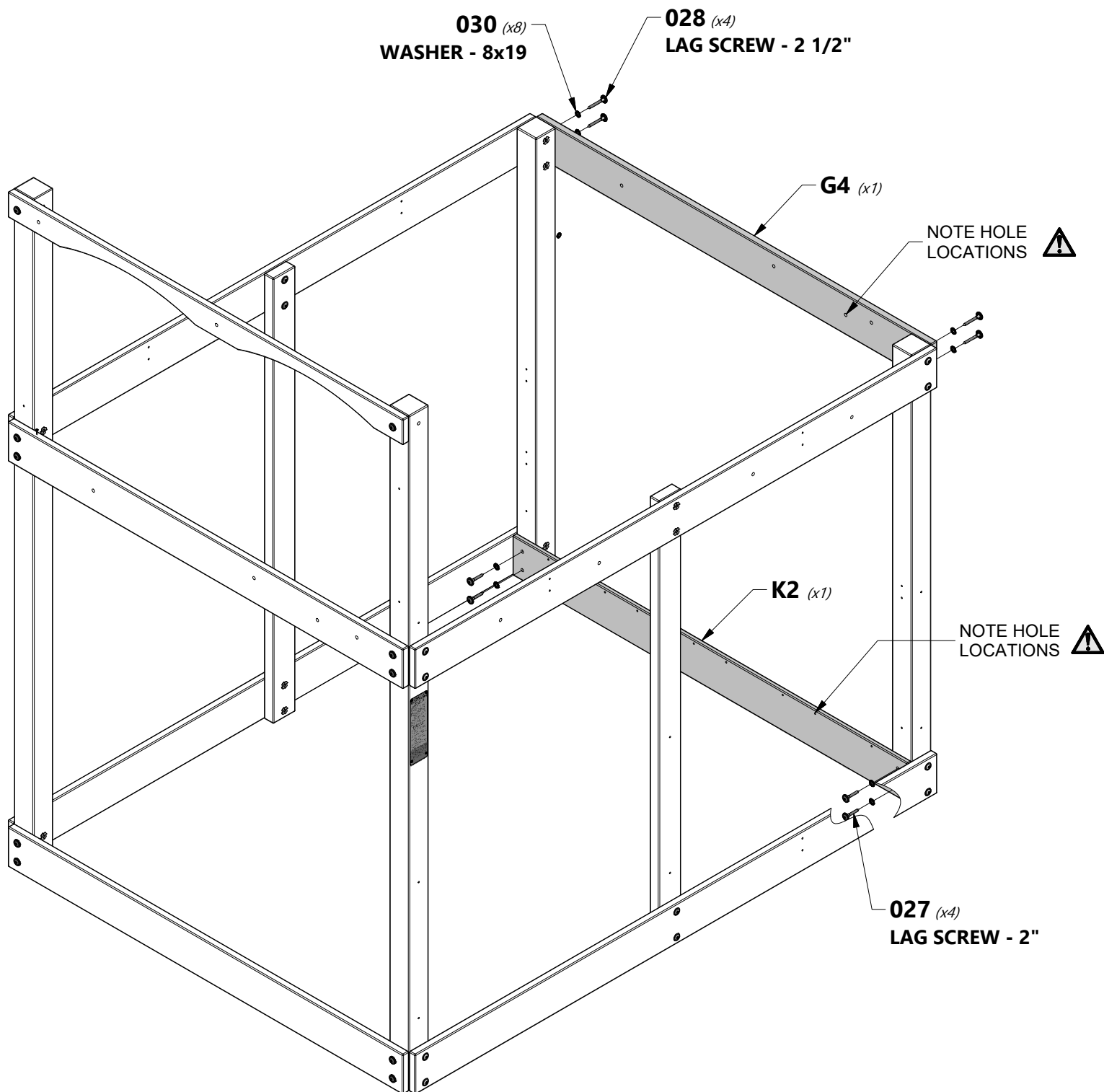



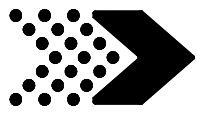

# FORT ASSEMBLY

# STEP 5



**K3** | FLOOR RAIL - W4L04572  
(1) | 5/8"x5 1/4"x60 1/2" (16x134x1537)



**H26** | FLOOR JOIST - W4L04573  
(1) | 1"x3 3/8"x60 1/2" (24x86x1537)



**H100027** | LAG SCREW WH  
(4) | 5/16x2



**H100030** | WASHER LOCK  
(4) | EXT  
8x19



**H100090** | SCREW PFH  
(4) | 8x2 1/2"

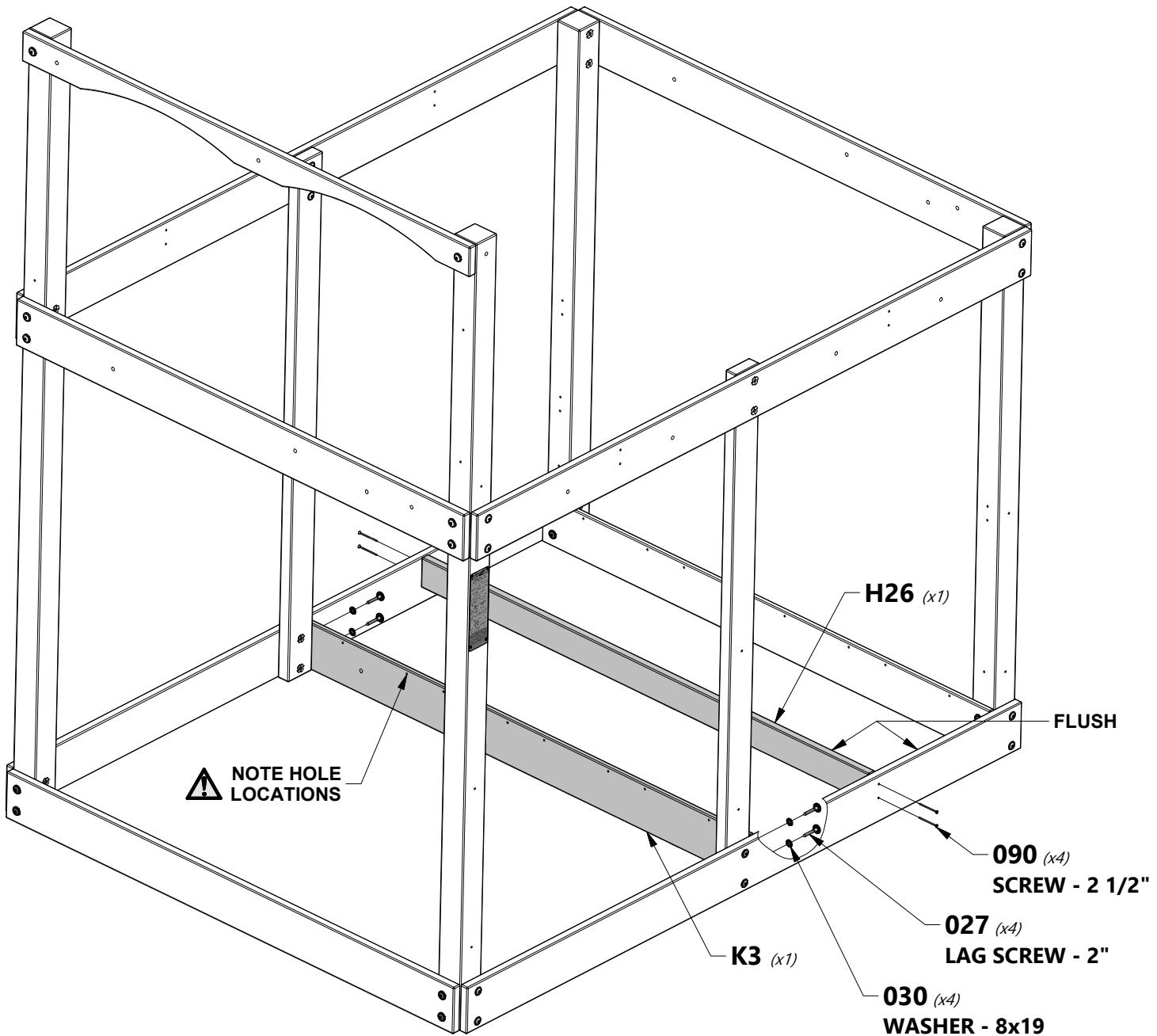

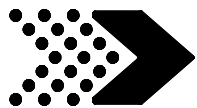

# FORT ASSEMBLY

# STEP 6

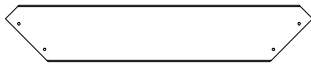

**L2** | SAND BOX SEAT - W4L11776  
(2) | 5/8"x4 3/8"x24" (16x112x610)



**H27** | PICNIC TABLE SUPPORT - W4L04574  
(1) | 1"x3 3/8"x28 5/8" (24x86x728)



**H100086** | SCREW PFH  
(8) | 8x1 1/2



**H100010** | BOLT WH  
(1) | 5/16x1-1/2



**H100030** | WASHER LOCK  
(1) | EXT  
8x19

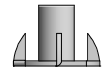

**H100074** | T-NUT  
(1) | 5/16



**TIP:**  
INSTALL T-NUTS INTO  
BOARDS BEFORE ASSEMBLY.

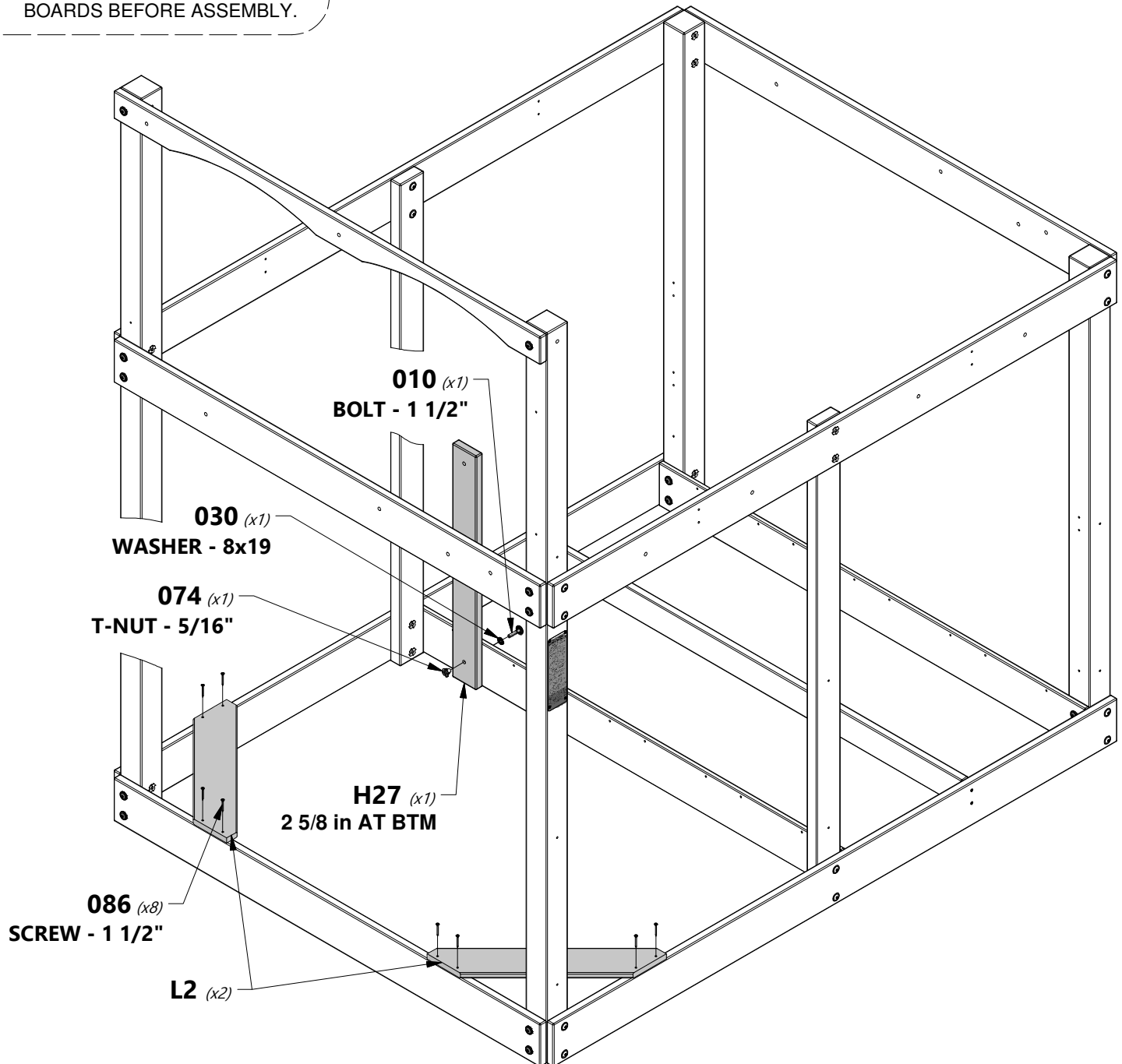

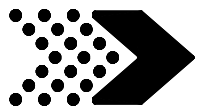

**FP1** | **BOTTOM FLOOR PANEL - W2A01485**  
(4) | 1 5/8"x13 1/2"x35 3/8" (40x344x897)

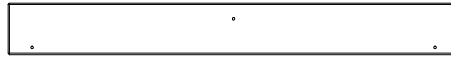

**Y2** | **BOTTOM FLOOR BOARD - W4L04577**  
(2) | 5/8"x4"x35 1/4" (16x102x895)



**H100086** | **SCREW PFH**  
(38) | 8x1 1/2

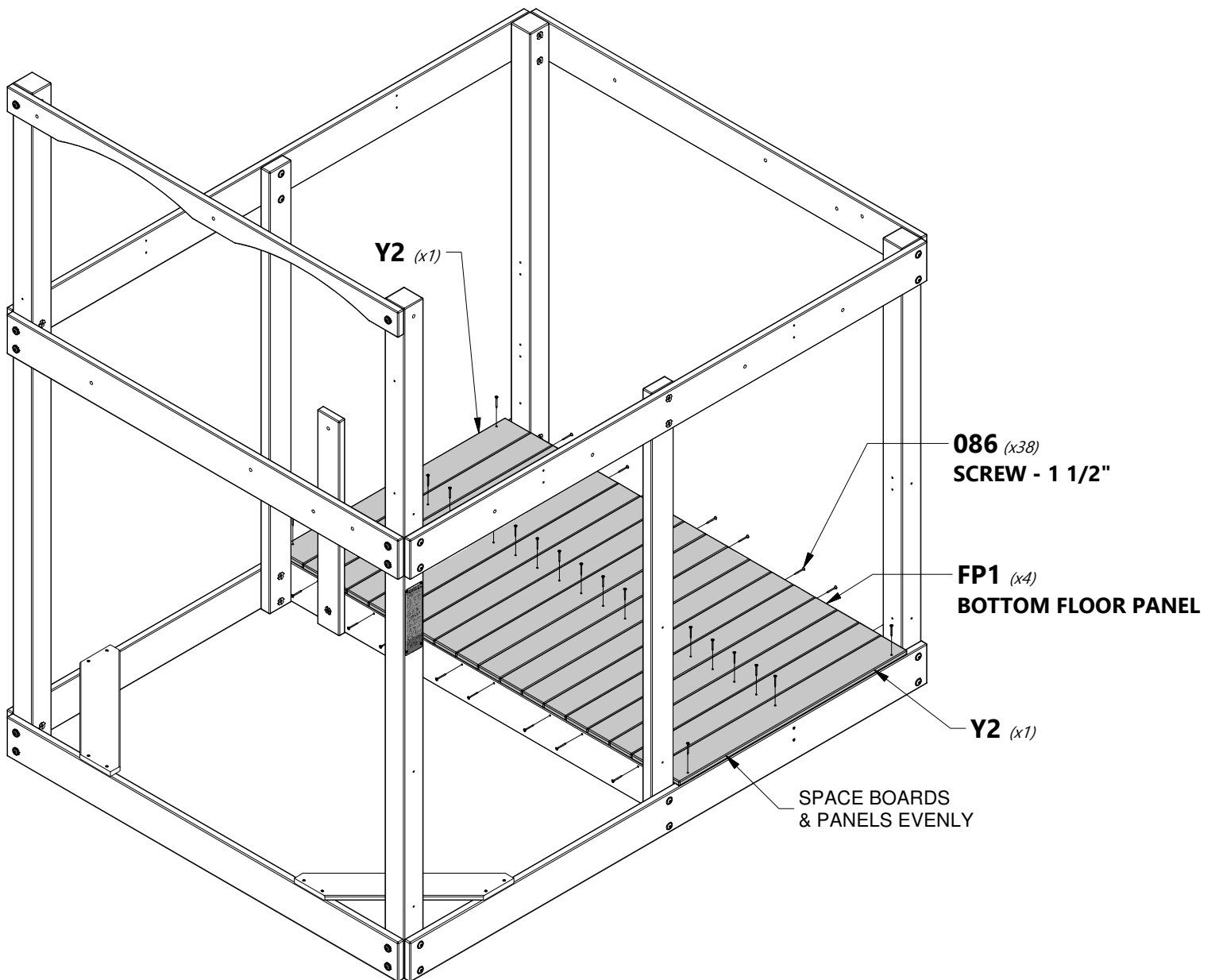



**H3** | PICNIC TABLE RAIL - W4L04578  
(1) | 1"x3 3/8"x67 1/4" (24x86x1708)



**M3** | BOTTOM WALL RAIL - W4L04579  
(1) | 5/8"x3 3/8"x60 1/2" (16x86x1537)



**H100028** | LAG SCREW WH  
(4) | 5/16x2 1/2



**H100030** | WASHER LOCK  
(6) | EXT  
8x19



**H100027** | LAG SCREW WH  
(2) | 5/16x2

NOTE ANGLE CUT  
FACES DOWNWARD

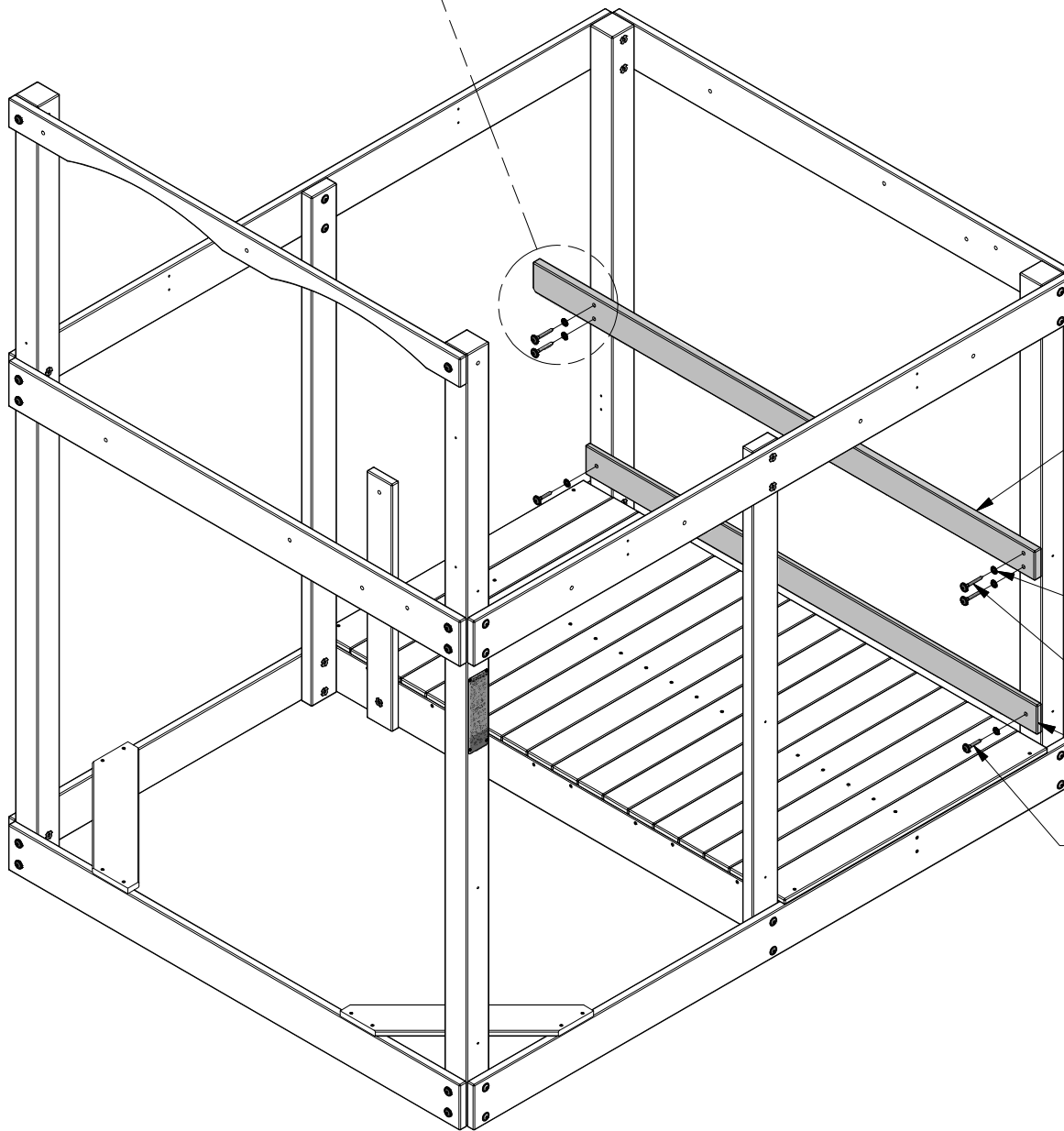
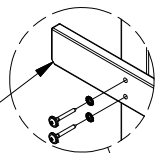

**H3** (x1)

**030** (x6)  
WASHER - 8x19

**028** (x4)  
LAG SCREW - 2 1/2"

**M3** (x1)

**027** (x2)  
LAG SCREW - 2"

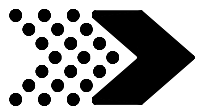

**M27** | **BOTTOM WALL BOARD - W4L15944**  
 (8) | 5/8"x3 3/8"x21 3/8" (16x86x544)

**H100088** | **SCREW PFH**  
 (32) | 8x1 1/8"

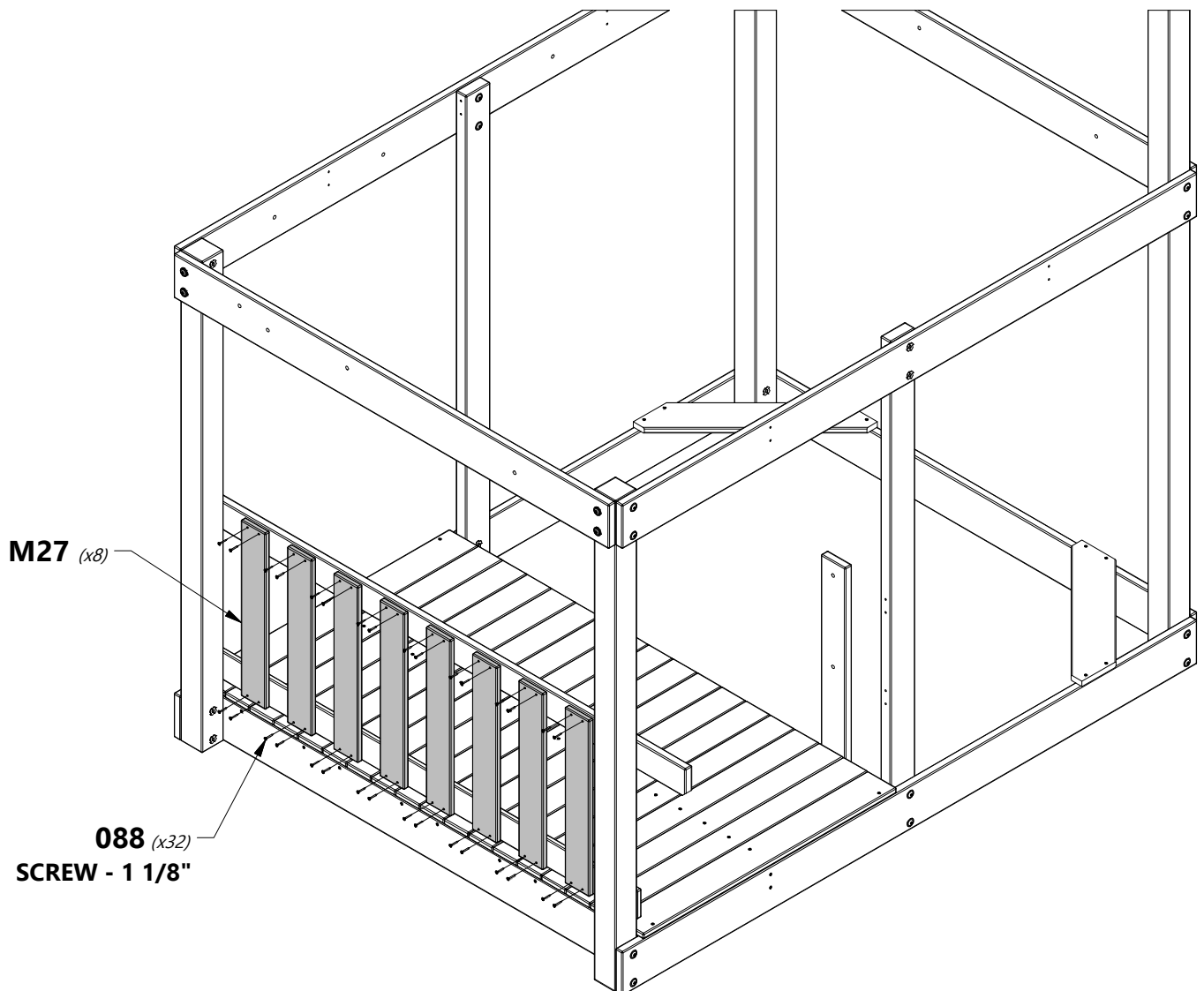
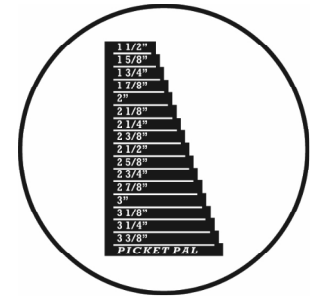
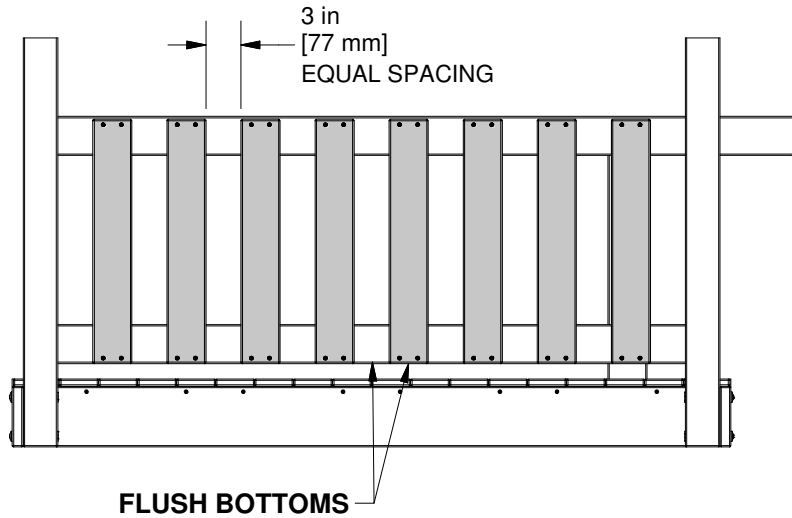

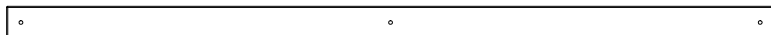
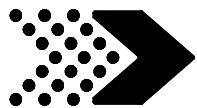

**M2** | BOTTOM WALL RAIL - W4L04596  
(2) | 5/8"x3 3/8"x80" (16x86x2032)



**H100027** | LAG SCREW WH  
(4) | 5/16x2



**H100030** | WASHER LOCK  
(6) | EXT  
8x19

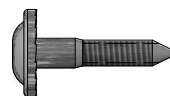

**H100026** | LAG SCREW WH  
(2) | 5/16x1 1/2

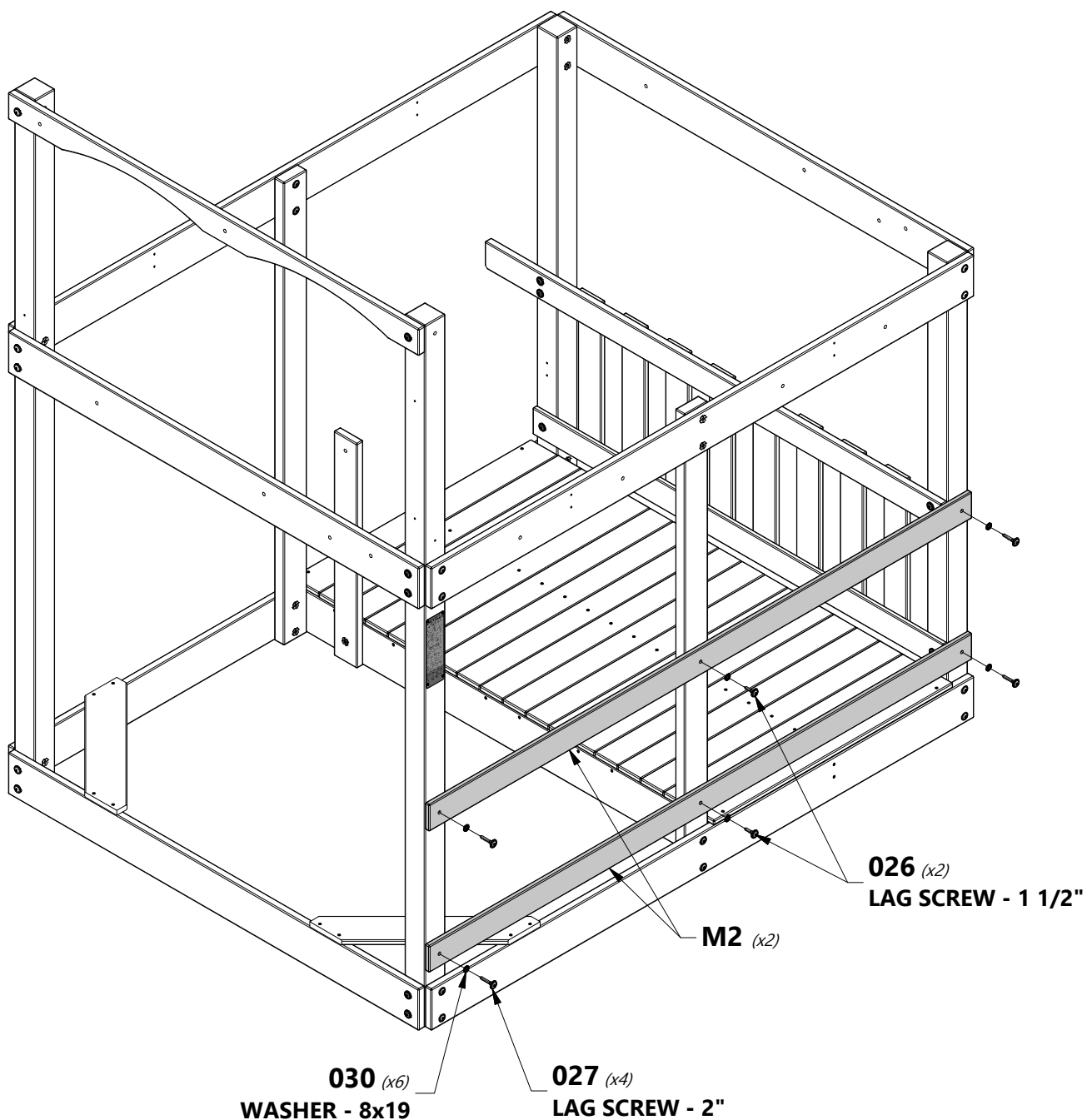

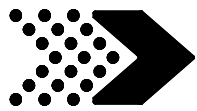

**M27** | **BOTTOM WALL BOARD - W4L15944**  
(10) | 5/8"x3 3/8"x21 3/8" (16x86x544)



**H100088** | **SCREW PFH**  
(40) | 8x1 1/8

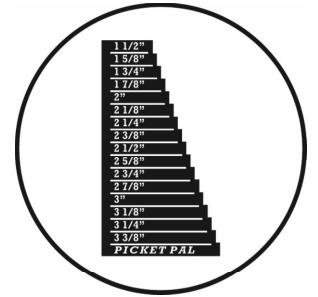
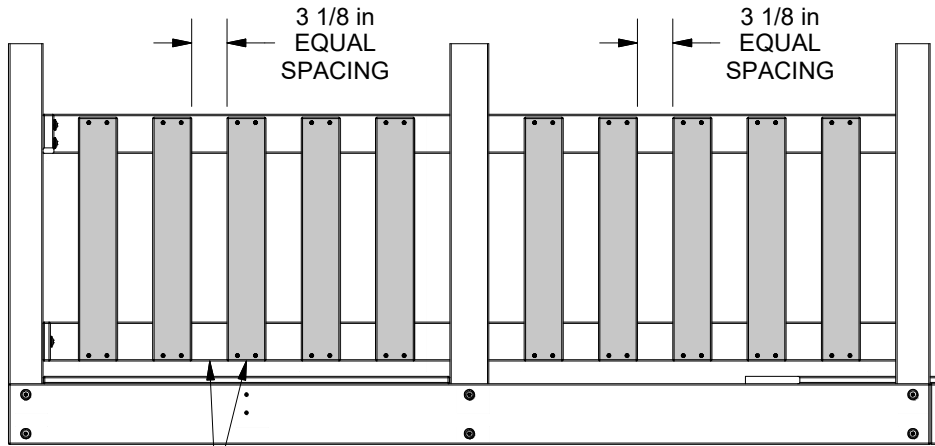

**FLUSH BOTTOMS**

**M27 (x10)**

**088 (x40)**  
**SCREW - 1 1/8"**

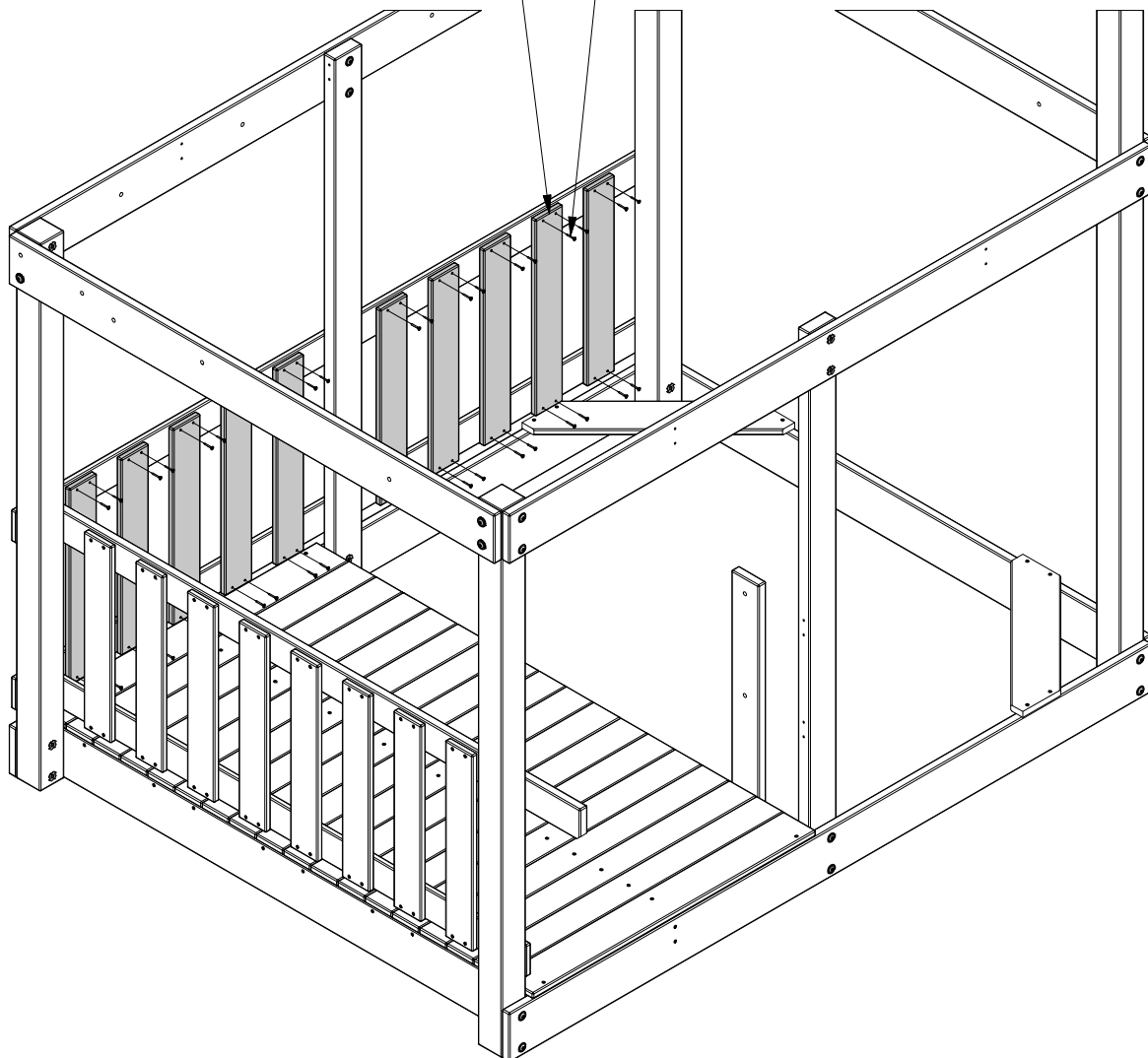



# FORT ASSEMBLY

# STEP 12

**H16** | PICNIC TABLE SEAT RAIL - W4L04597  
 (1) | 1"x3 3/8"x32" (24x86x812)

**H23** | PICNIC TABLE BRACE - W4L04598  
 (1) | 1"x3 3/8"x17 1/2" (24x86x444)



**H100028** | LAG SCREW WH  
 (2) | 5/16x2 1/2



**H100010** | BOLT WH  
 (1) | 5/16x1-1/2



**H100138** | WASHER LOCK  
 (1) | EXT  
 6x15



**H100146** | LAG SCREW WH  
 (1) | 1/4x2



**H100011** | BOLT WH  
 (1) | 5/16x1 3/4



**H100030** | WASHER LOCK  
 (4) | EXT  
 8x19



**H100074** | T-NUT  
 (2) | 5/16



**TIP:**  
 INSTALL T-NUTS INTO BOARDS  
 BEFORE ASSEMBLY

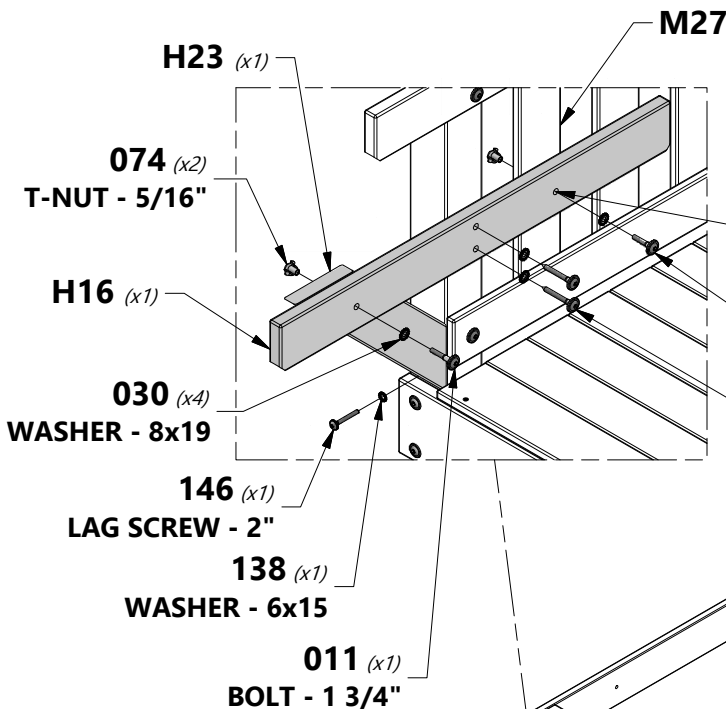

USING 'H16' AS A GUIDE, DRILL  
 3/8" DIAMETER HOLE IN 'M27'

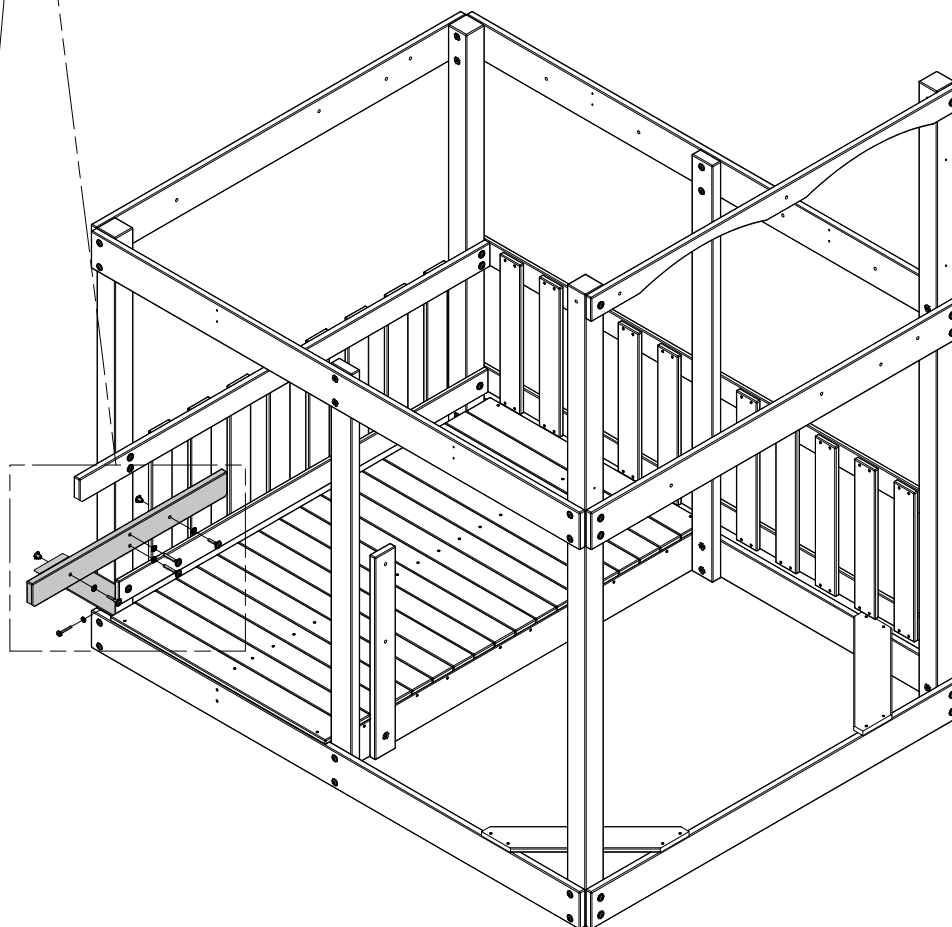



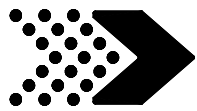

**H17** | PICNIC TABLE SEAT RAIL - W4L04599  
(1) | 1"x3 3/8"x32" (24x86x812)



**H23** | PICNIC TABLE BRACE - W4L04598  
(1) | 1"x3 3/8"x17 1/2" (24x86x444)



**H100028** | LAG SCREW WH  
(2) | 5/16x2 1/2



**H100011** | BOLT WH  
(2) | 5/16x1 3/4

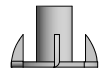

**H100074** | T-NUT  
(2) | 5/16



**H100146** | LAG SCREW WH  
(1) | 1/4x2



**H100030** | WASHER LOCK  
(4) | EXT  
8x19



**H100138** | WASHER LOCK  
(1) | EXT  
6x15

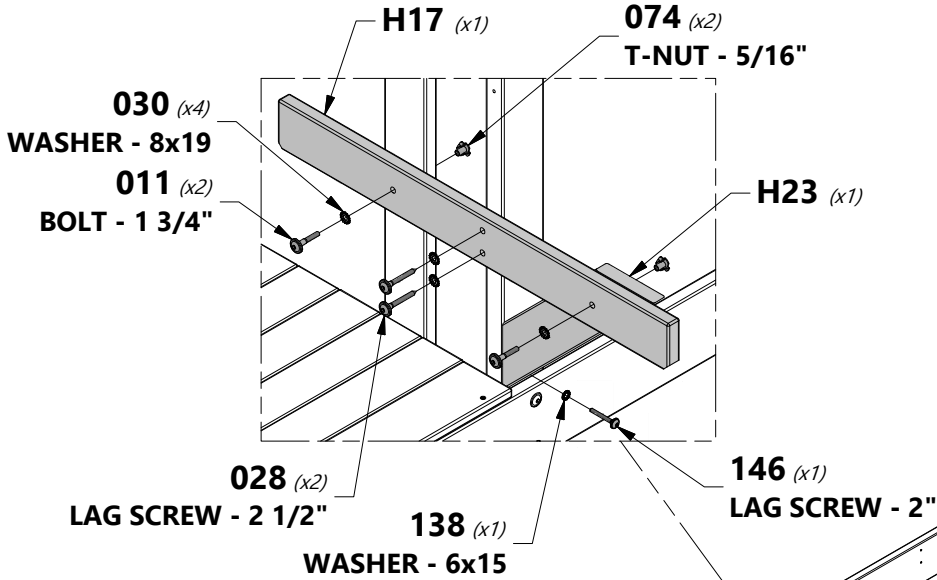

 **TIP:**  
INSTALL T-NUTS INTO  
BOARDS BEFORE ASSEMBLY.

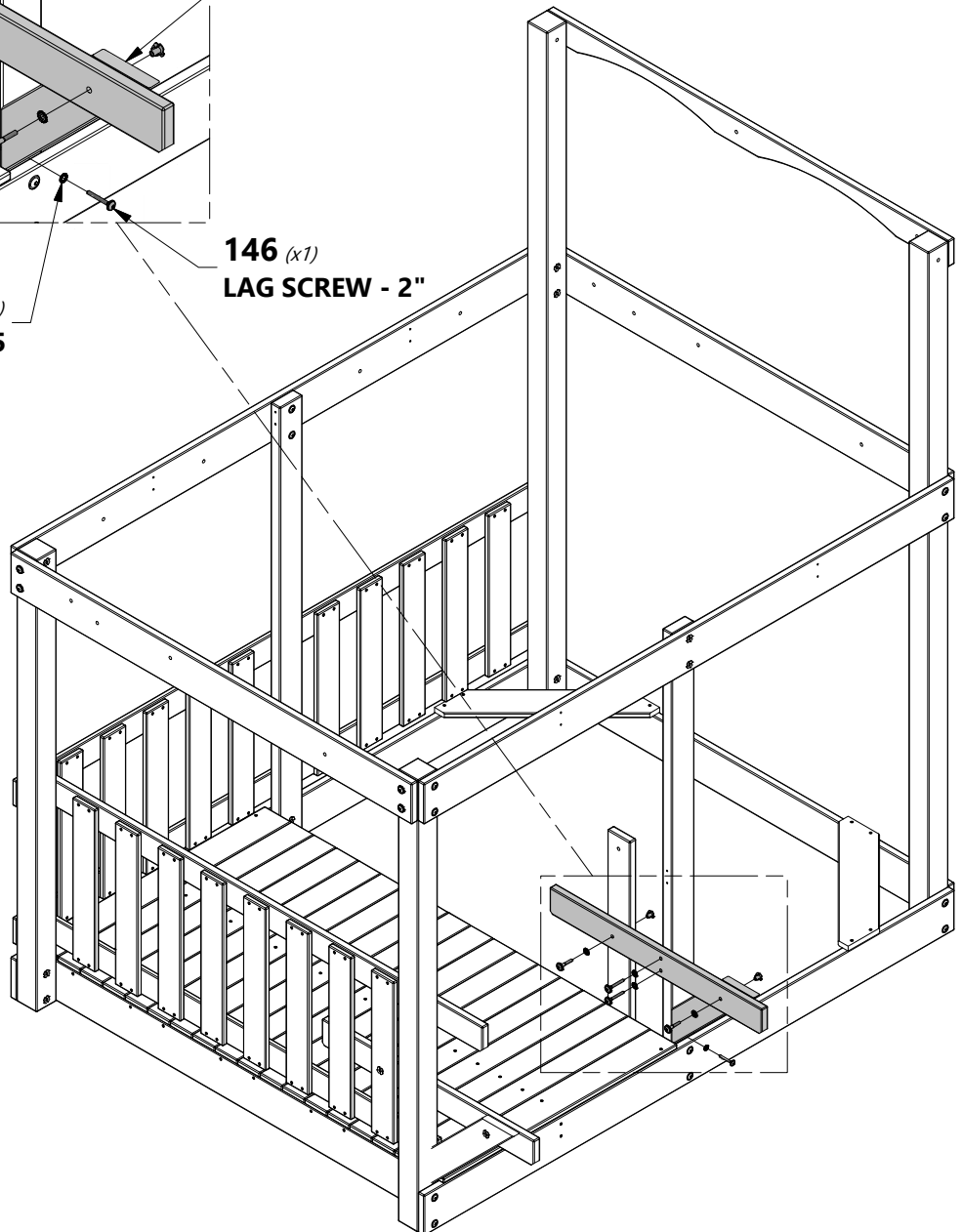

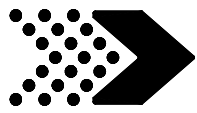

**H15** | PICNIC TABLE SEAT - W4L04600  
(4) | 1"x3 3/8"x35 3/8" (24x86x897)



**H100111** | SCREW PFH  
(16) | 8x2

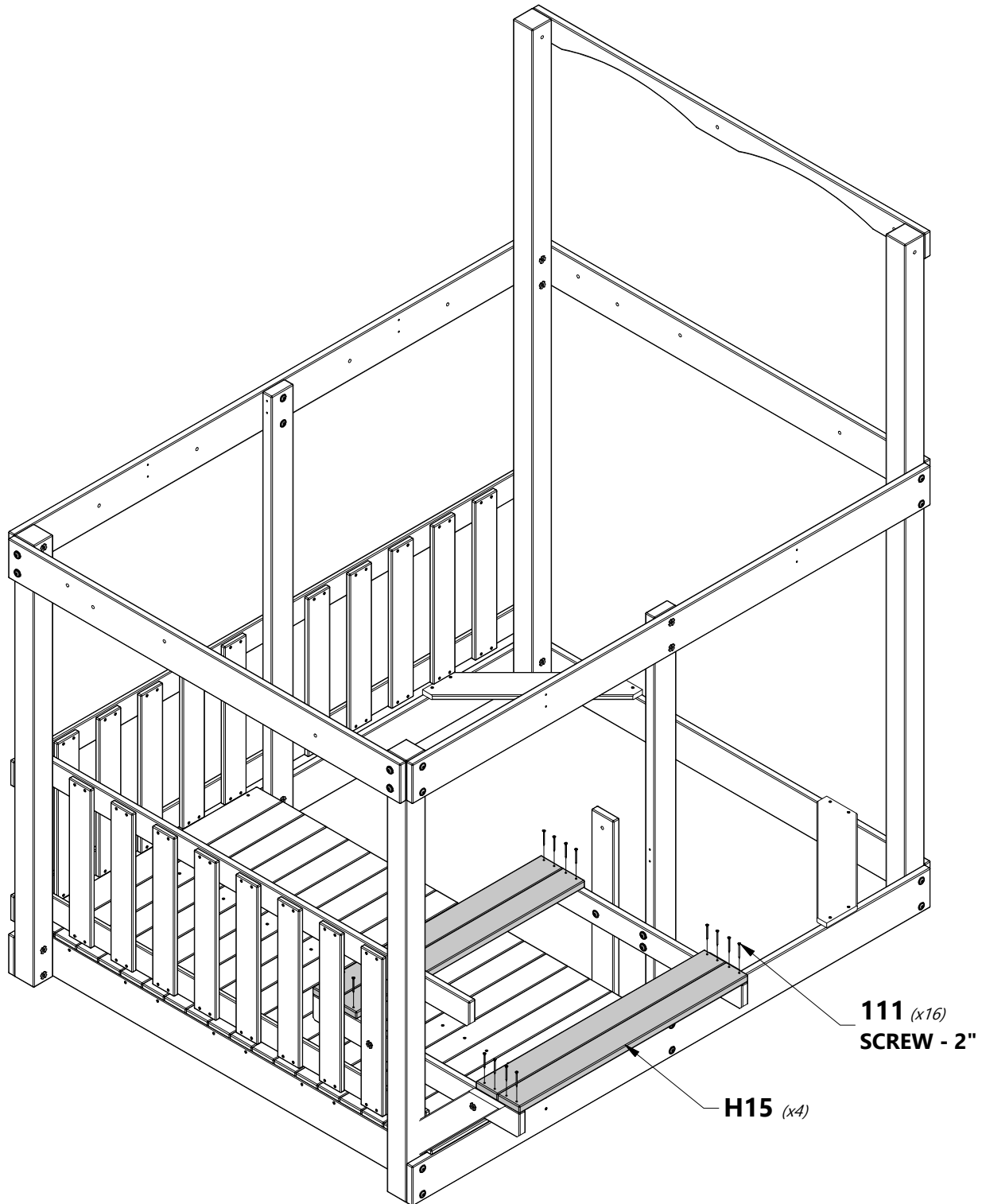

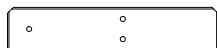
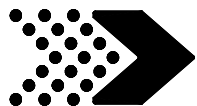

**H24** | PICNIC TABLE TOP SUPPORT - W4L04601  
(1) | 1"x3 3/8"x16 1/2" (24x86x418)



**H100011** | BOLT WH  
(1) | 5/16x1 3/4



**H100028** | LAG SCREW WH  
(2) | 5/16x2 1/2



**H100074** | T-NUT  
(1) | 5/16



**H100030** | WASHER LOCK  
(3) | EXT  
8x19



**TIP:**  
INSTALL T-NUTS INTO  
BOARDS BEFORE ASSEMBLY.

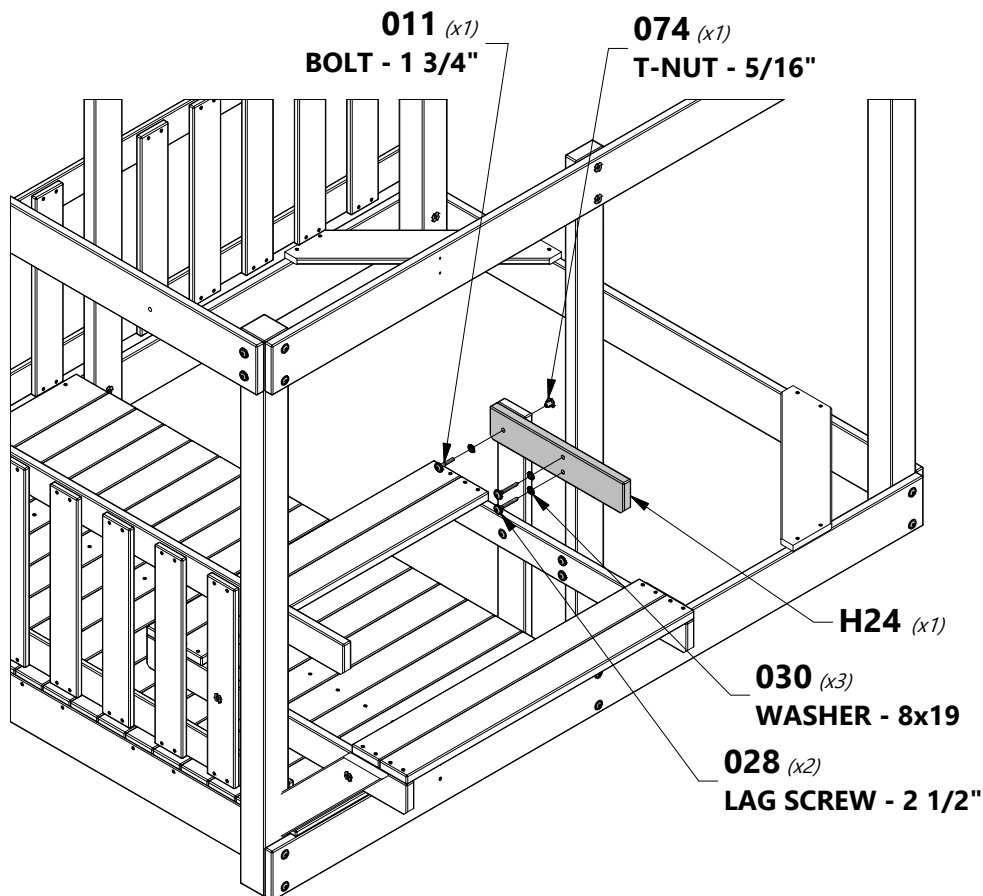



**M16** | CENTER PICNIC TABLE TOP - W4L04603  
(1) | 5/8"x3"x38 1/4" (16x76x973)



**M13** | PICNIC TABLE TOP - W4L04602  
(4) | 5/8"x3 3/8"x41 1/4" (16x86x1049)

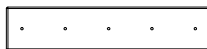

**M30** | PICNIC TABLE TOP CLEAT - W4L04604  
(1) | 5/8"x3 3/8"x16" (16x86x406)



**H100086** | SCREW PFH  
(20) | 8x1 1/2



**H100088** | SCREW PFH  
(5) | 8x1 1/8

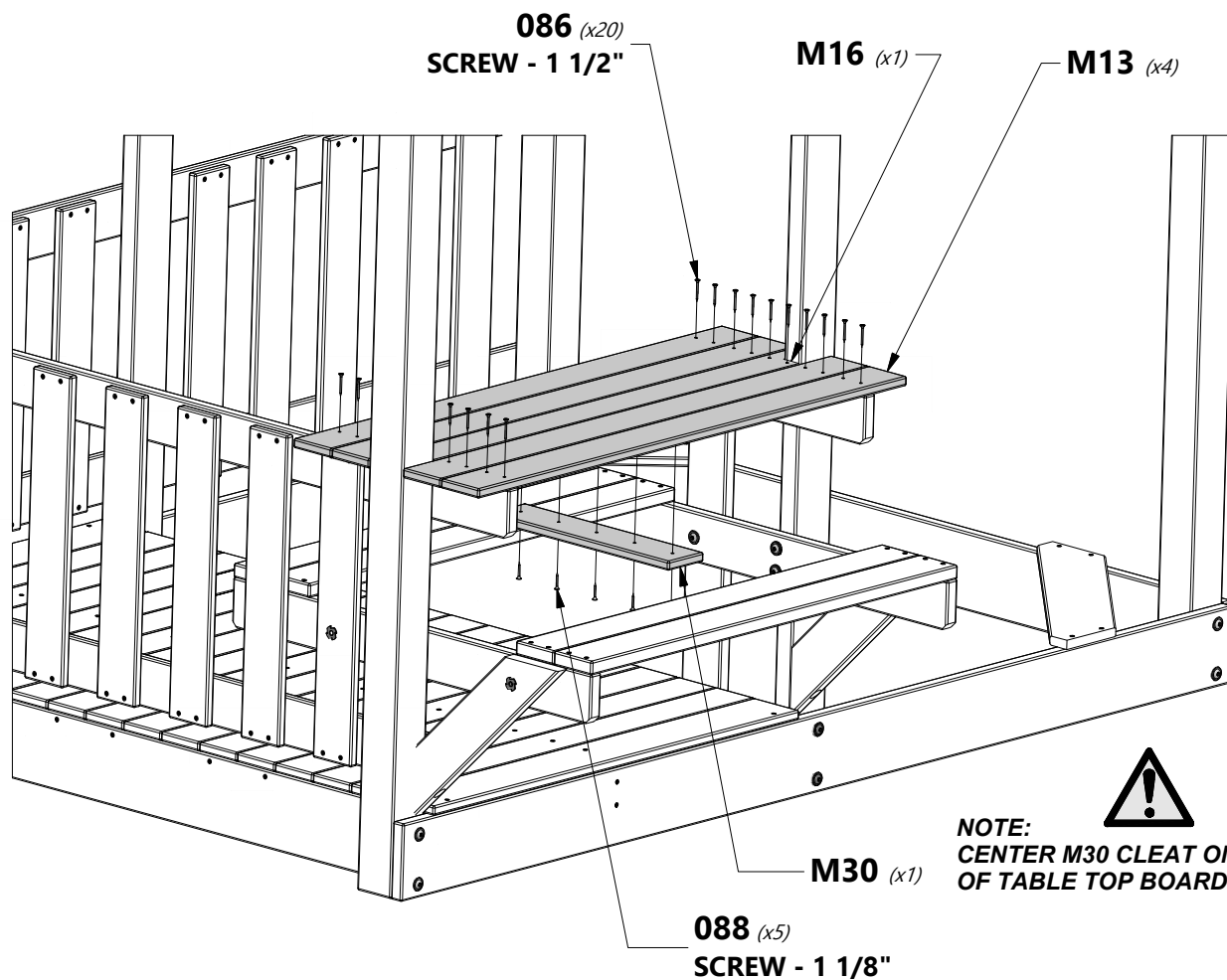

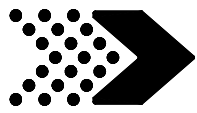

**H25** | TOP FLOOR SUPPORT - W4L04606  
(2) | 1"x3 3/8"x3" (24x86x76)



**H100111** | SCREW PFH  
(4) | 8x2

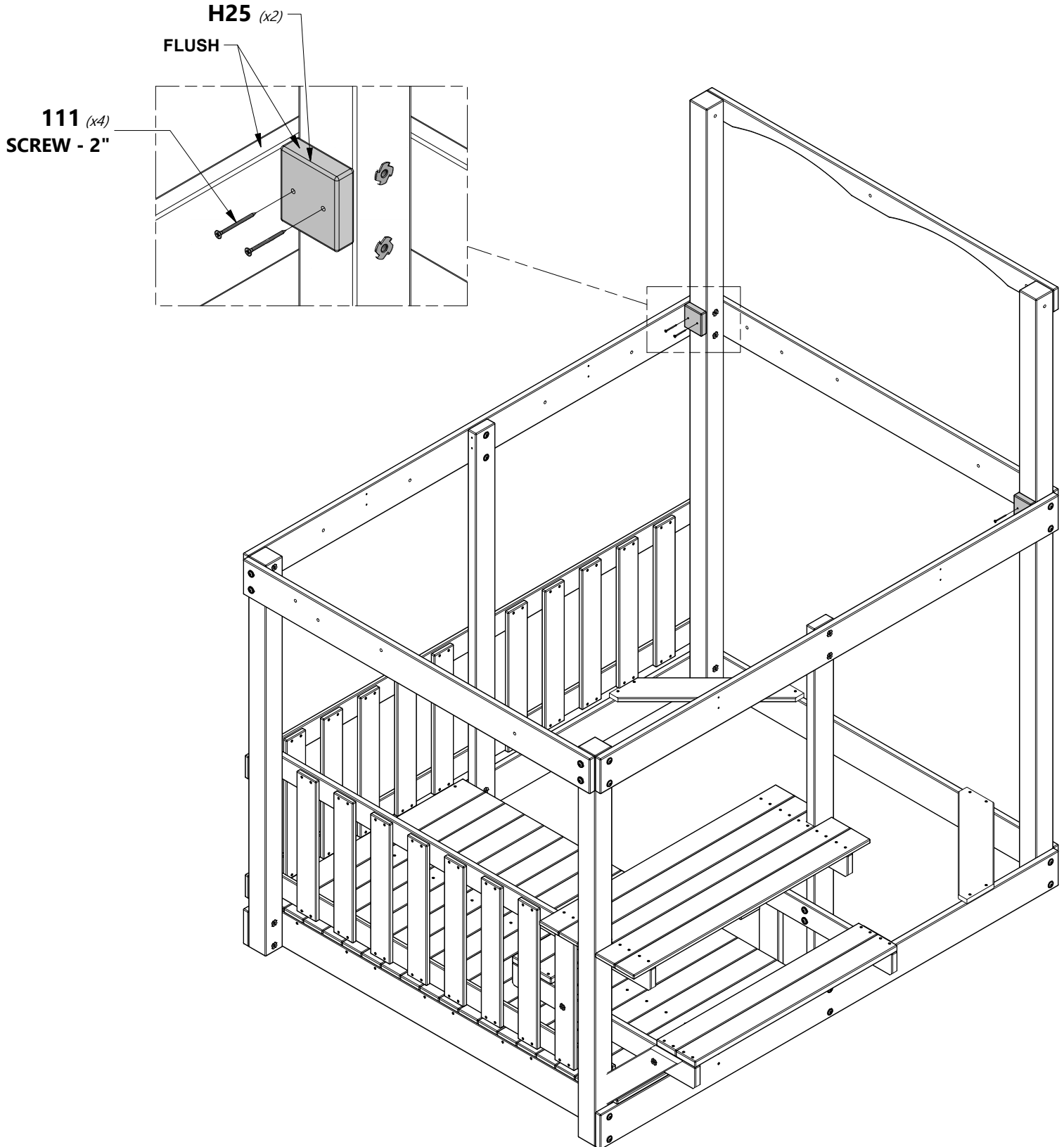

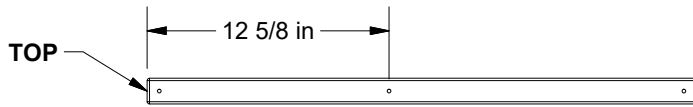
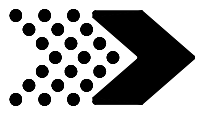

**O2** SAFETY BOARD - W4L04605  
(1) 5/8"x1 3/8"x28 5/8" (16x34x726)



**H100088** SCREW PFH  
(3) 8x1 1/8

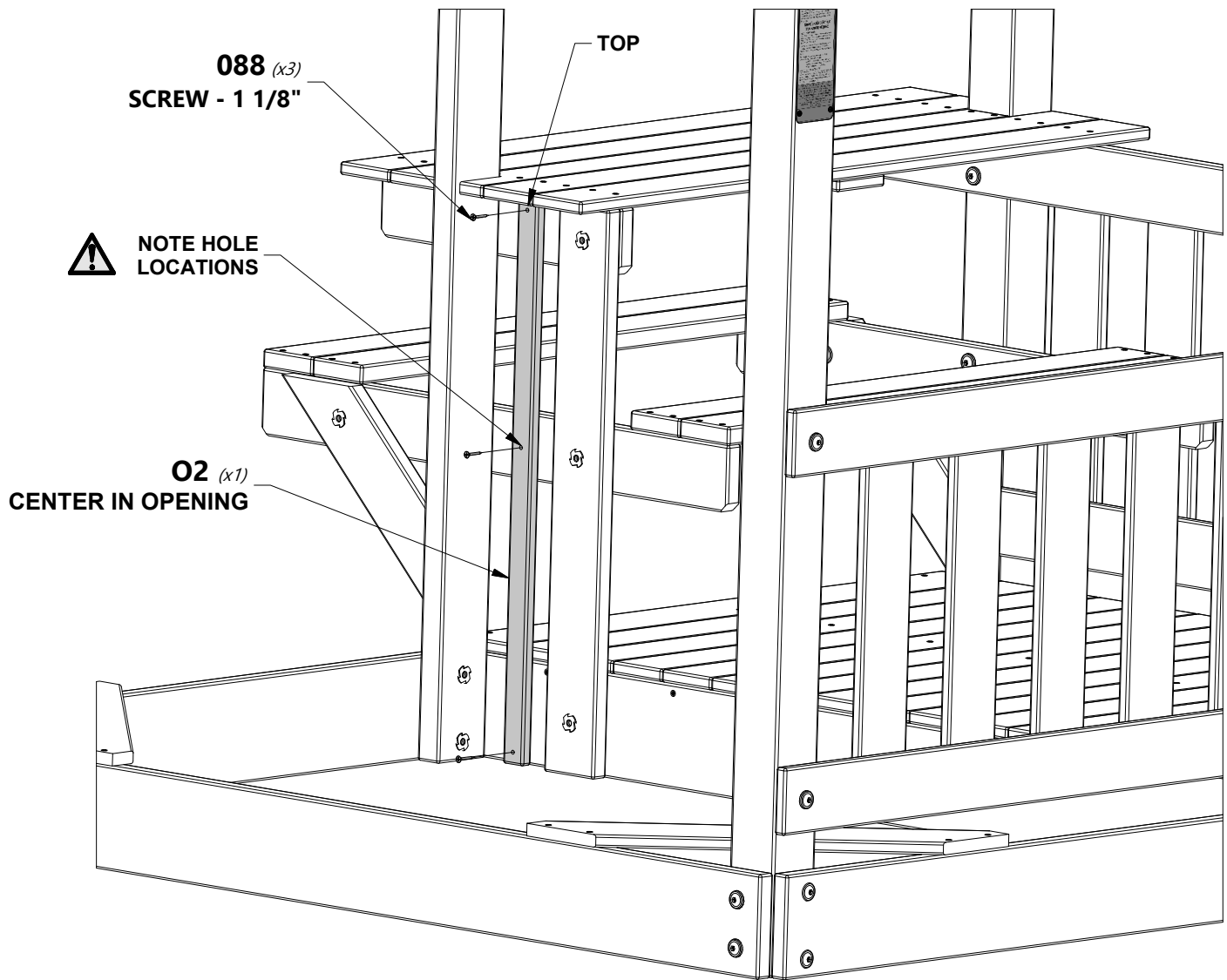

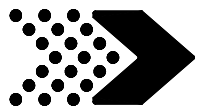

# FORT ASSEMBLY

# STEP 19

**E6** | DECK BRACE - W4L15942  
 (8) | 1 7/16"x3 3/8"x20" (36x86x508)

**H100013** | BOLT WH  
 (8) | 5/16x2 1/4

**H100074** | T-NUT  
 (8) | 5/16



**H100138** | WASHER LOCK  
 (8) | EXT  
 6x15

**H100649** | LAG SCREW WH  
 (8) | 1/4x2 1/2

**H100030** | WASHER LOCK  
 (8) | EXT  
 8x19

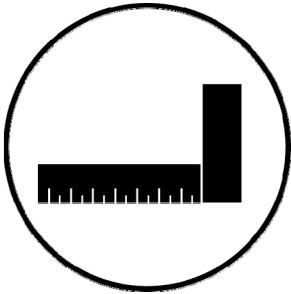

**TIP:**  
 INSTALL T-NUTS INTO  
 BOARDS BEFORE ASSEMBLY.

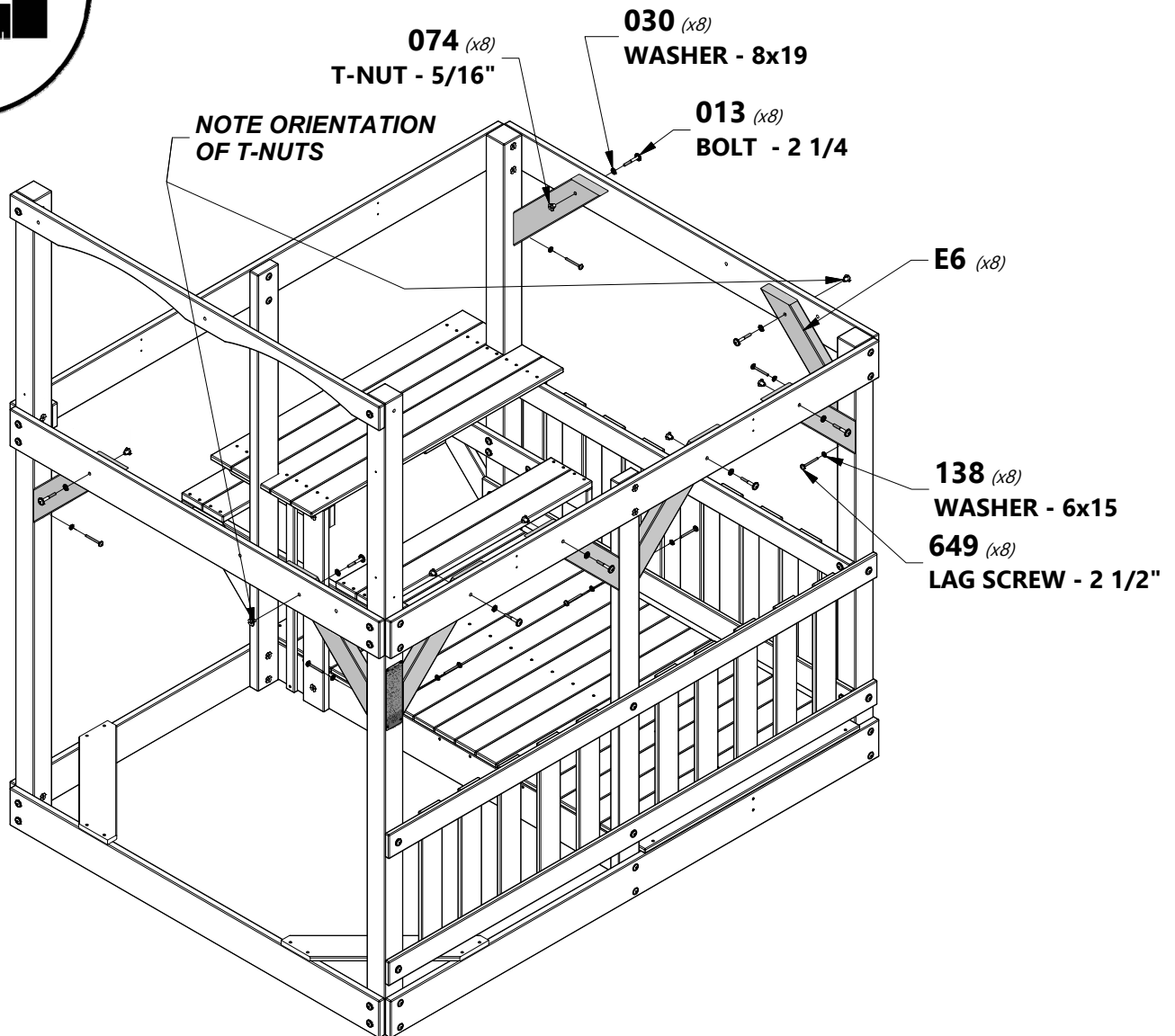

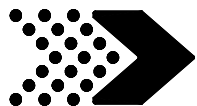

**H5** | FLOOR RAIL - W4L04608  
(1) | 1"x3 3/8"x60 1/2" (24x86x1537)



**H26** | FLOOR JOIST - W4L04573  
(2) | 1"x3 3/8"x60 1/2" (24x86x1537)



**H100027** | LAG SCREW WH  
(4) | 5/16x2



**H100030** | WASHER LOCK  
(4) | EXT  
8x19



**H100090** | SCREW PFH  
(8) | 8x2 1/2"

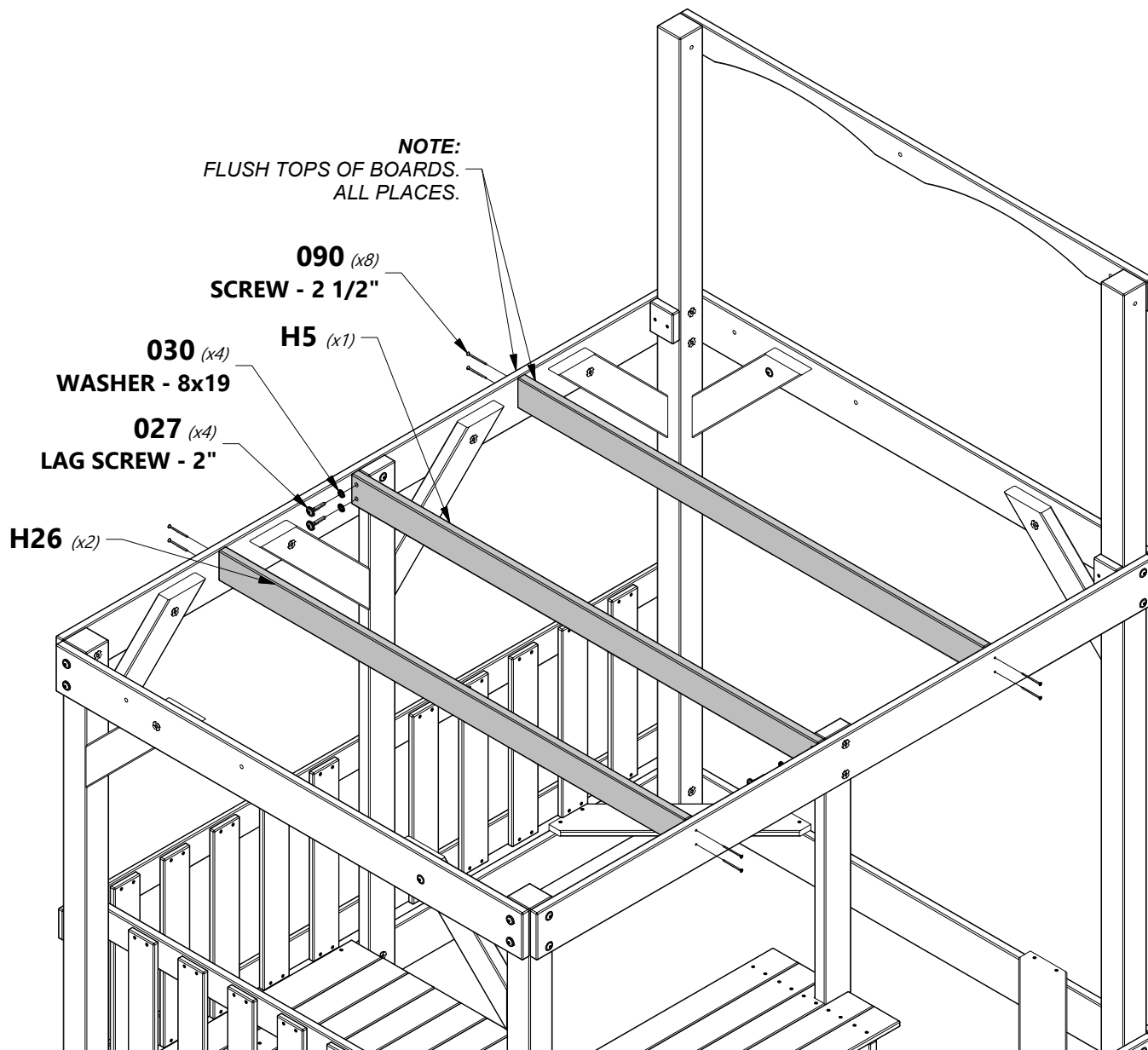



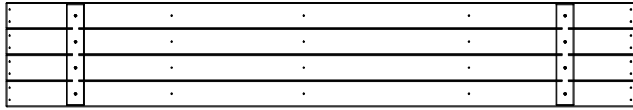

**FP2 | FLOOR PANEL - W2A03345**  
(4) | 1 1/4"x13 1/2"x81 7/8" (32x344x2080)

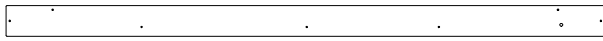

**Y1 | TOP FLOOR BOARD - W4L15964**  
(2) | 5/8"x4"x78" (16x102x1980)



**H100086 | SCREW PFH**  
(126) | 8x1 1/2



**H100074 | T-NUT**  
(2) | 5/16

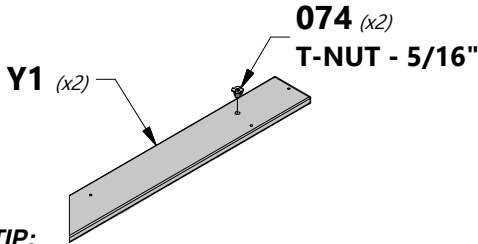

**NOTE:**  
ENSURE PILOT HOLES ARE  
CENTERED ON FLOOR JOISTS.

**NOTE:**  
T-NUTS THESE HOLES  
ON BOTTOM SIDE.

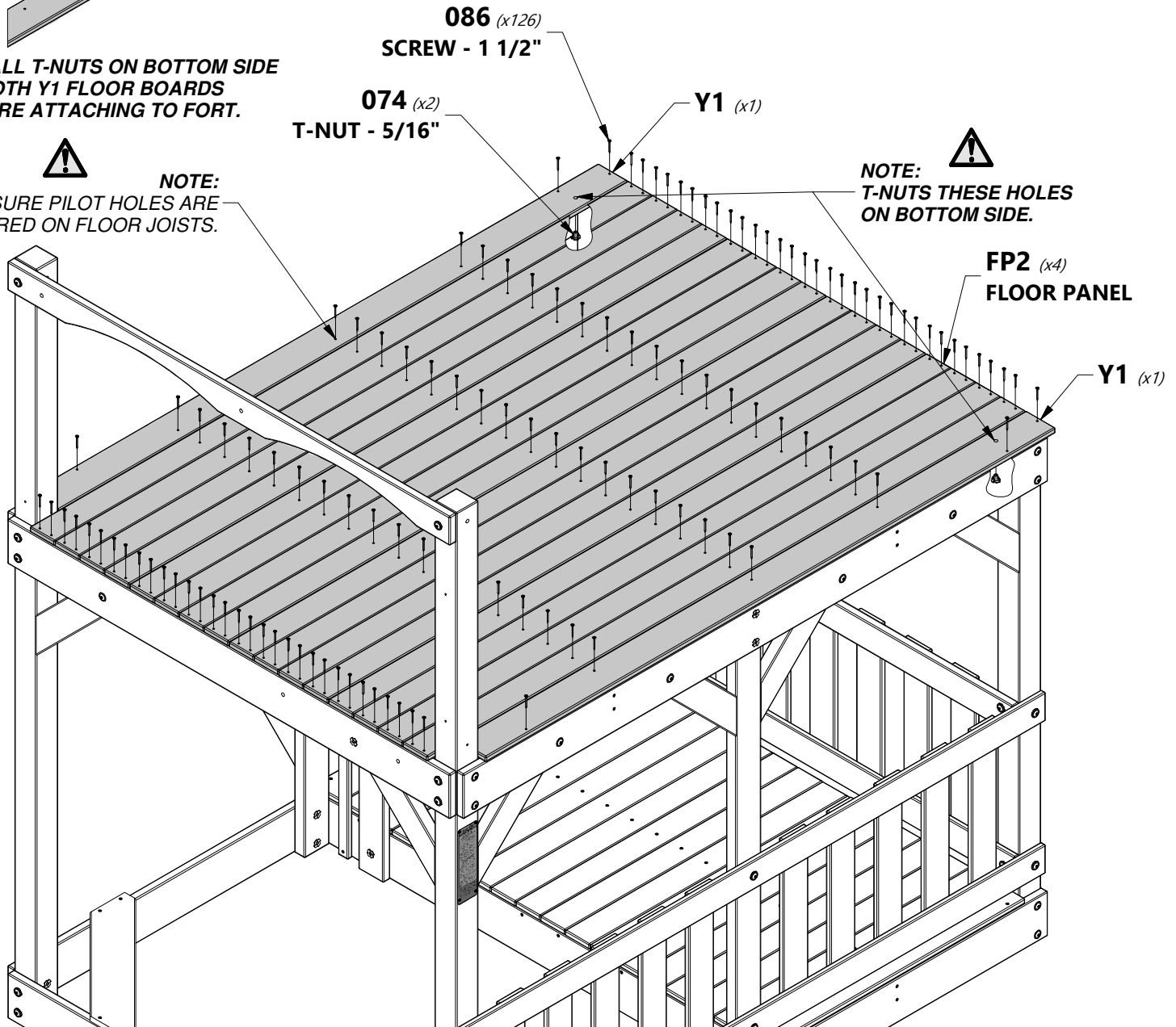



1 3/4 in  
[43 mm]

1 1/2 in  
[38 mm]

**B8** | BACK RIGHT CLUB HOUSE CORNER - W4L04618  
(1) | 3"x3"x53 7/8" (76x76x1370)

**M21** | CLUB HOUSE WALL RAIL - W4L04613  
(1) | 5/8"x3 3/8"x30 1/4" (16x86x768)

**H4** | ROOF SUPPORT RAIL - W4L04623  
(1) | 1"x3 3/8"x67 1/4" (24x86x1709)



**A4M01046** | L BRACKET  
(2) | 2.5x38x55x55

**B5** | BACK LEFT CLUB HOUSE CORNER - W4L04612  
(1) | 3"x3"x53 7/8" (76x76x1370)

**H6** | BACK CLUB HOUSE RAIL - W4L04621  
(1) | 1"x3 3/8"x60 1/2" (24x86x1537)



**H100014** | BOLT WH  
(1) | 5/16x2 1/2



**H100115** | BOLT WH  
(2) | 5/16x1/2



**H100019** | BOLT WH  
(2) | 5/16x3 3/4



**H100030** | WASHER LOCK  
(4) | EXT  
8x19



**H100017** | BOLT WH  
(1) | 5/16x3 1/4

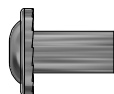

**H100005** | NUT BARREL WH  
(2) | 5/16x7/8



**H100027** | LAG SCREW WH  
(2) | 5/16x2



**H100031** | WASHER LOCK  
(2) | EXT  
12x19



**H100074** | T-NUT  
(2) | 5/16



**TIP:**  
INSTALL T-NUTS INTO  
BOARDS BEFORE ASSEMBLY.

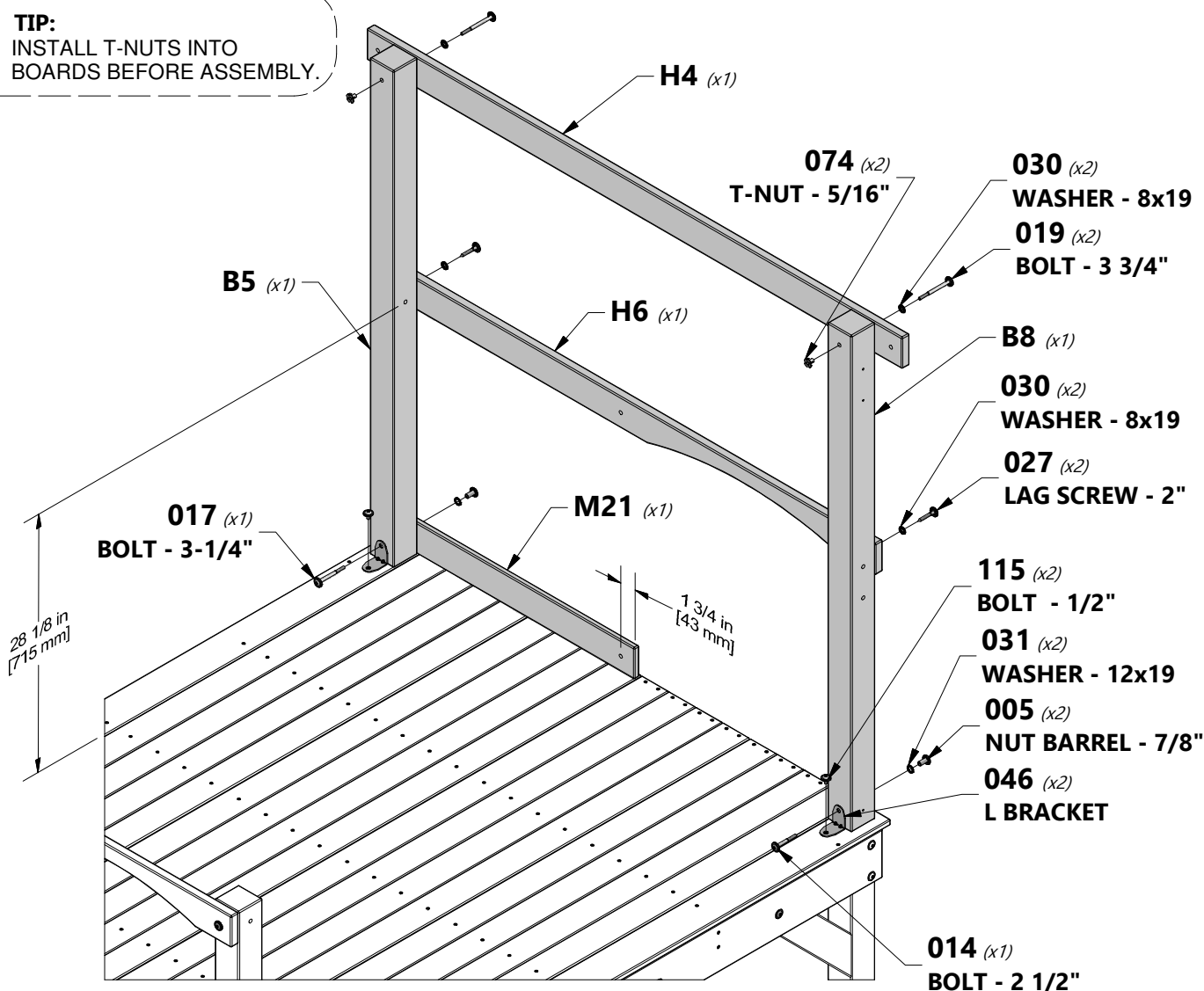

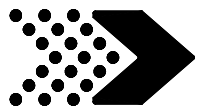

**M10** | CLUB HOUSE WALL RAIL - W4L04614  
(1) | 5/8"x3 3/8"x50 1/4" (16x86x1277)

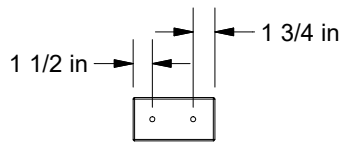

**M34** | WALL RAIL - W4L04611  
(1) | 5/8"x3 3/8"x6 3/8" (16x86x162)



**H100027** | LAG SCREW WH  
(4) | 5/16x2



**H100030** | WASHER LOCK EXT  
(4) | 8x19



**M1** | TOP WALL RAIL - W4L04619  
(1) | 5/8"x3 3/8"x80" (16x86x2032)

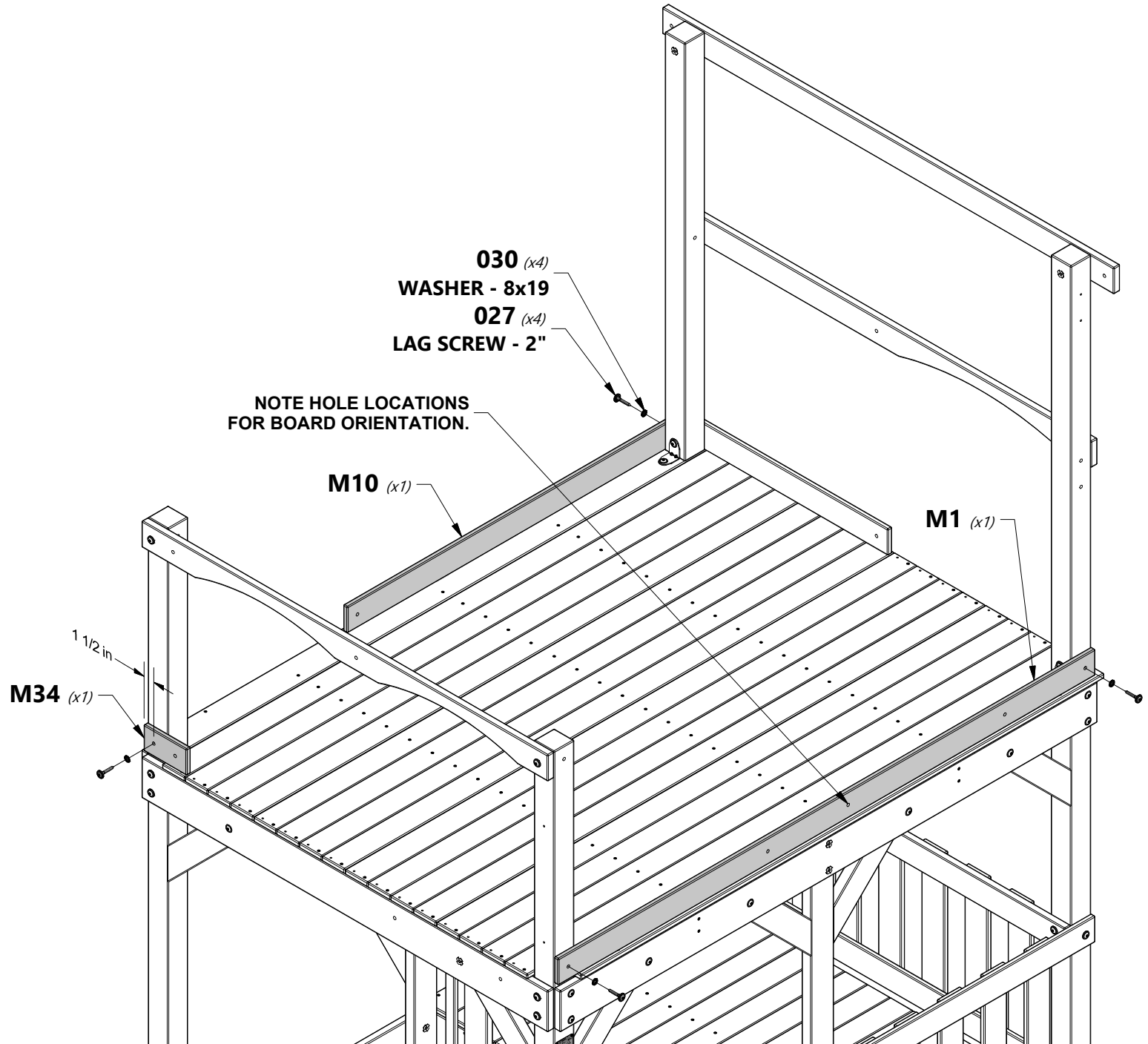

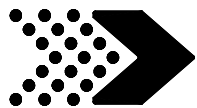

**H18** | CLUB HOUSE WALL RAIL - W4L04616  
(1) | 1"x3 3/8"x29 7/8" (24x86x758)



**A4M01046** | L BRACKET 2.5x38x55x55  
(1)



**H100011** | BOLT WH  
(1) | 5/16x1 3/4

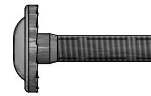

**H100009** | BOLT WH  
(1) | 5/16x1 1/4



**H100115** | BOLT WH  
(1) | 5/16x1/2



**H100074** | T-NUT  
(2) | 5/16



**H100005** | NUT BARREL WH  
(1) | 5/16x7/8



**H100031** | WASHER LOCK  
(1) | EXT  
12x19



**H100030** | WASHER LOCK  
(1) | EXT  
8x19



**TIP:**  
INSTALL T-NUTS INTO  
BOARDS BEFORE ASSEMBLY.

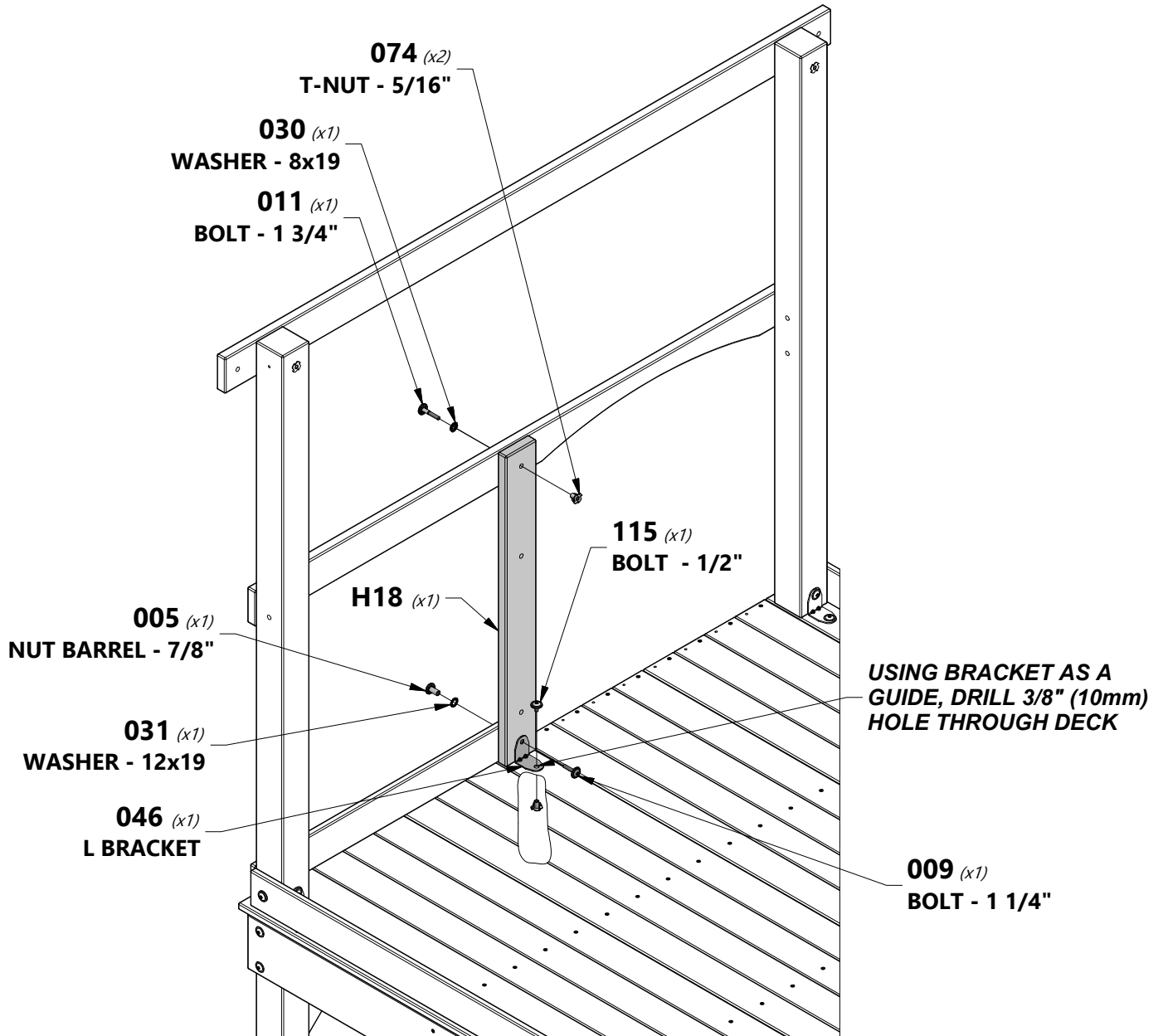

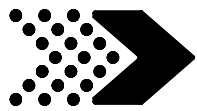

**A4M01046** | L BRACKET  
(1) | 2.5x38x55x55



**H1** | WALL RAIL - W4L04620  
(1) | 1"x3 3/8"x80" (24x86x2032)

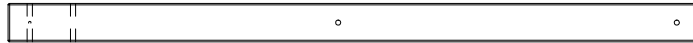

**B6** | FRONT LEFT CLUB HOUSE CORNER - W4L04615  
(1) | 3"x3"x53 7/8" (76x76x1370)

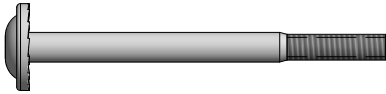

**H100019** | BOLT WH  
(3) | 5/16x3 3/4

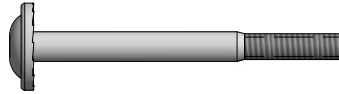

**H100017** | BOLT WH  
(1) | 5/16x3 1/4



**H100005** | NUT BARREL WH  
(1) | 5/16x7/8



**H100115** | BOLT WH  
(1) | 5/16x1/2



**H100074** | T-NUT  
(4) | 5/16



**H100031** | WASHER LOCK  
(1) | EXT  
12x19



**H100030** | WASHER LOCK  
(3) | EXT  
8x19



**TIP:**  
INSTALL T-NUTS INTO  
BOARDS BEFORE ASSEMBLY.

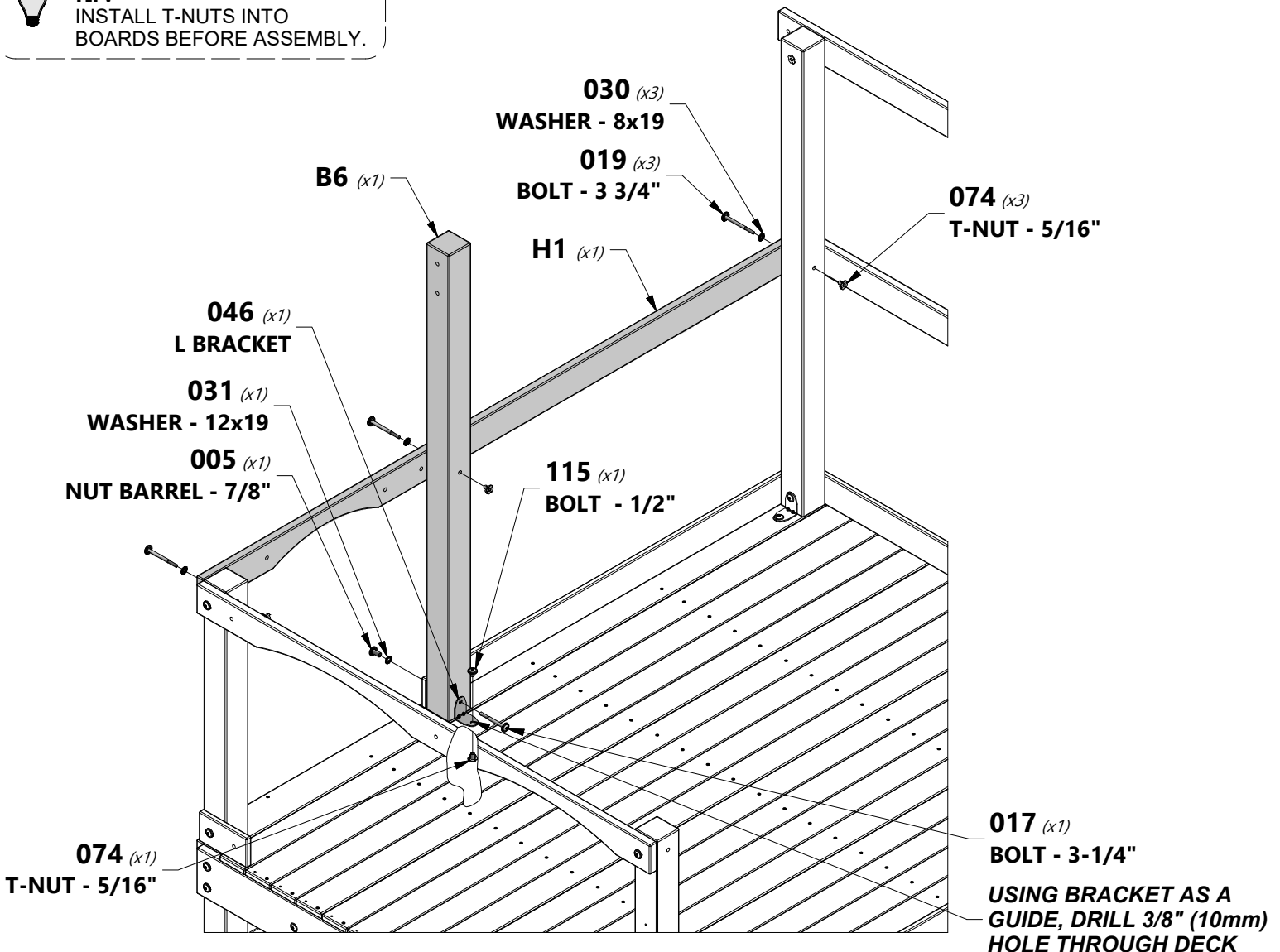



**A4M01046 | L BRACKET**  
(1) | 2.5x38x55x55



**H2 | WALL RAIL - W4L15900**  
(1) | 1"x3 3/8"x80" (24x86x2032)

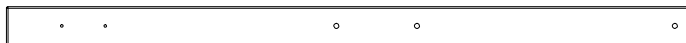

**B7 | FRONT RIGHT CLUB HOUSE CORNER - W4L04617**  
(1) | 3"x3"x53 7/8" (76x76x1370)



**H100019 | BOLT WH**  
(3) | 5/16x3 3/4



**H100017 | BOLT WH**  
(1) | 5/16x3 1/4

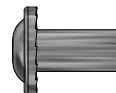

**H100005 | NUT BARREL WH**  
(1) | 5/16x7/8



**H100115 | BOLT WH**  
(1) | 5/16x1/2



**H100030 | WASHER LOCK**  
(3) | EXT  
8x19



**H100031 | WASHER LOCK**  
(1) | EXT  
12x19



**H100074 | T-NUT**  
(4) | 5/16

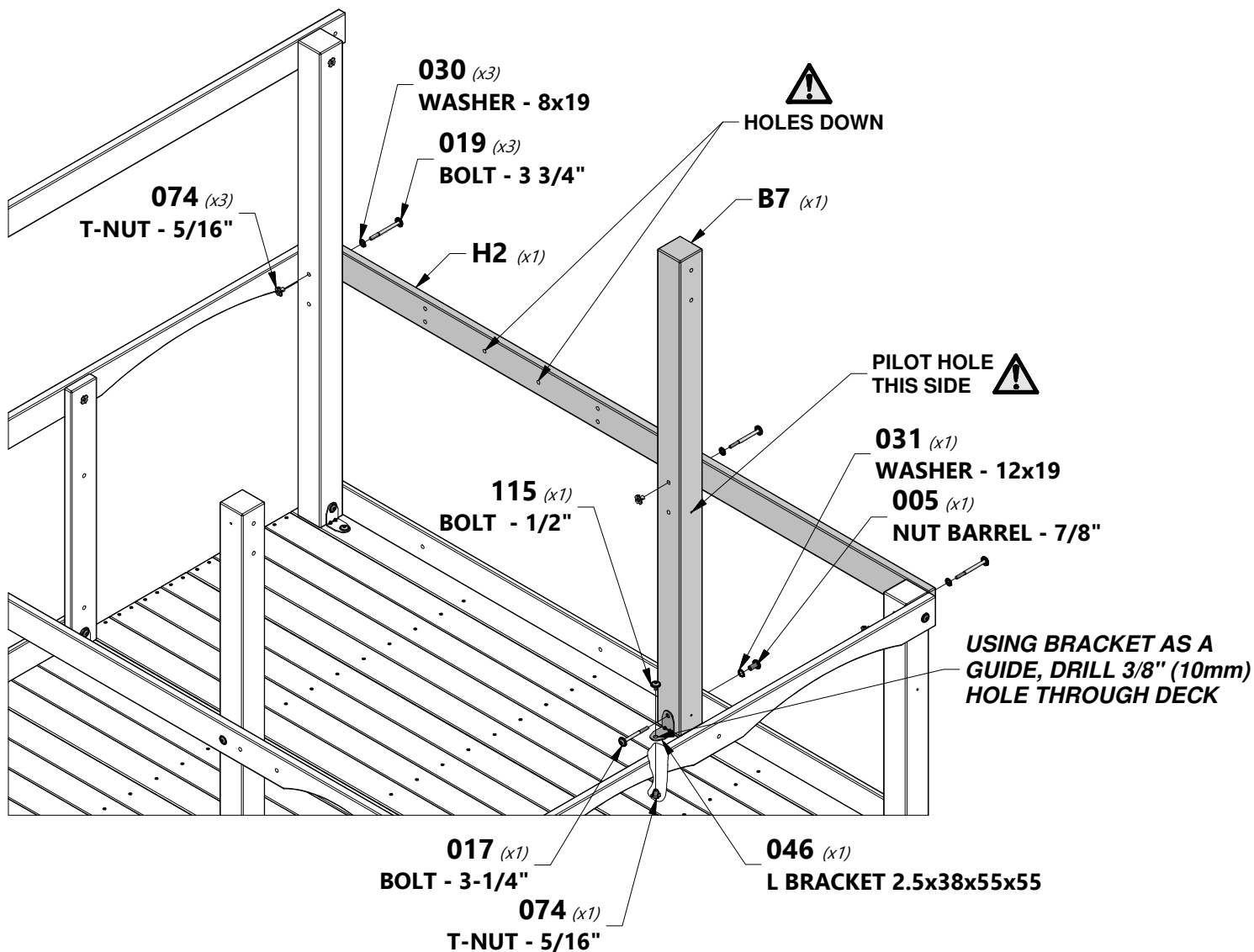

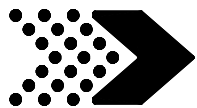

**A100396 | L BRACKET**  
(2) | 51x32x82x3.175

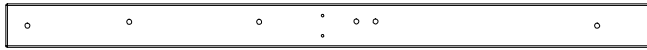

**H9 | FORT WALL BOARD - W4L15916**  
(2) | 1"x3 3/8"x50 1/2" (24x86x1284)

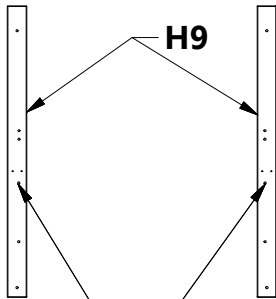

**NOTE:**  
HOLES ARE CLOSER TO THE INSIDE  
WHEN INSTALLED.



**H100044 | BOLT HEX**  
(4) | 5/16x2



**H100030 | WASHER LOCK  
EXT**  
(2) | 8x19



**H100010 | BOLT WH**  
(2) | 5/16x1-1/2



**H100074 | T-NUT**  
(6) | 5/16



**H100095 | WASHER SPLIT**  
(4) | 5/16



**H100105 | WASHER FLAT**  
(4) | 8x27



**TIP:**  
INSTALL T-NUTS INTO  
BOARDS BEFORE ASSEMBLY.

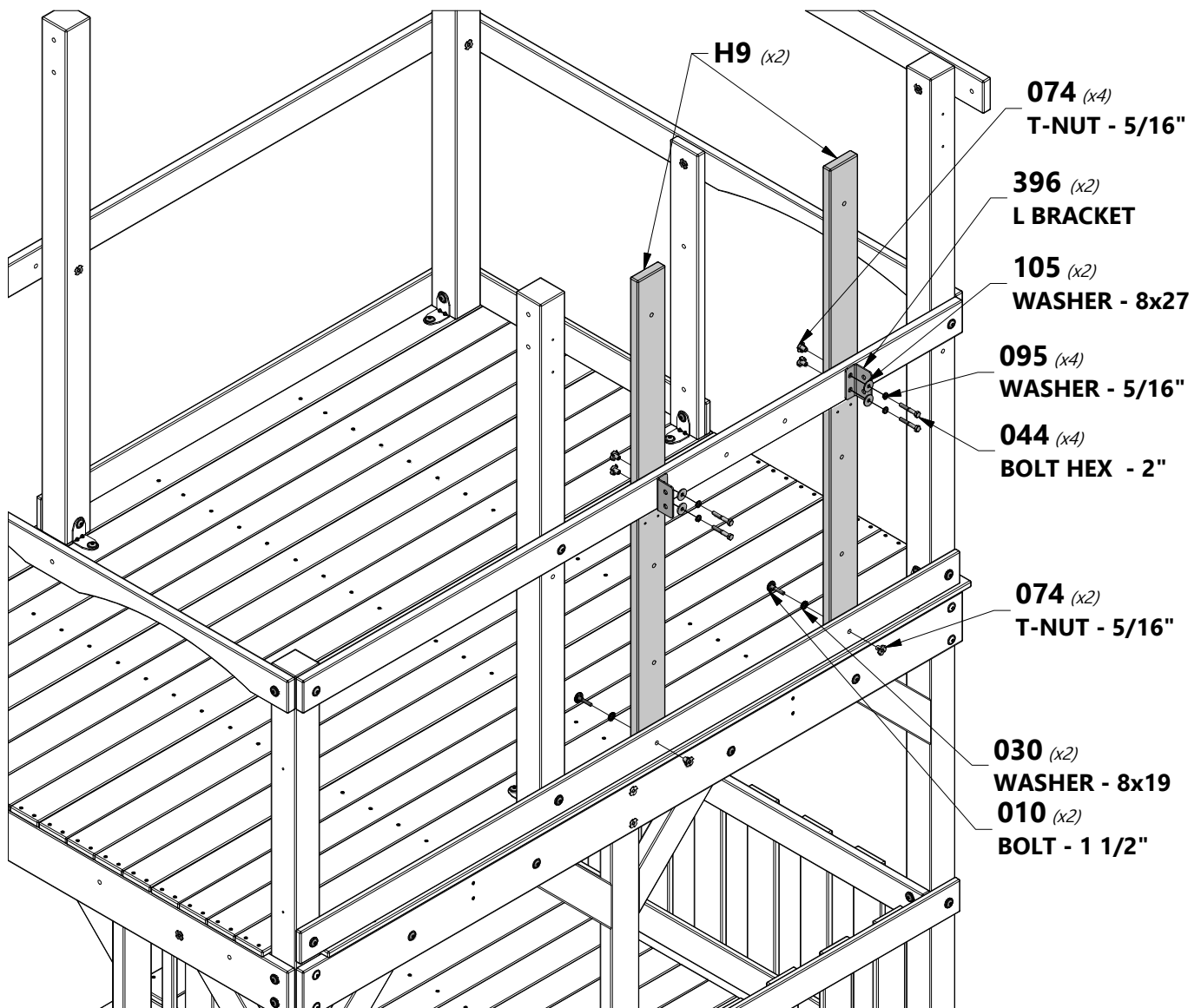

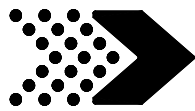

**K5** | CLUB HOUSE WALL RAIL - W4L04626  
(1) | 5/8"x5 1/4"x50 1/4" (16x134x1277)

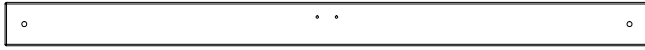

**H14** | SWING BEAM MOUNT - W4L04628  
(1) | 1"x3 3/8"x50 1/4" (24x86x1277)



**H100019** | BOLT WH  
(2) | 5/16x3 3/4

**H100089** | SCREW PFH  
(4) | 8x1 3/4

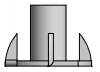

**H100074** | T-NUT  
(4) | 5/16



**H100027** | LAG SCREW WH  
(4) | 5/16x2



**H100010** | BOLT WH  
(2) | 5/16x1-1/2



**H100030** | WASHER LOCK  
(8) | EXT  
8x19

 **TIP:**  
INSTALL T-NUTS INTO  
BOARDS BEFORE ASSEMBLY.

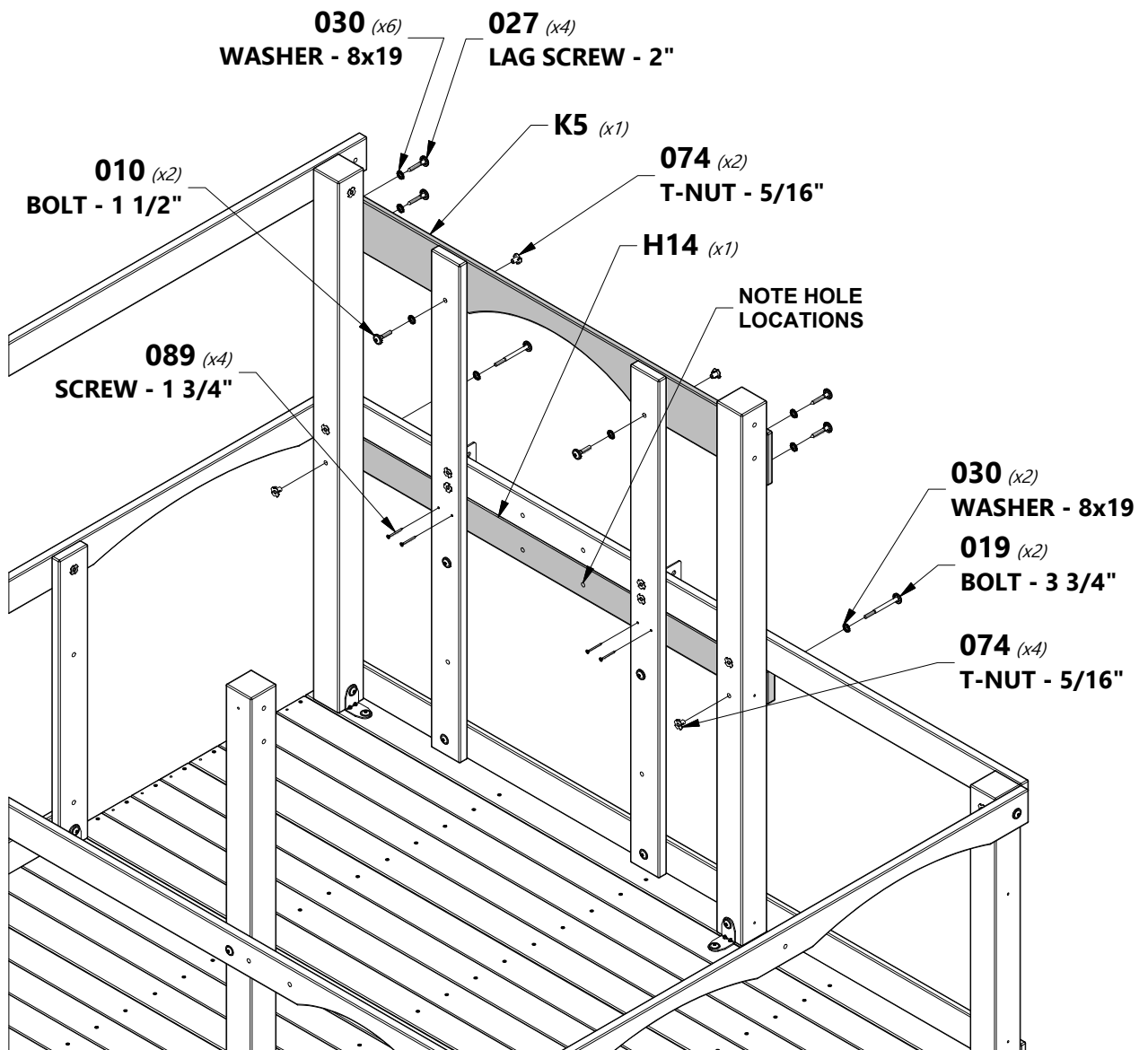



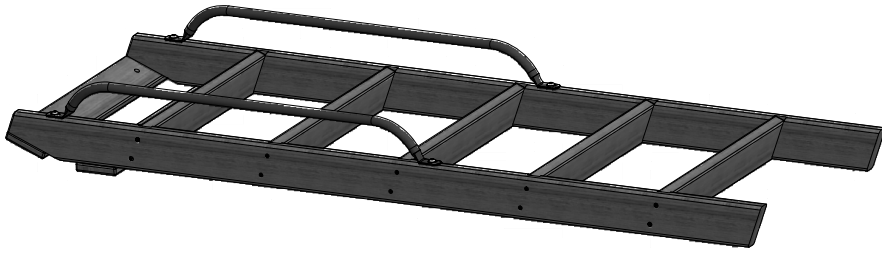
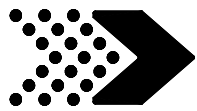

(1) LADDER ASSEMBLY



H100011 | BOLT WH  
(2) | 5/16x1 3/4



H100030 | WASHER LOCK  
(2) | EXT  
8x19

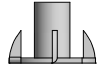

H100074 | T-NUT  
(2) | 5/16

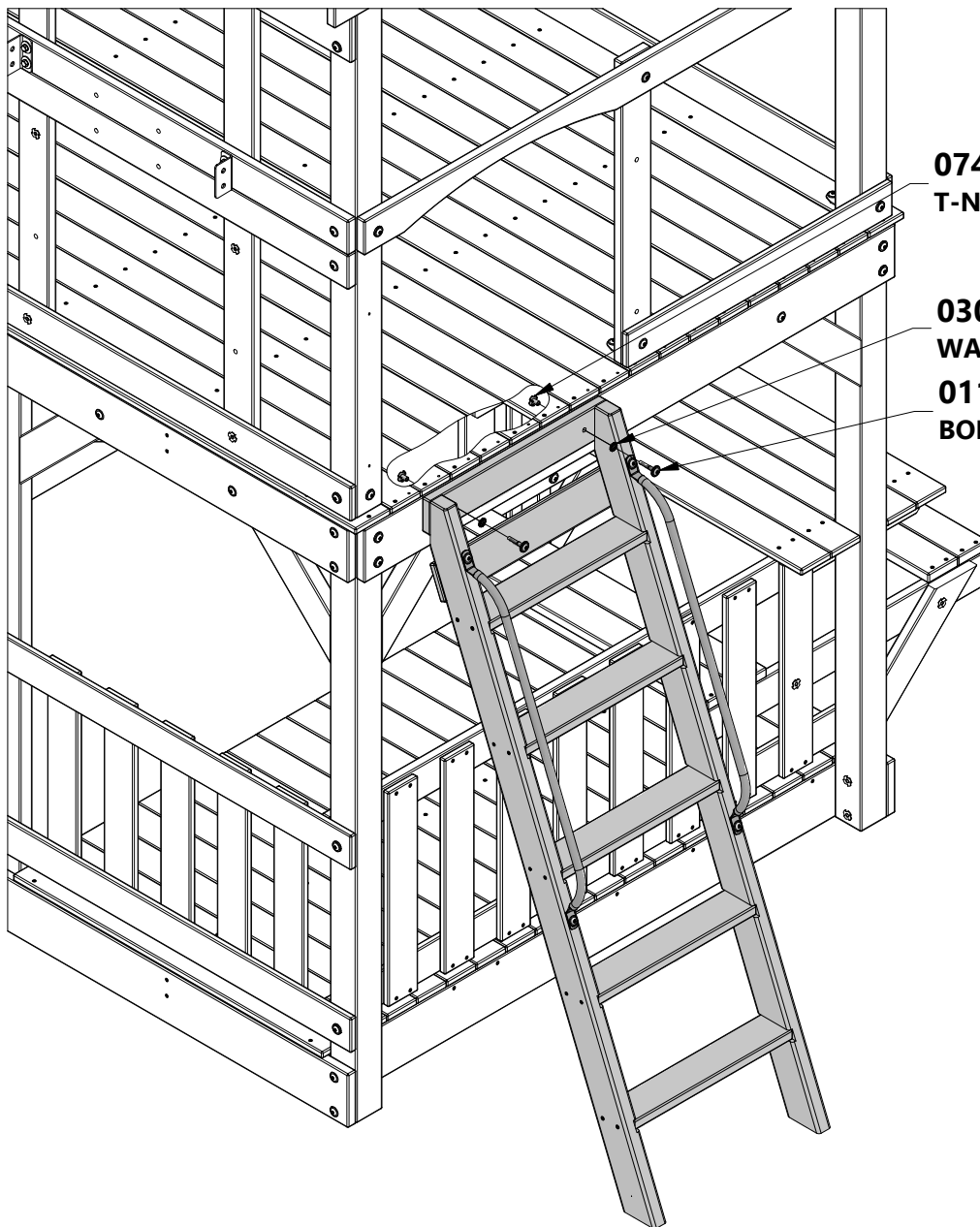

074 (x2)  
T-NUT - 5/16"

030 (x2)  
WASHER - 8x19

011 (x2)  
BOLT - 1 3/4"

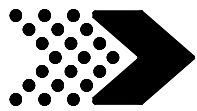

**H4** | ROOF SUPPORT RAIL - W4L04623  
(1) | 1"x3 3/8"x67 1/4" (24x86x1709)



**H100019** | BOLT WH  
(4) | 5/16x3 3/4



**H7** | FRONT CLUB HOUSE WALL RAIL - W4L04625  
(1) | 1"x3 3/8"x60 1/2" (24x86x1537)



**H100074** | T-NUT  
(4) | 5/16



**H100030** | WASHER LOCK  
(4) | EXT  
8x19



**TIP:**  
INSTALL T-NUTS INTO  
BOARDS BEFORE ASSEMBLY.

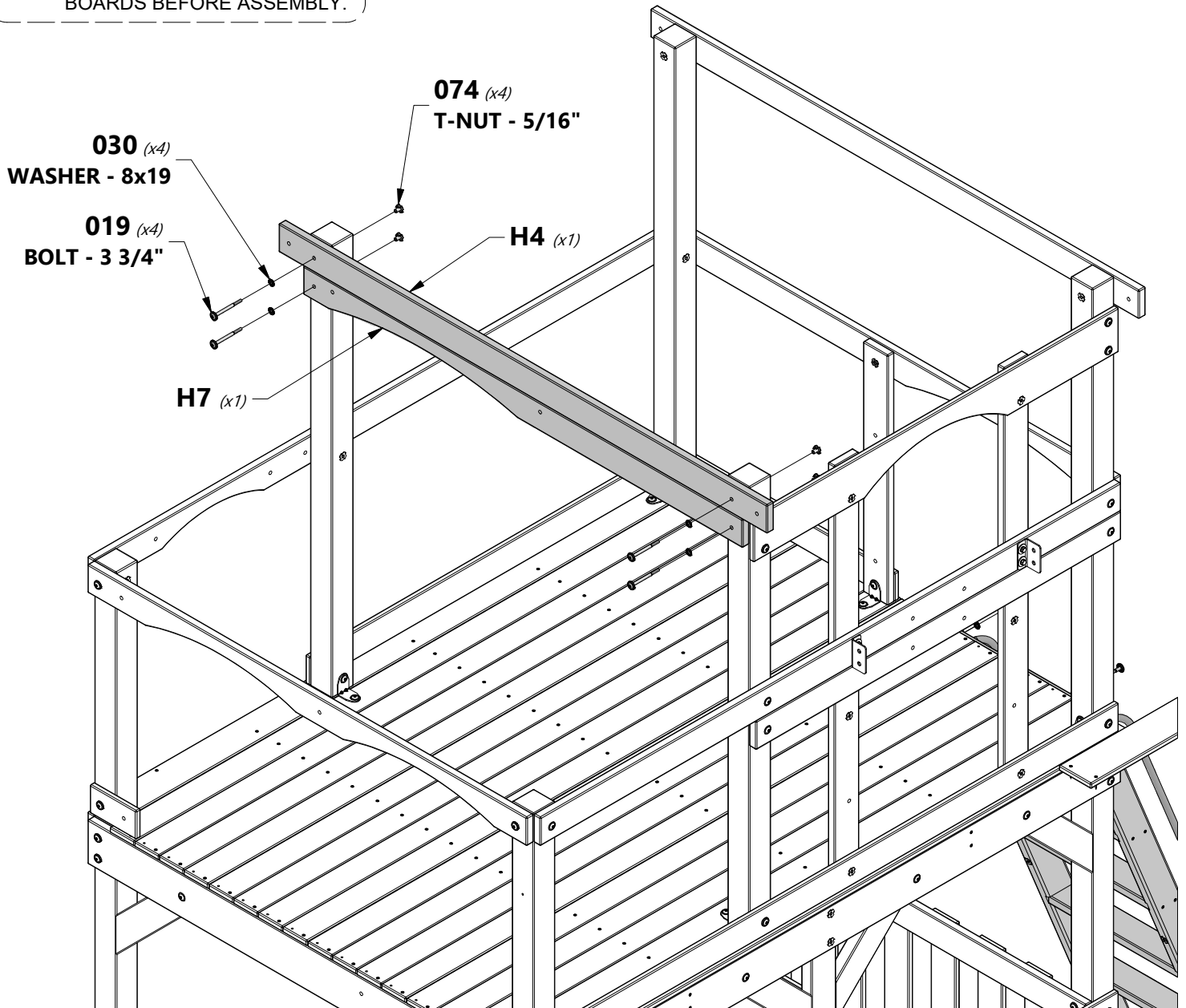



**A4M01046** | L BRACKET  
(1) | 2.5x38x55x55



**H8** | CLUB HOUSE LEG - W4L04637  
(1) | 1"x3 3/8"x50 1/2" (24x86x1284)

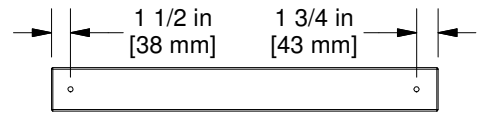

**M21** | CLUB HOUSE WALL RAIL - W4L04613  
(2) | 5/8"x3 3/8"x30 1/4" (16x86x768)



**H100027** | LAG SCREW WH  
(2) | 5/16x2



**H100010** | BOLT WH  
(1) | 5/16x1-1/2

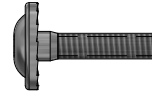

**H100009** | BOLT WH  
(1) | 5/16x1 1/4



**H100115** | BOLT WH  
(1) | 5/16x1/2

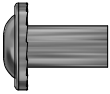

**H100005** | NUT BARREL WH  
(1) | 5/16x7/8



**H100031** | WASHER LOCK  
(1) | EXT  
12x19



**H100030** | WASHER LOCK  
(3) | EXT  
8x19



**H100074** | T-NUT  
(2) | 5/16

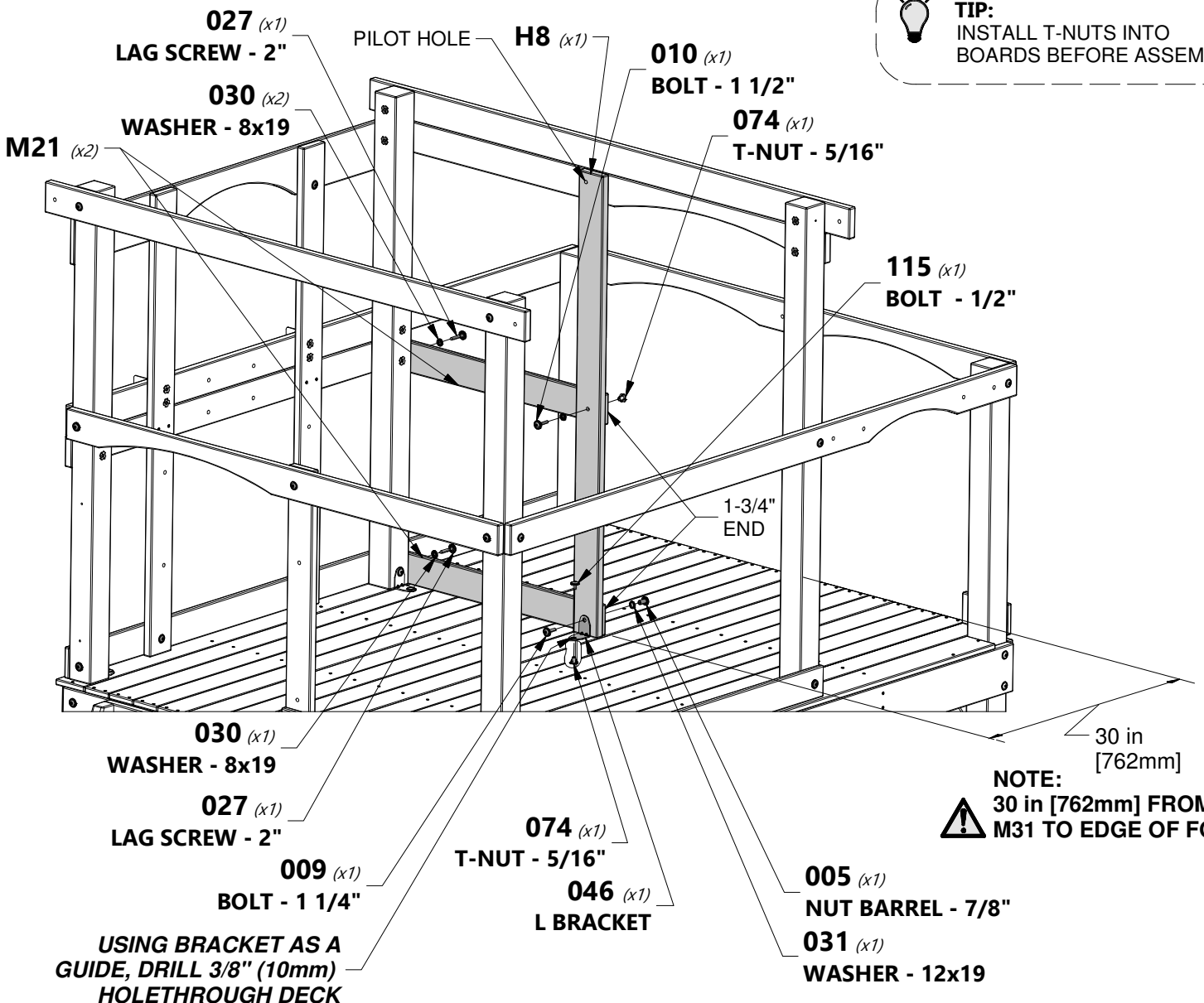

**TIP:** INSTALL T-NUTS INTO BOARDS BEFORE ASSEMBLY.

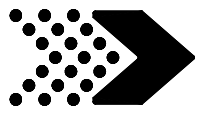

**H13** | CLUB HOUSE WALL RAIL - W4L04624  
(1) | 1"x3 3/8"x50 1/4" (24x86x1277)



**H100027** | LAG SCREW WH  
(2) | 5/16x2



**H100030** | WASHER LOCK  
(2) | EXT  
8x19

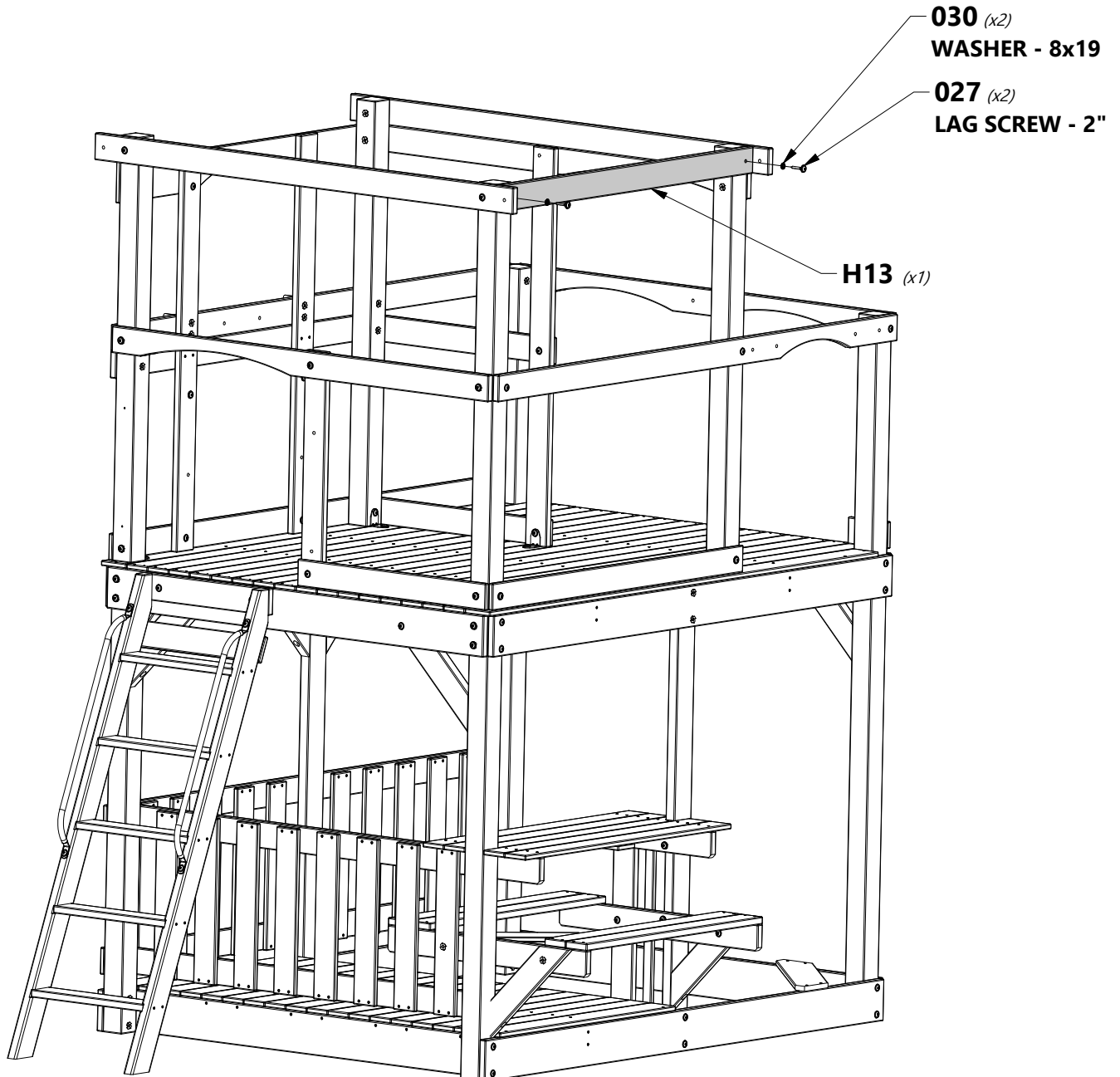

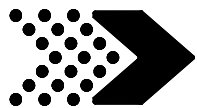

# FORT ASSEMBLY

# STEP 33



**A4M01046** | L BRACKET  
(1) | 2.5x38x55x55

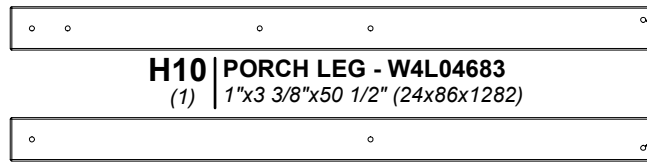

**H10** | PORCH LEG - W4L04683  
(1) | 1"x3 3/8"x50 1/2" (24x86x1282)



**H11** | PORCH LEG - W4L04610  
(1) | 1"x3 3/8"x50 1/2" (24x86x1282)

**NOTE:**  
HOLES GO OUTWARD  
WHEN INSTALLED.



**H100011** | BOLT WH  
(2) | 5/16x1 3/4



**H100010** | BOLT WH  
(1) | 5/16x1-1/2



**H100115** | BOLT WH  
(2) | 5/16x1/2



**H100005** | NUT BARREL WH  
(1) | 5/16x7/8



**H100030** | WASHER LOCK  
(3) | EXT  
8x19



**H100031** | WASHER LOCK  
(1) | EXT  
12x19



**H100074** | T-NUT  
(4) | 5/16



**TIP:**  
INSTALL T-NUTS INTO  
BOARDS BEFORE ASSEMBLY.

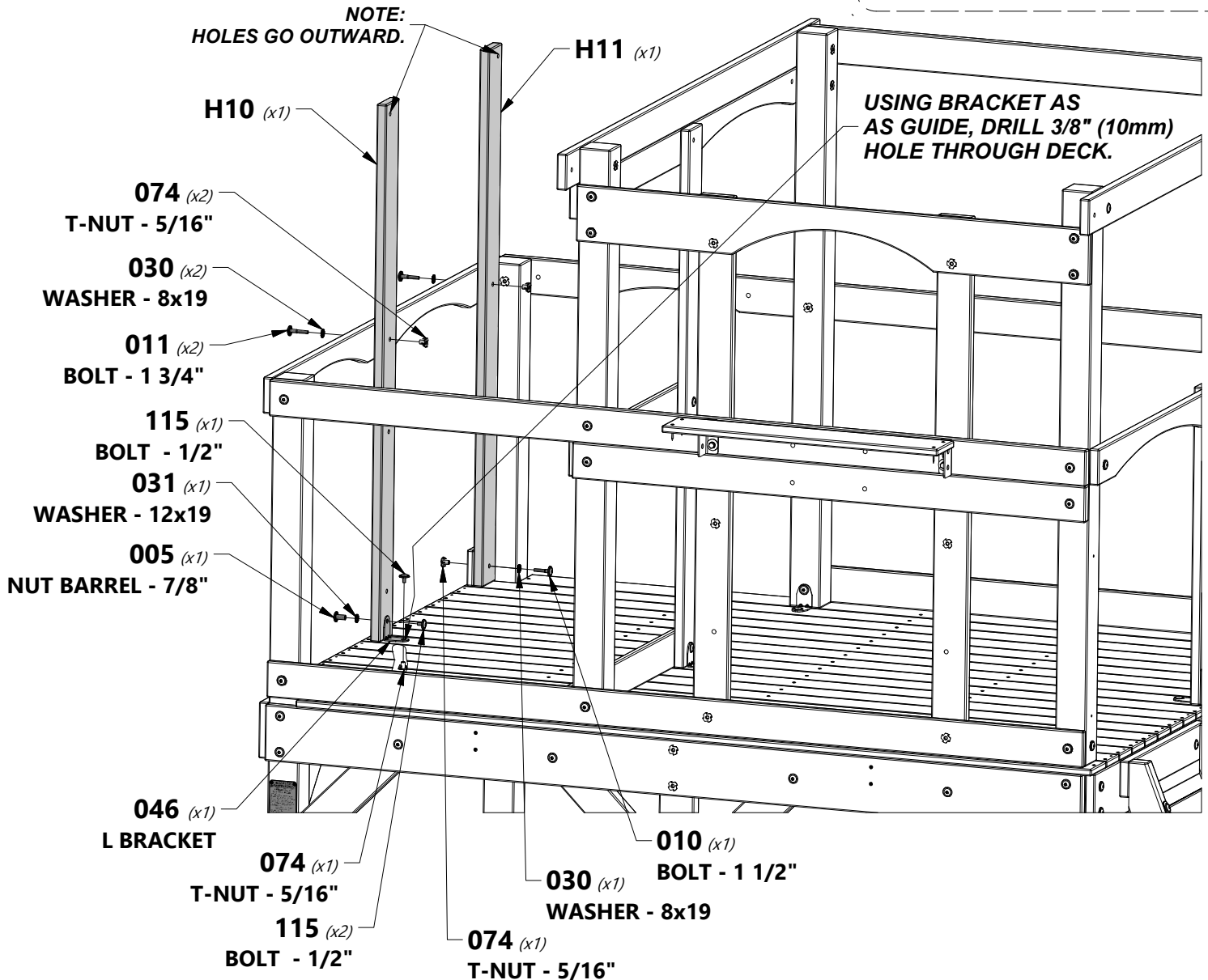

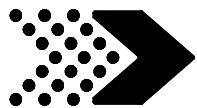

**H100088 | SCREW PFH**  
(56) | 8x1 1/8



**M8 | CLUB HOUSE WALL BOARD - W4L04630**  
(2) | 5/8"x3 3/8"x50 1/2" (16x86x1284)

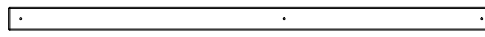

**N1 | CLUB HOUSE WALL BOARD - W4L04629**  
(2) | 5/8"x2 3/8"x50 1/2" (16x60x1284)



**M9 | CLUB HOUSE WALL BOARD - W4L04631**  
(2) | 5/8"x3"x50 1/2" (16x76x1284)

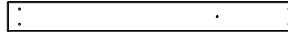

**M23 | CLUB HOUSE WALL BOARD - W4L04634**  
(2) | 5/8"x3 1/8"x29 7/8" (16x80x758)



**M22 | CLUB HOUSE WALL BOARD - W4L04633**  
(4) | 5/8"x3 3/8"x29 7/8" (16x86x758)

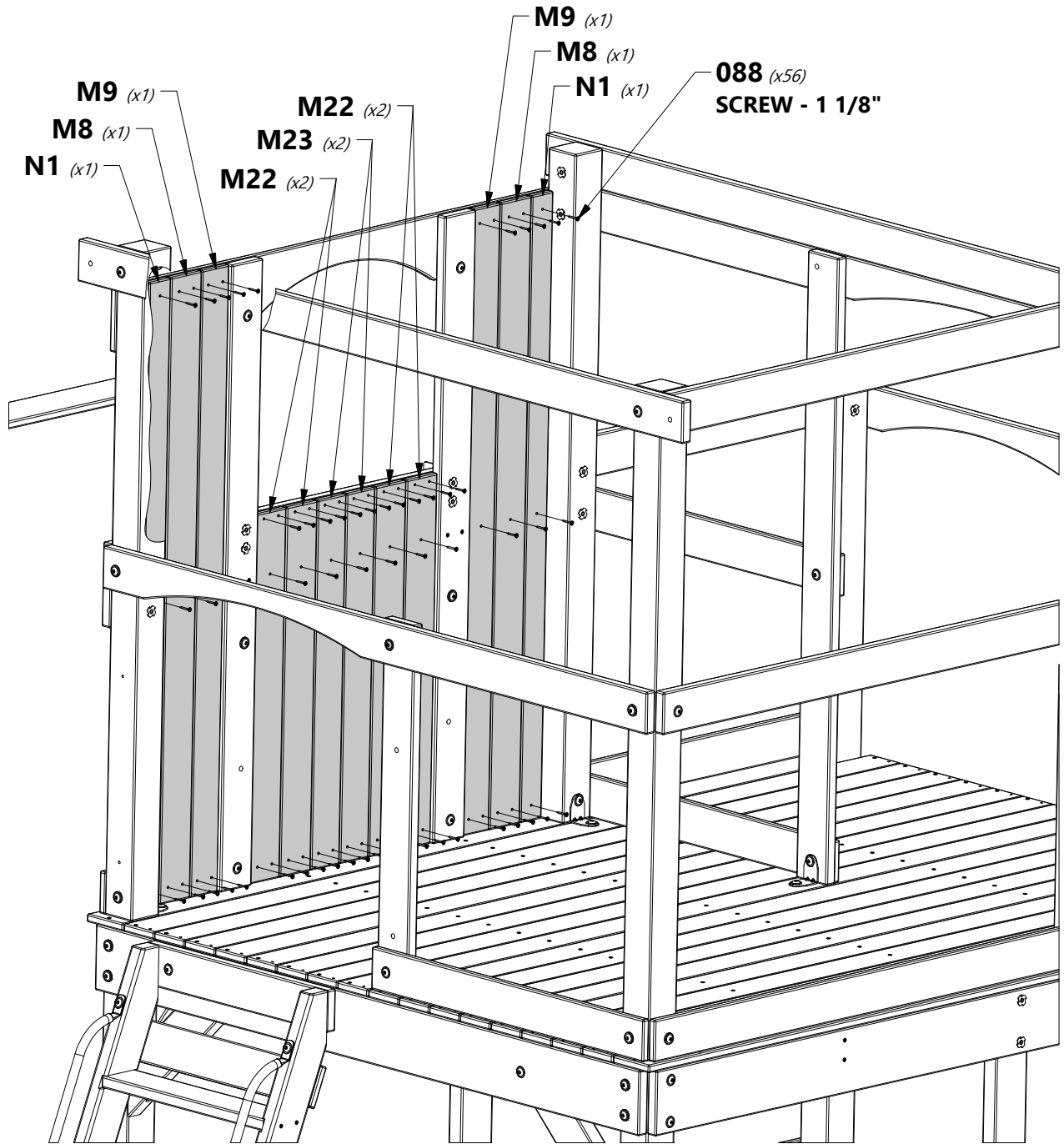

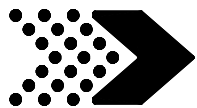

**M26** | WALL BOARD - W4L04636  
(2) | 5/8"x3 3/8"x26 1/8" (16x86x664)



**M24** | WALL BOARD - W4L04632  
(6) | 5/8"x3 3/8"x29 7/8" (16x86x758)



**M6** | CLUB HOUSE WALL BOARD - W4L04635  
(1) | 5/8"x3 3/8"x53 7/8" (16x86x1370)



**H100088** | SCREW PFH  
(38) | 8x1 1/8

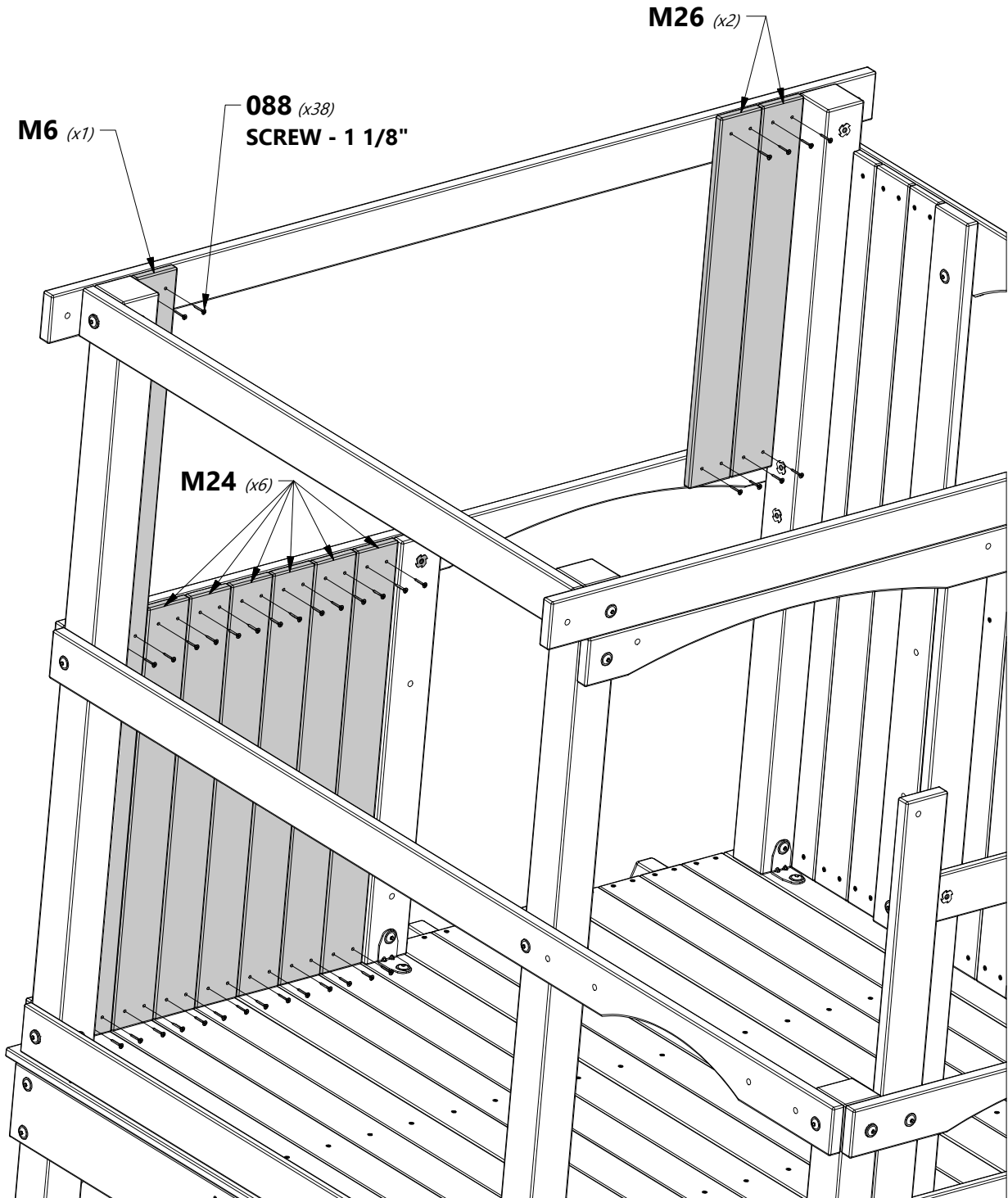

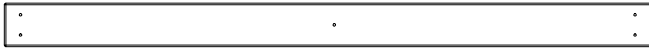
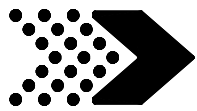

**M8** | FORT WALL BOARD - W4L15914  
(5) | 5/8"x3 3/8"x50 1/2" (16x86x1284)



**M33** | FRONT WINDOW WALL BOARD - W4L04638  
(2) | 5/8"x3 3/8"x6 3/8" (16x86x162)



**M17** | FRONT WINDOW WALL BOARD - W4L04639  
(2) | 5/8"x3 3/8"x35" (16x86x889)



**H100088** | SCREW PFH  
(35) | 8x1 1/8"

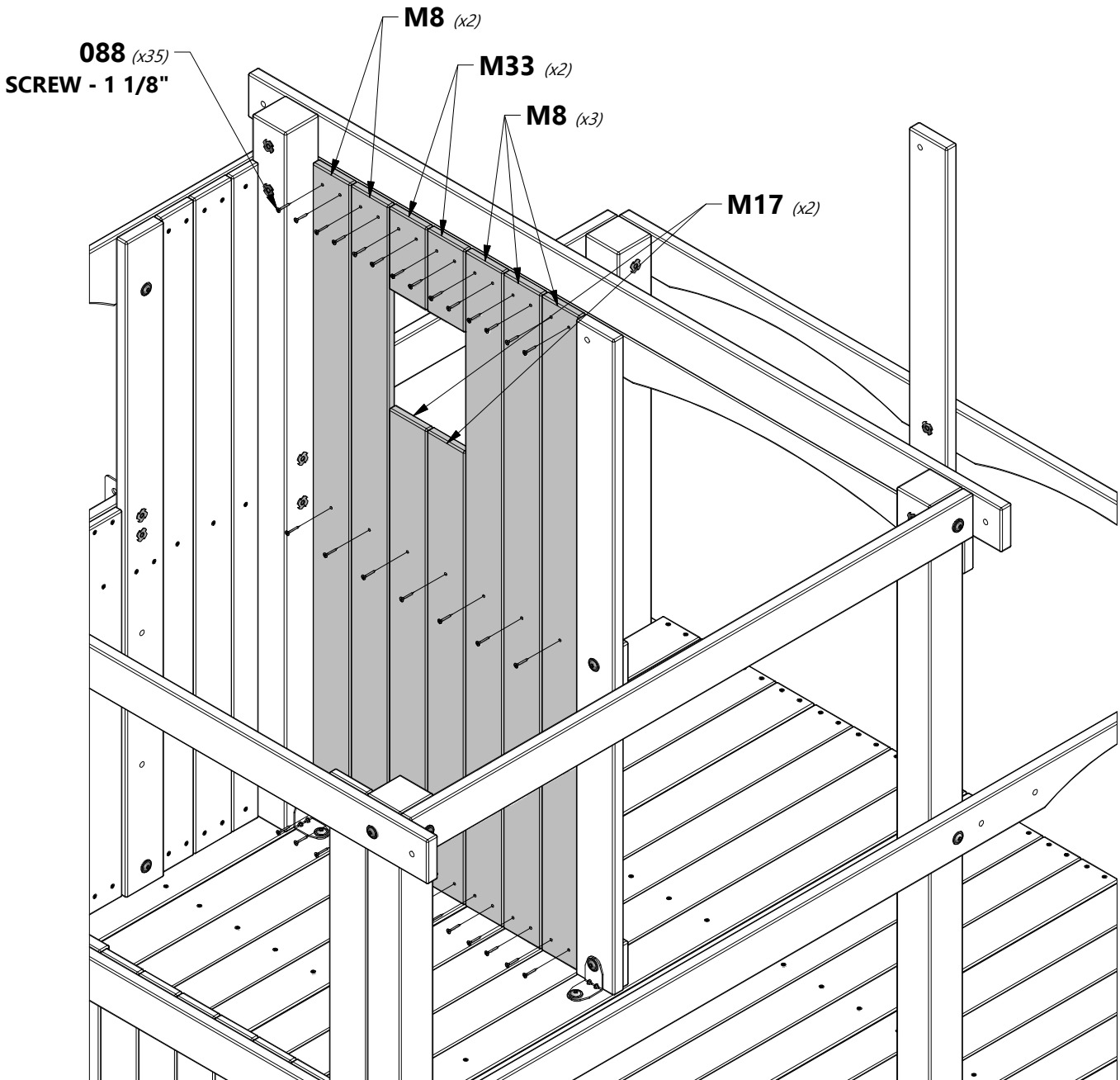



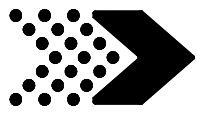

**M24** | WALL BOARD - W4L04632  
(13) | 5/8"x3 3/8"x29 7/8" (16x86x758)



**H100088** | SCREW PFH  
(52) | 8x1 1/8

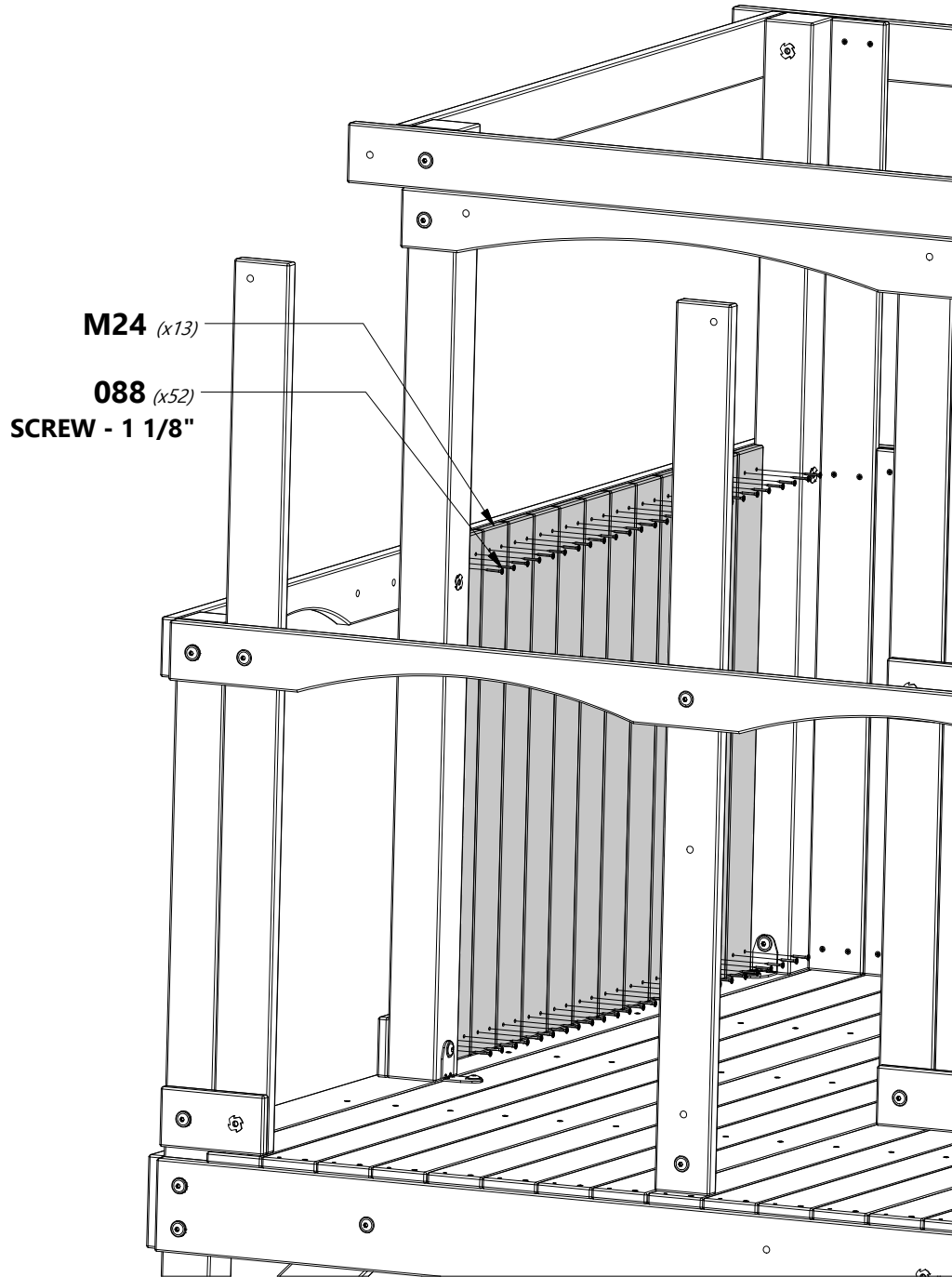

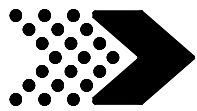

**M15 | WALL BOARD - W4L15943**  
(4) 5/8"x3 3/8"x29 7/8" (16x86x758)



**H100088 | SCREW PFH**  
(16) 8x1 1/8

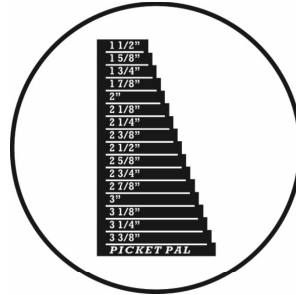

2 5/8 in  
EQUAL SPACING

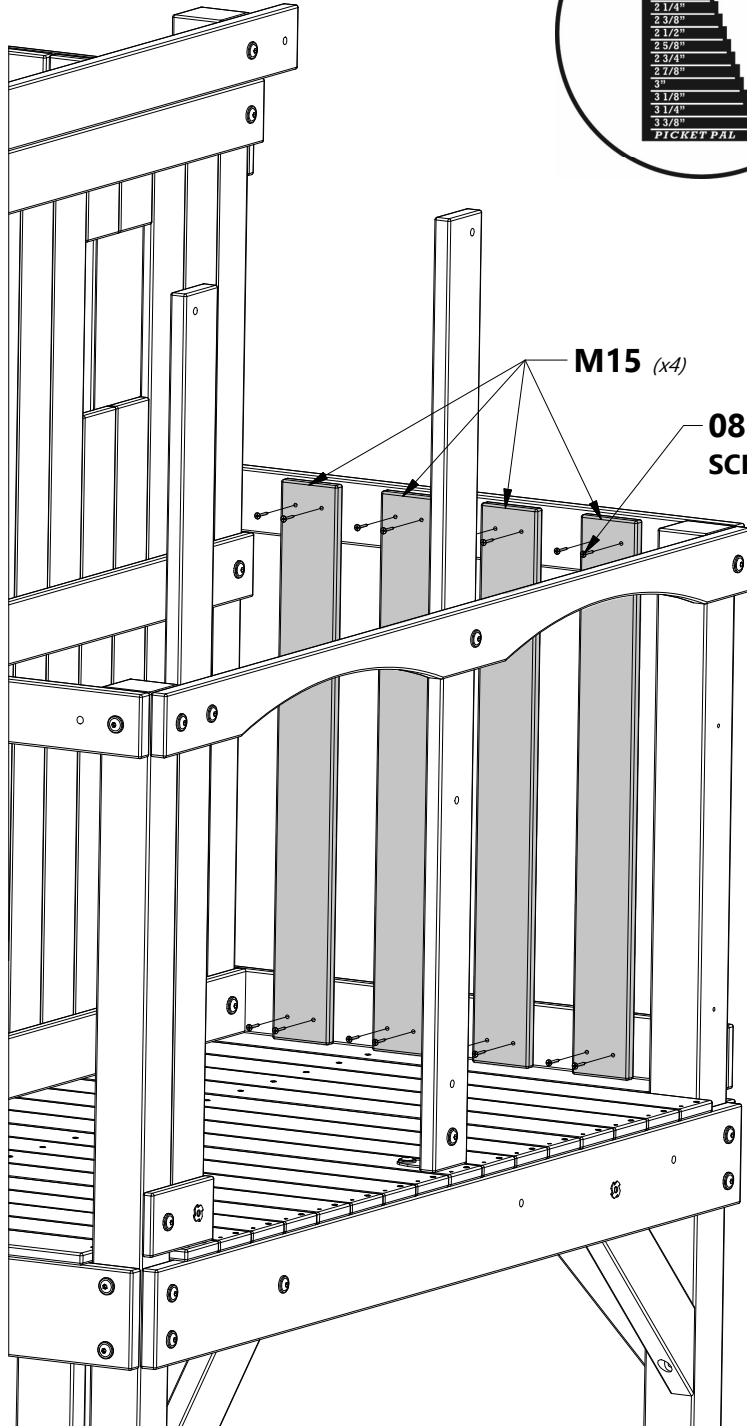
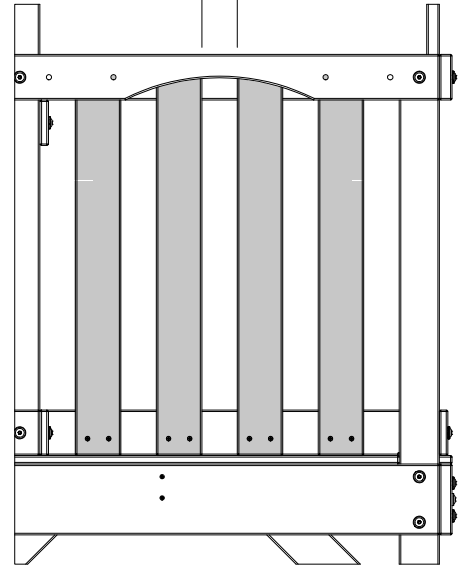

**M15 (x4)**

**088 (x16)**  
**SCREW - 1 1/8"**

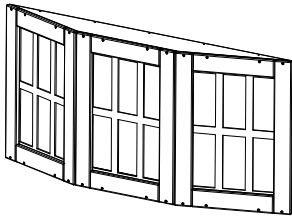
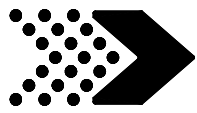

(2) BAY WINDOW ASSEMBLY



H100111 | SCREW PFH  
(20) | 8x2



H100128 | SCREW PWH  
(24) | 8x5/8

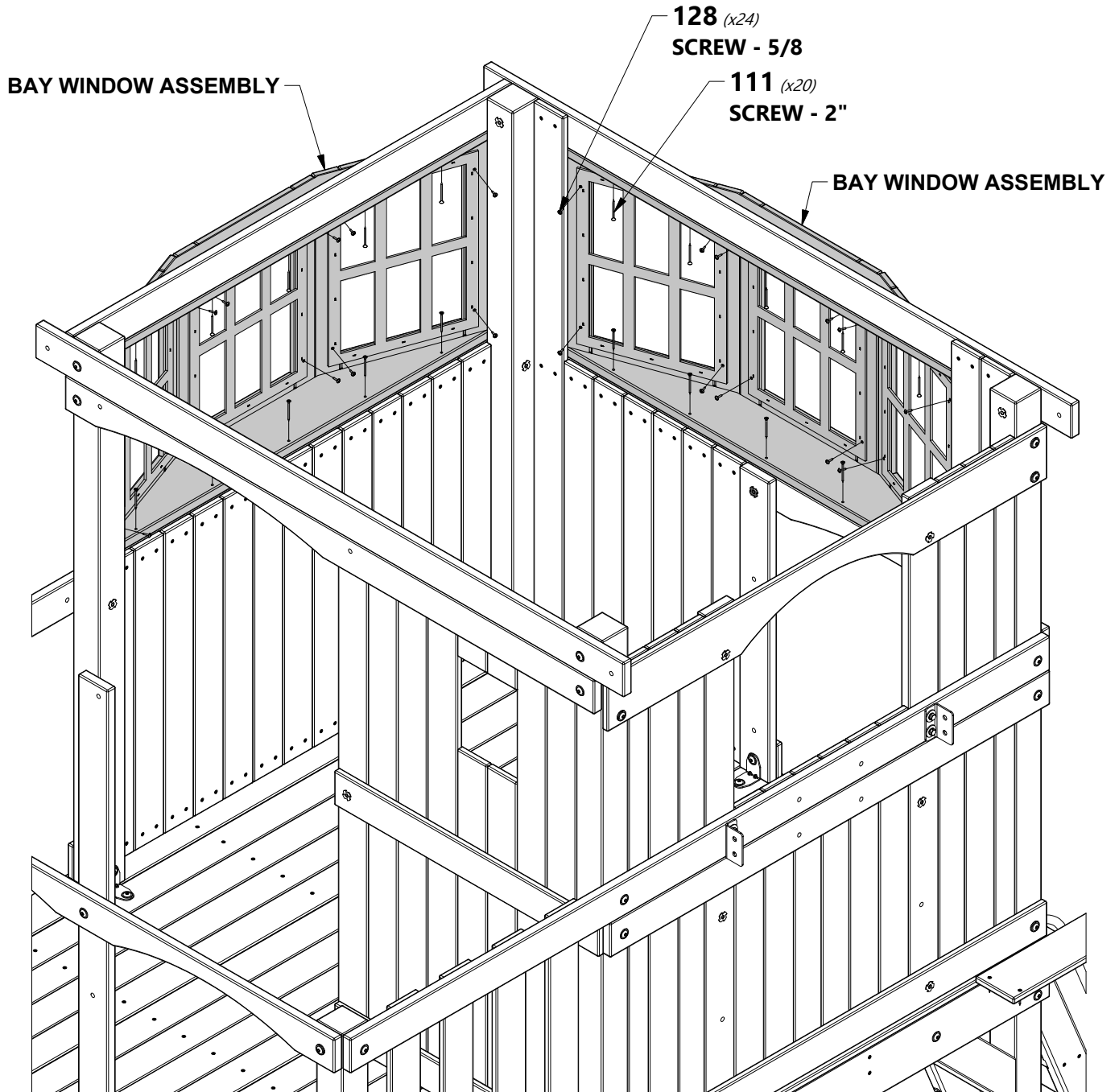

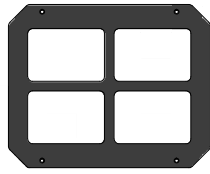
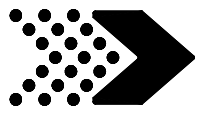

**A100146** | WINDOW  
(1) | 216x267 GREEN



**H100070** | SCREW PWH  
(4) | 8x3/4

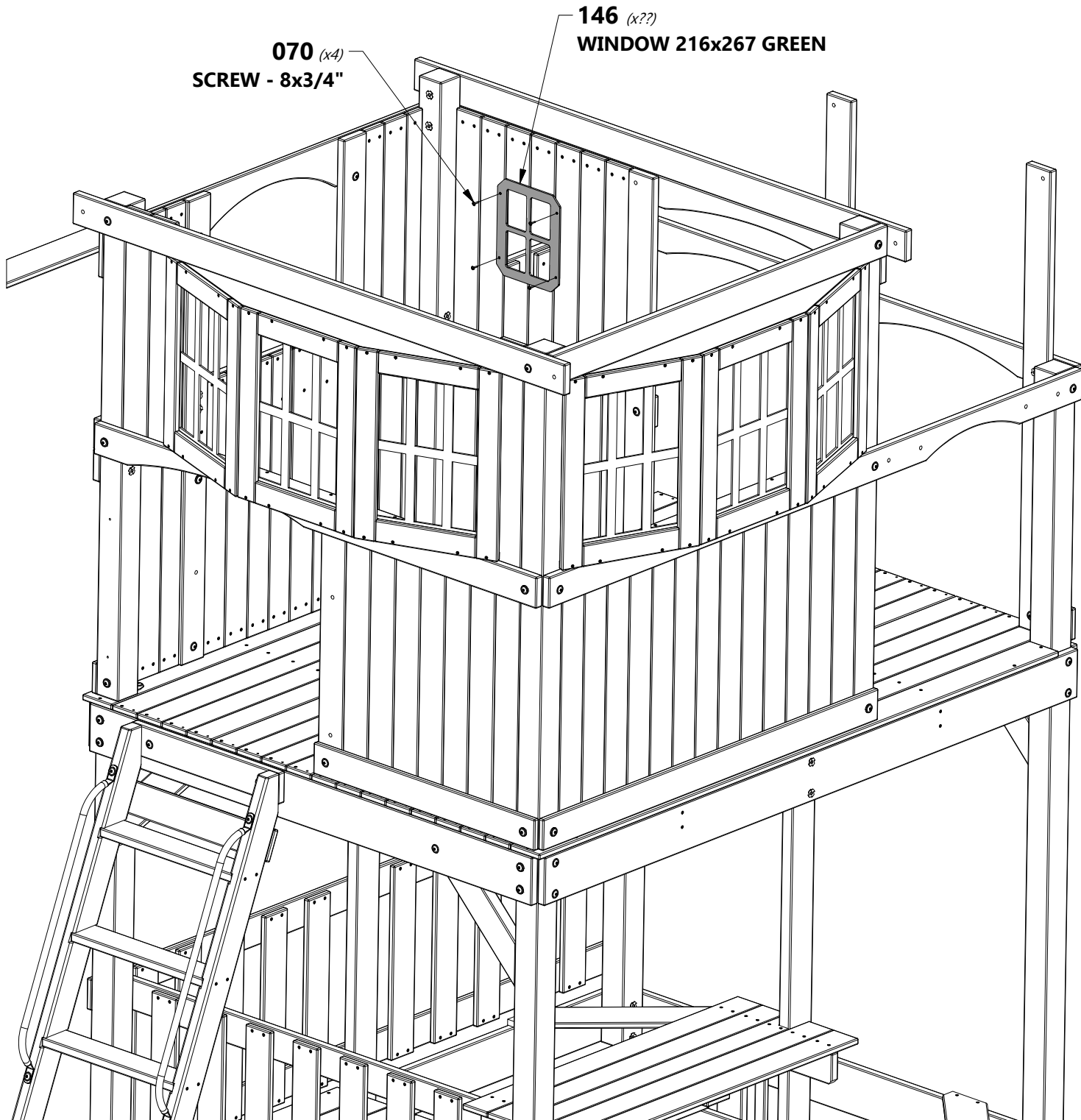

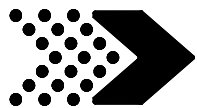

**A100324** | LADDER RUNG  
(2) | 578 GREEN



**H100008** | BOLT WH  
(4) | 5/16x1

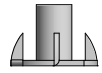

**H100074** | T-NUT  
(4) | 5/16



**TIP:**  
INSTALL T-NUTS INTO  
BOARDS BEFORE ASSEMBLY.

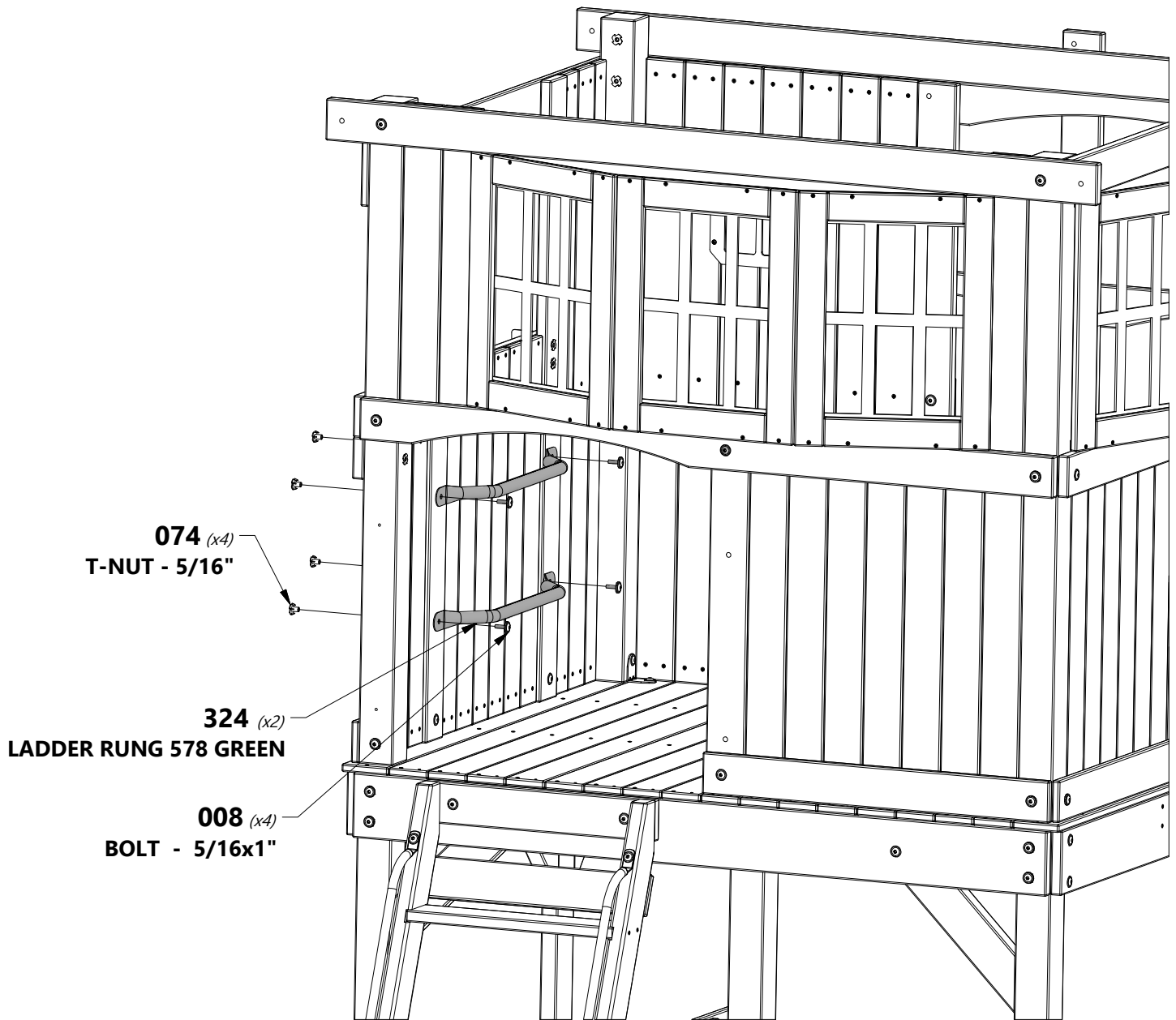

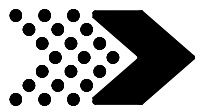

**H12** | ROOF RAFTER - W4L04640  
(4) | 1"x3 3/8"x50 3/8" (24x86x1278)



**H100011** | BOLT WH  
(4) | 5/16x1 3/4



**H100030** | WASHER LOCK  
(4) | EXT  
8x19



**H100091** | SCREW PFH  
(2) | 8X2 1/4

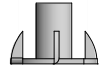

**H100074** | T-NUT  
(4) | 5/16



**TIP:**  
INSTALL T-NUTS INTO  
BOARDS BEFORE ASSEMBLY.

USING A 3/16" DRILL BIT, MARK AND DRILL A PILOT  
HOLE INTO 'H12' RAFTER TO PREVENT SPLITTING.  
ONLY DRILL THROUGH ONE RAFTER NOT BOTH.

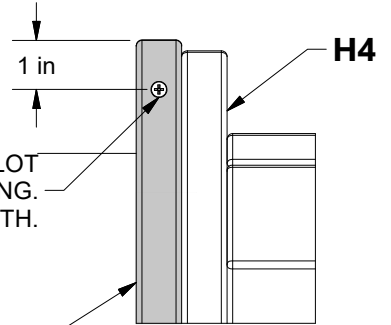

**H12** (x4)

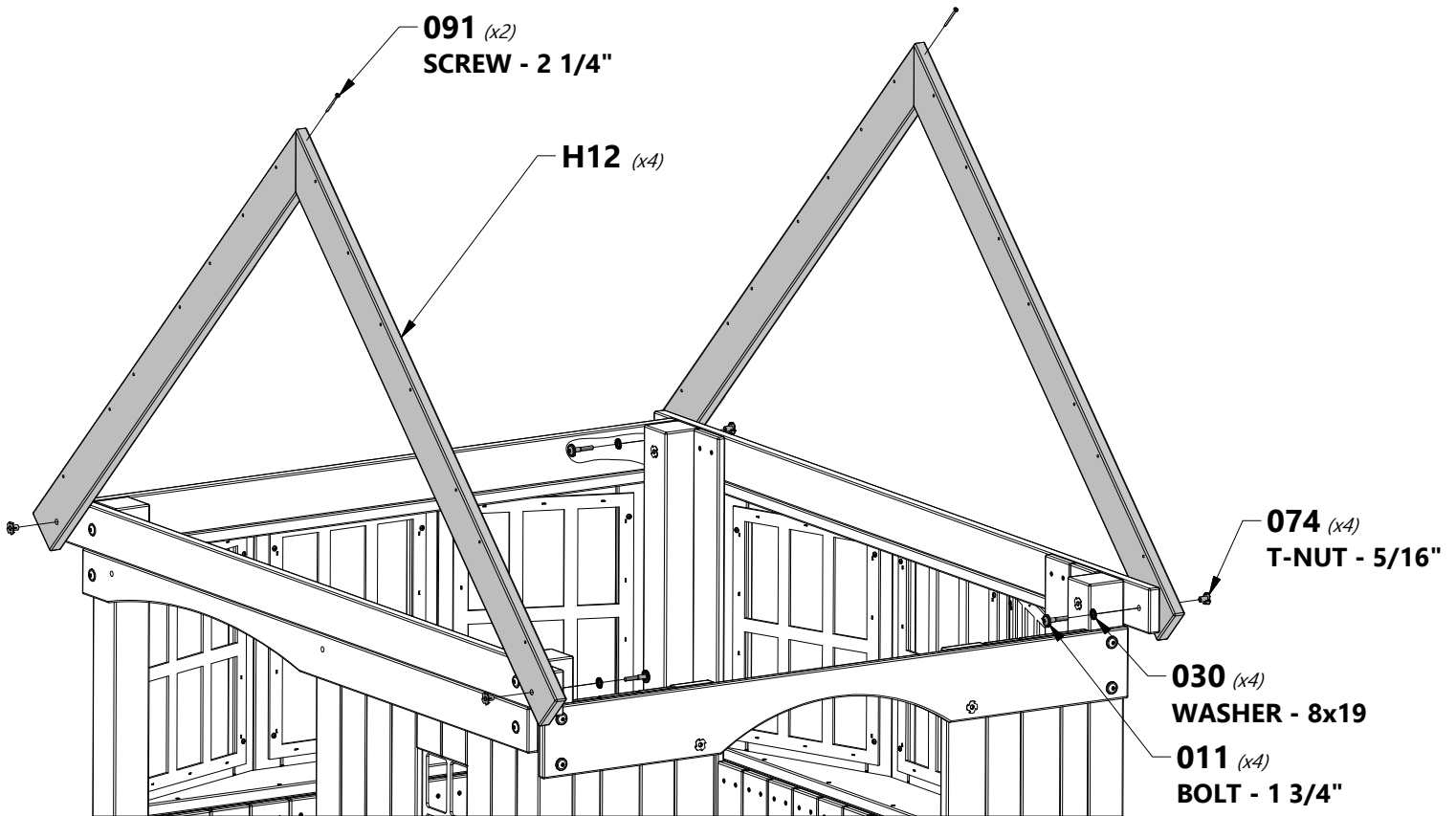

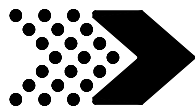

**M5** | GABLE BOARD - W4L04641  
(2) | 5/8"x3 3/8"x59 1/2" (16x86x1510)



**M7** | GABLE BOARD - W4L04642  
(2) | 5/8"x3 3/8"x52 5/8" (16x86x1338)



**H100088** | SCREW PFH  
(8) | 8x1 1/8

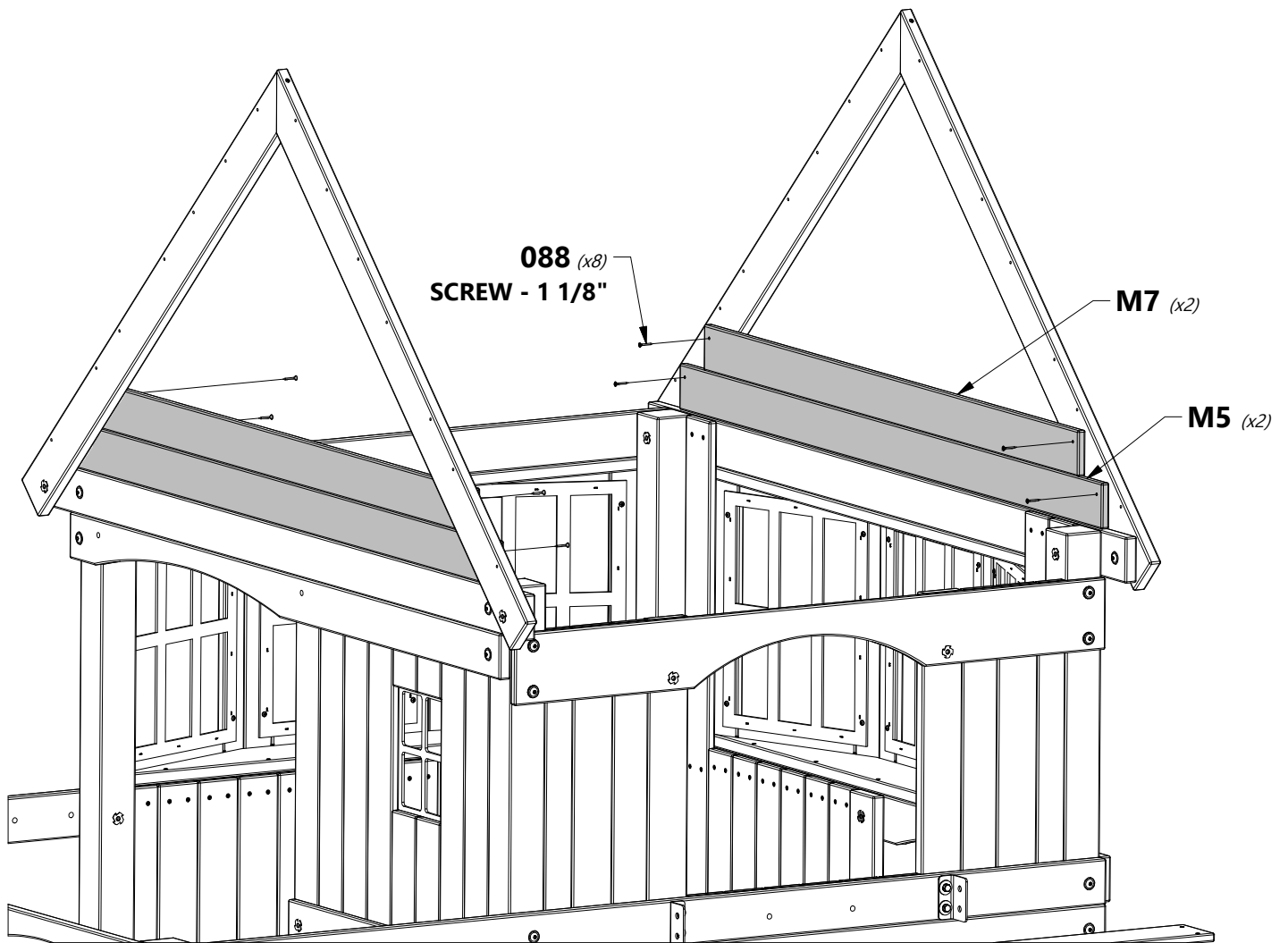

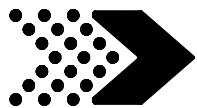

**N6** | WINDOW TRIM - W4L04646  
 (2) | 5/8"x2 3/8"x12 1/4" (16x60x310)

**M29** | GABLE WINDOW BOARD - W4L04643  
 (2) | 5/8"x3 3/8"x16 1/8" (16x86x410)

**M31** | GABLE WINDOW BOARD - W4L04644  
 (2) | 5/8"x3 3/8"x12 3/4" (16x86x324)

**H100088** | SCREW PFH  
 (18) | 8x1 1/8

**N10** | GABLE BOARD - W4L04645  
 (1) | 5/8"x2 3/8"x27 5/8" (16x60x702)

**M28** | GABLE WINDOW BOARD - W4L04647  
 (2) | 5/8"x3 3/8"x19 1/2" (16x86x496)

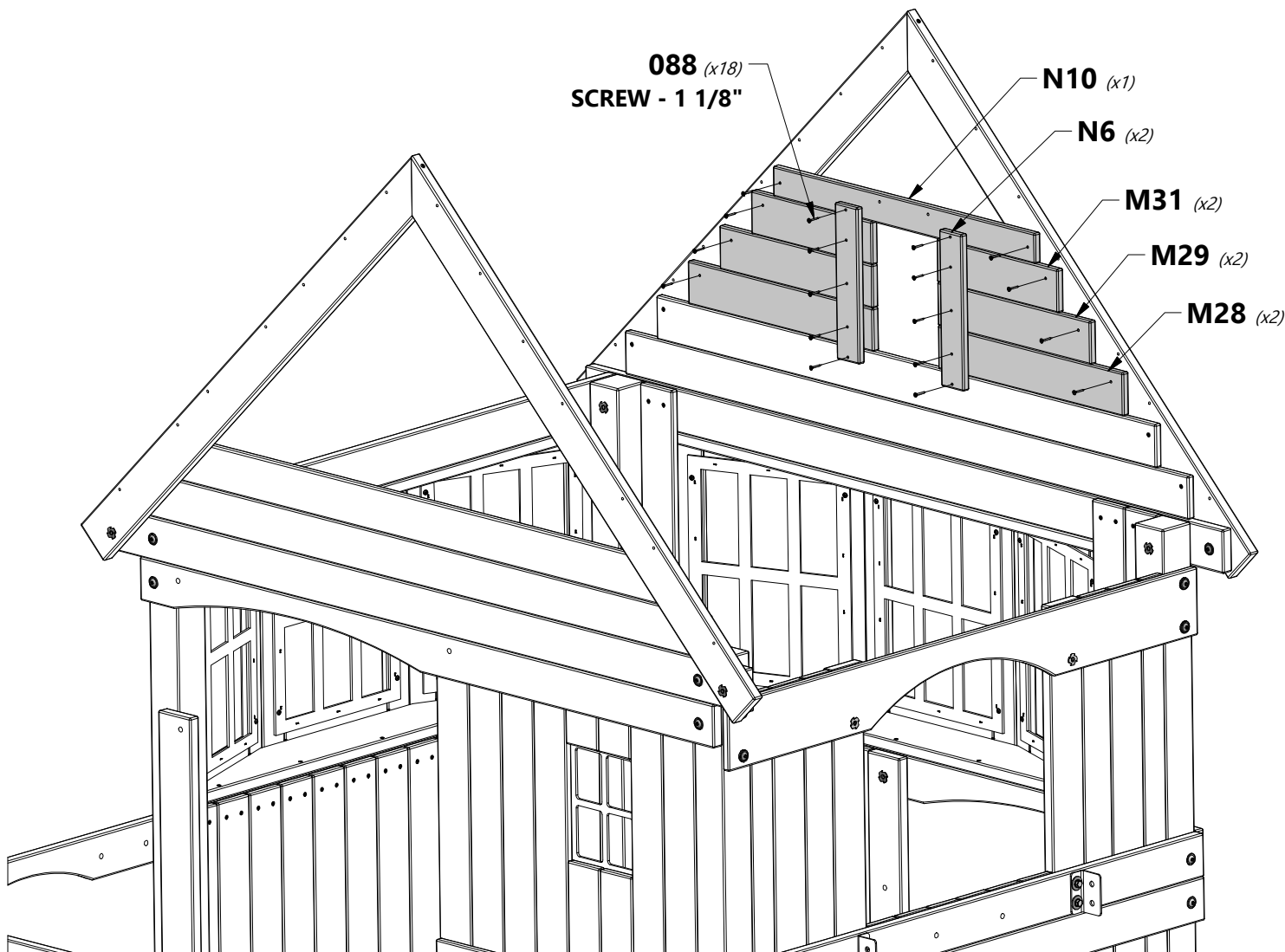
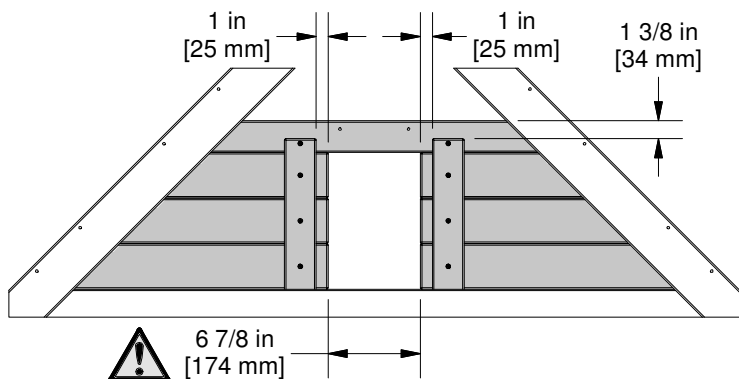





**N10** | GABLE BOARD - W4L04645  
 (1) | 5/8"x2 3/8"x27 5/8" (16x60x702)

**M14** | GABLE BOARD - W4L04651  
 (1) | 5/8"x3 3/8"x39 1/8" (16x86x994)

**M18** | GABLE BOARD - W4L04652  
 (1) | 5/8"x3 3/8"x32 3/8" (16x86x822)

**M12** | GABLE BOARD - W4L04650  
 (1) | 5/8"x3 3/8"x45 7/8" (16x86x1166)

 **H100088** | SCREW PFH  
 (8) | 8x1 1/8

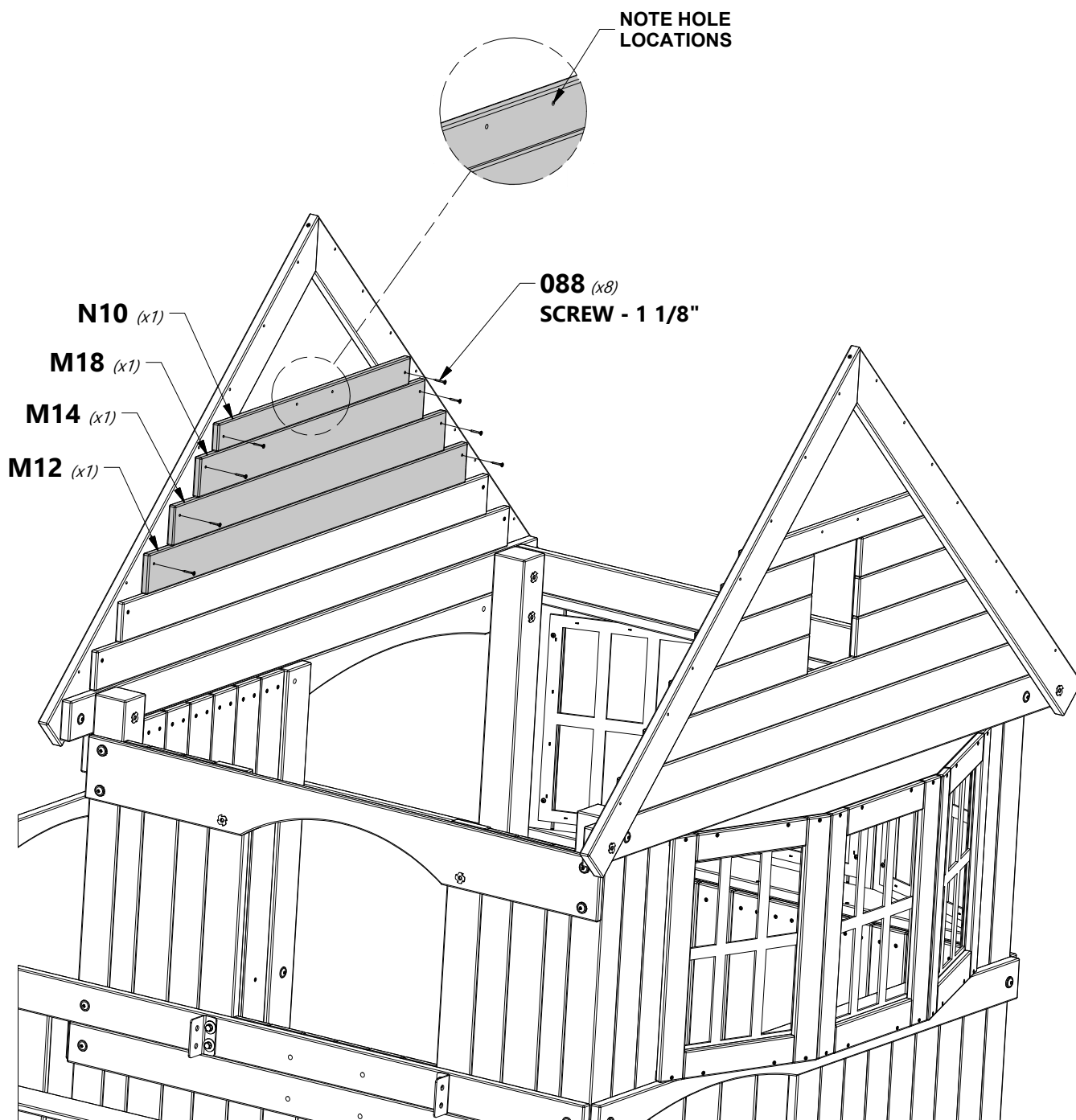

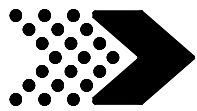

**N7** | GABLE TRIM - W4L04648  
(2) | 5/8"x2 3/8"x11 1/2" (16x60x292)



**N9** | GABLE TRIM - W4L04649  
(4) | 5/8"x2 3/8"x6 1/2" (16x60x165)

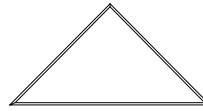

**K6** | TRIANGLE SUNBURST - W4L04827  
(2) | 5/8"x5 1/4"x10 3/8" (16x134x265)



**H100088** | SCREW PFH  
(22) | 8x1 1/8

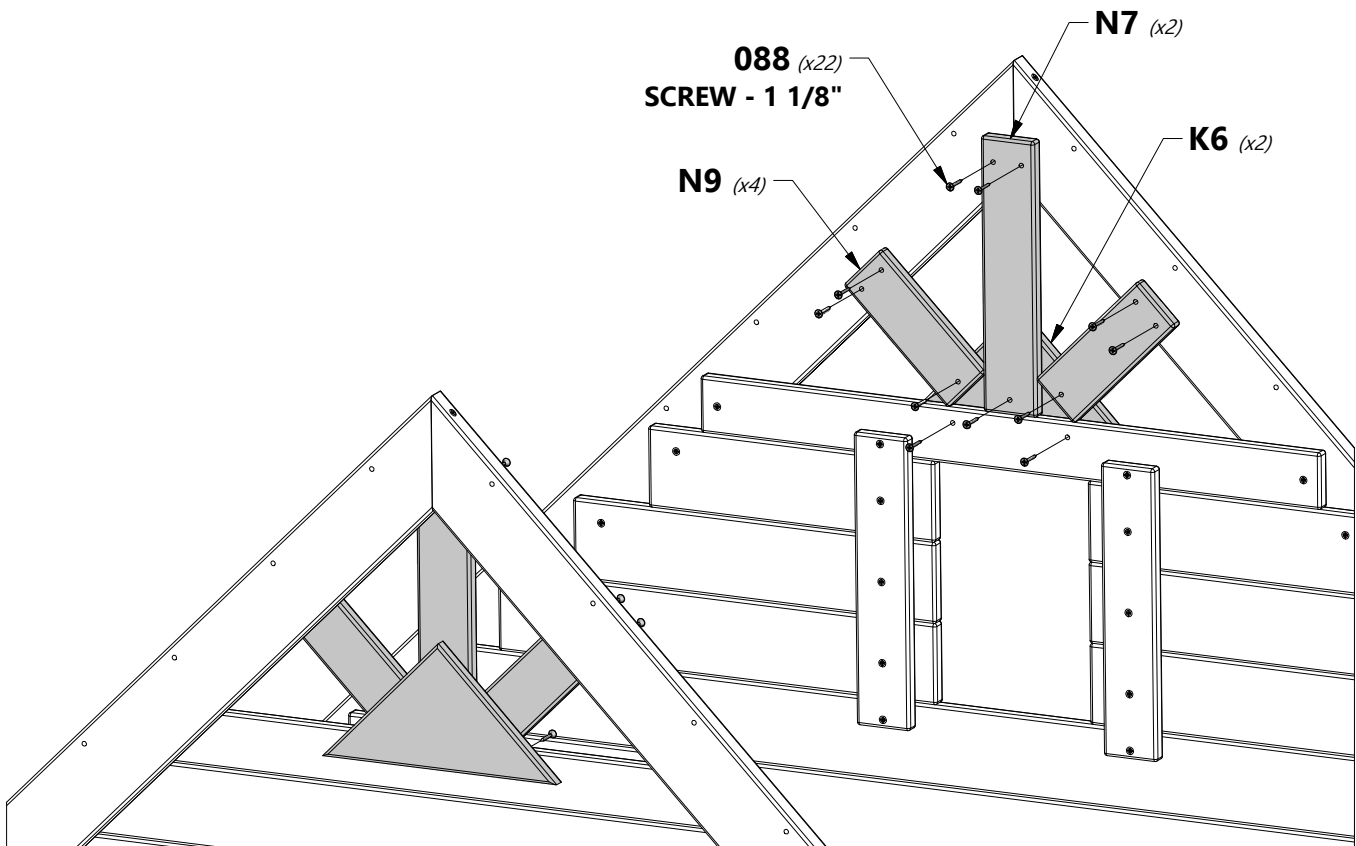
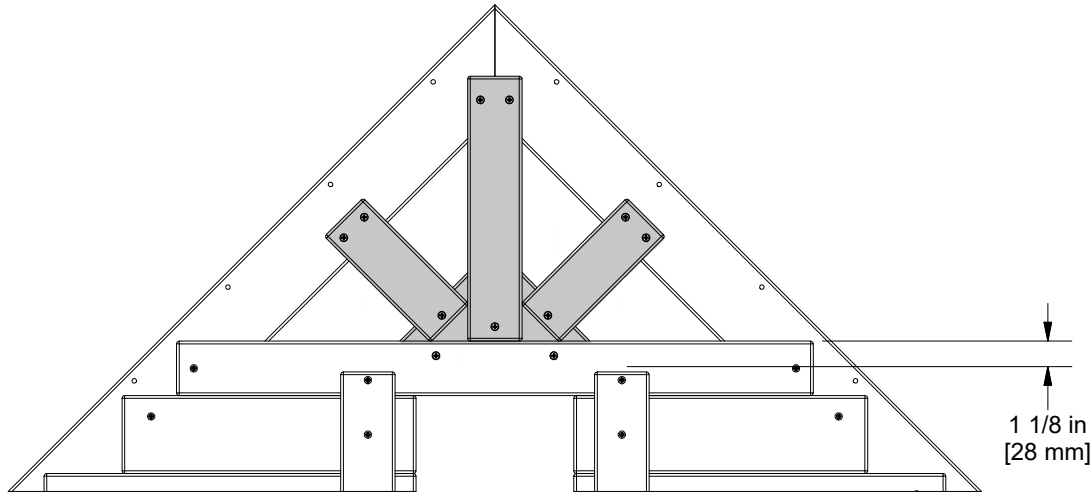

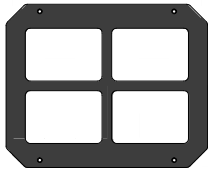
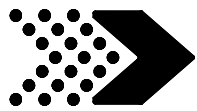

**A100146** | WINDOW  
(1) | 216x267 GREEN



**H100070** | SCREW PWH  
(4) | 8x3/4

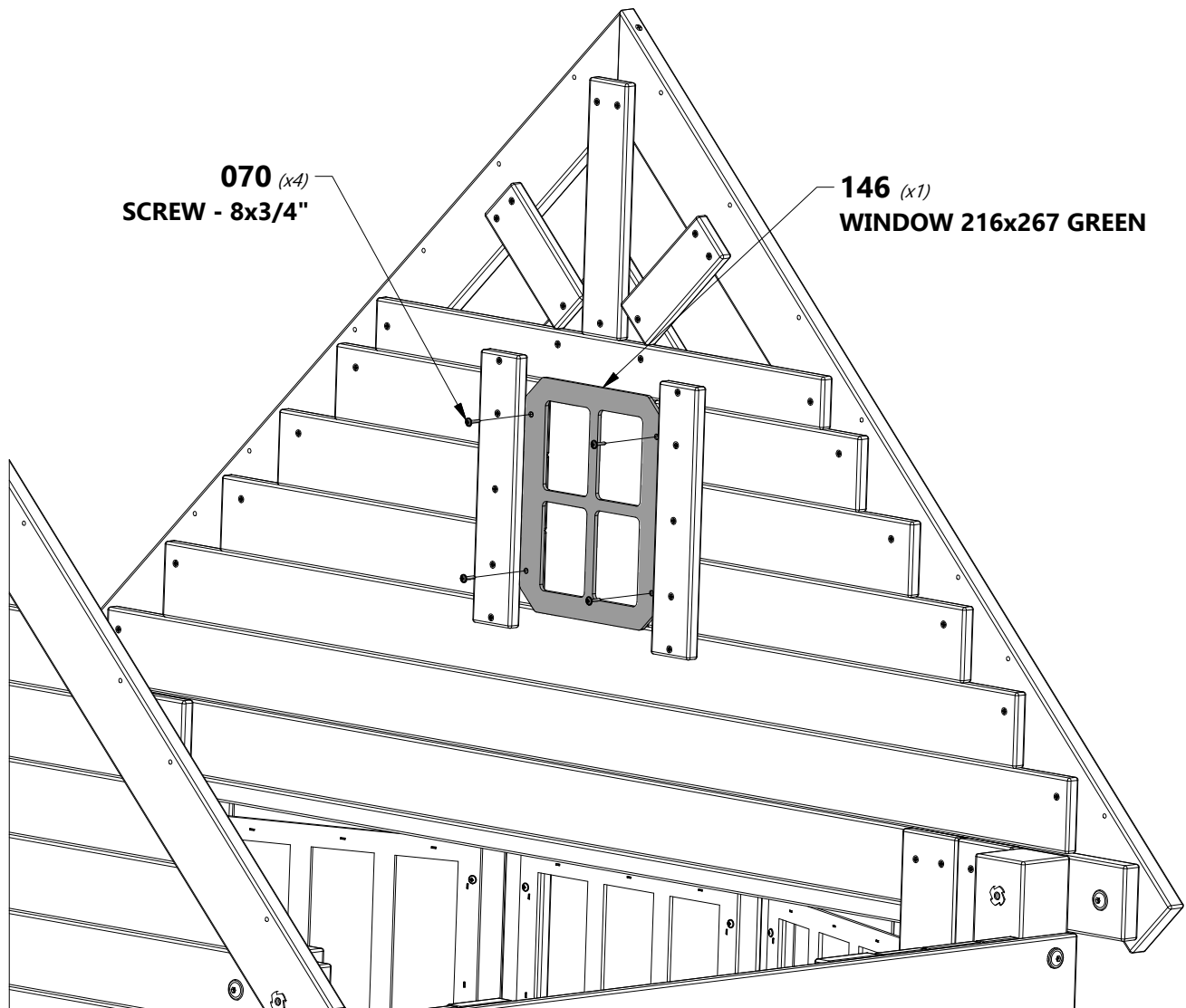

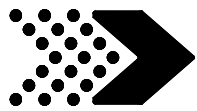

**M11** | SOFFIT CAP - W4L04653  
(1) | 5/8"x3 3/8"x50 1/4" (16x86x1277)



**N2** | SOFFIT CAP - W4L04654  
(1) | 5/8"x2 3/8"x50 1/4" (16x60x1277)



**H100086** | SCREW PFH  
(6) | 8x1 1/2

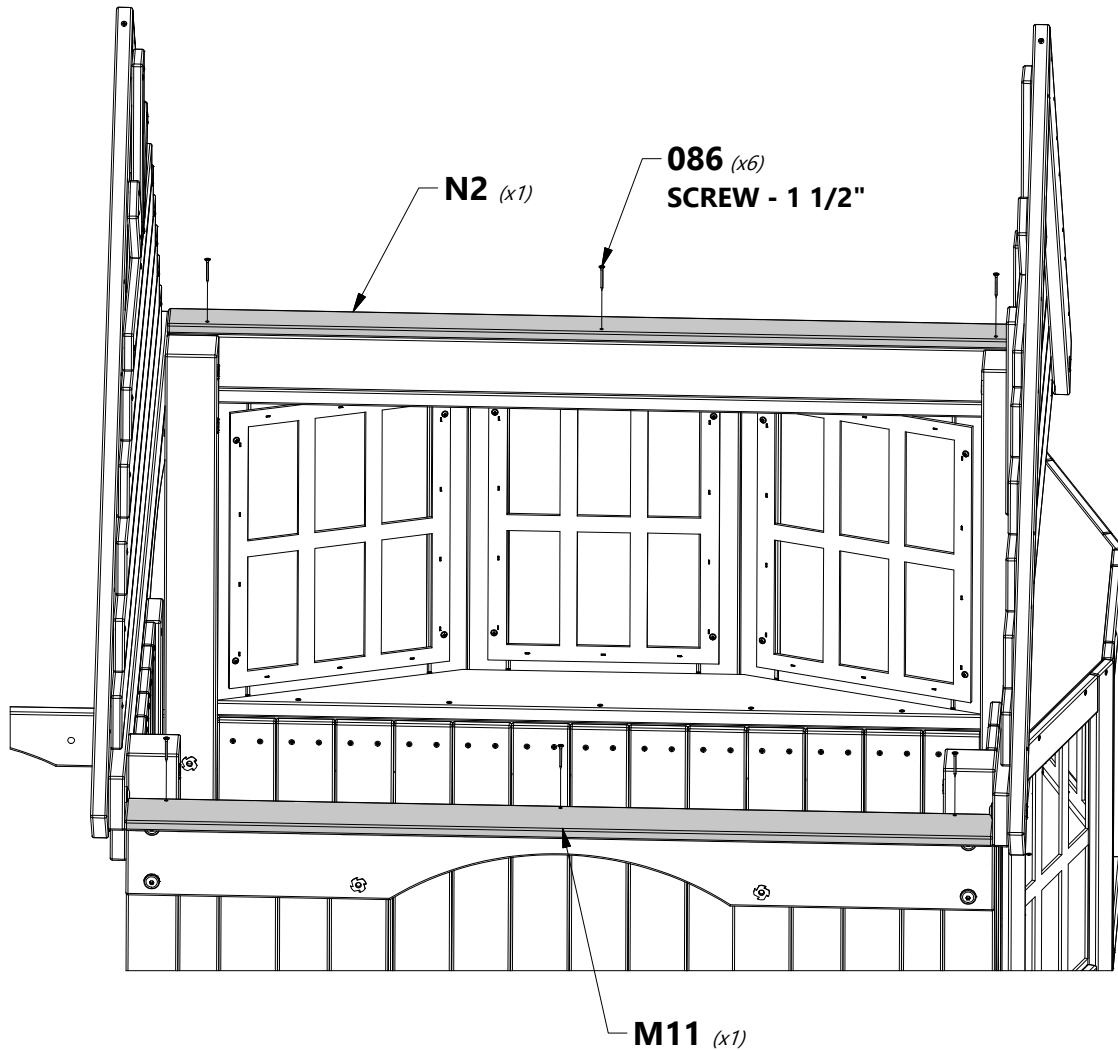
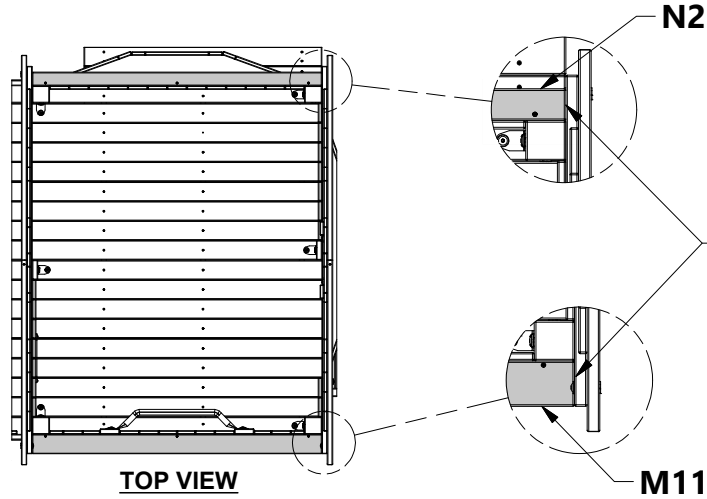

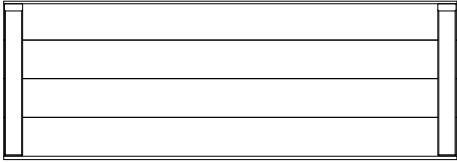
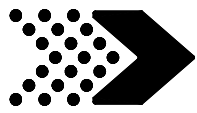

**RP3** | PEAK ROOF PANEL - W2A02626  
(1) | 1 5/8"x20 5/8"x59" (42x524x1499)

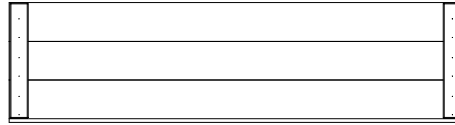

**RP6** | ROOF PANEL - W2A02627  
(2) | 1 5/8"x15 5/8"x59" (42x396x1499)



**H100091** | SCREW PFH  
(14) | 8X2 1/4

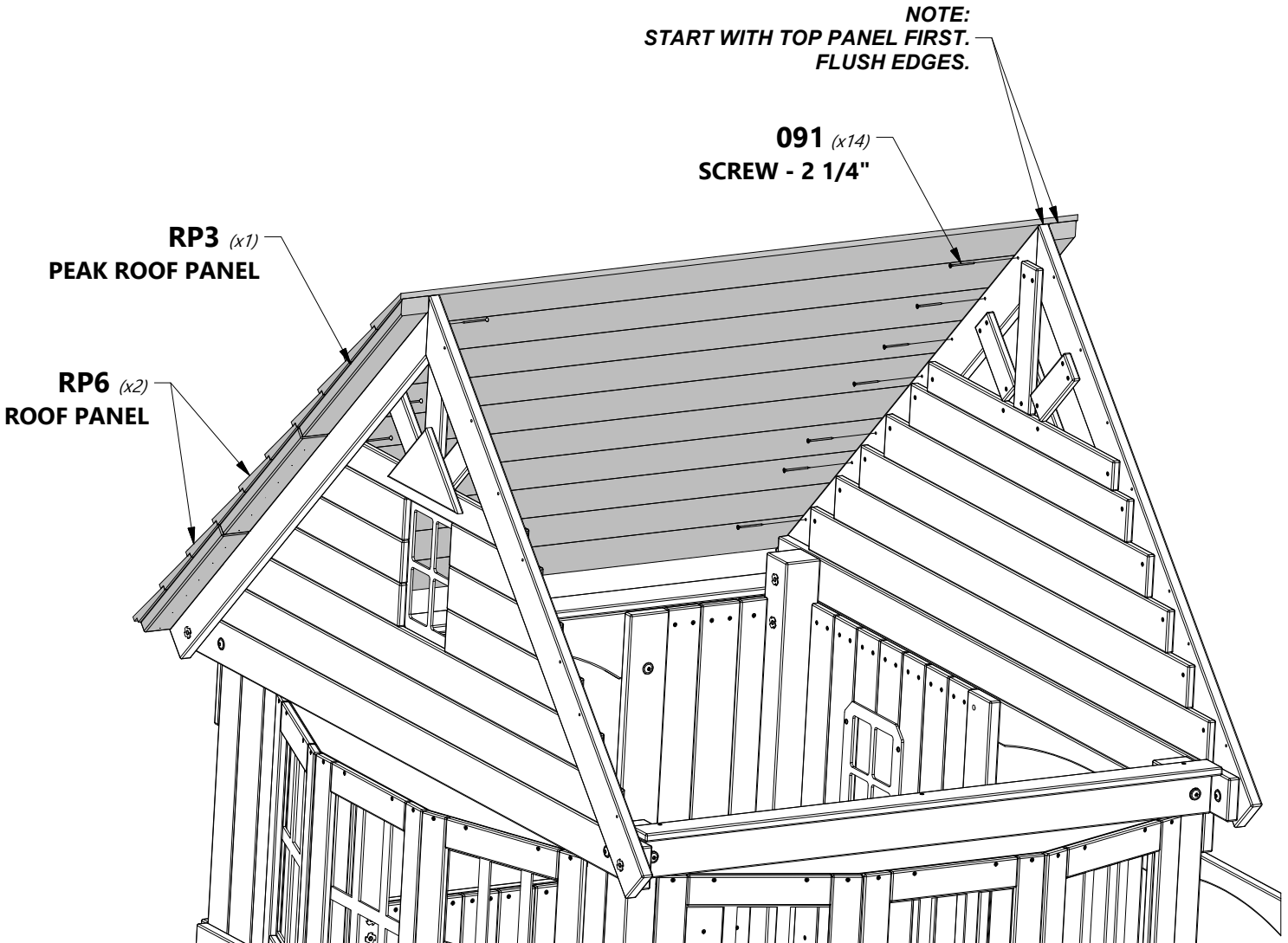

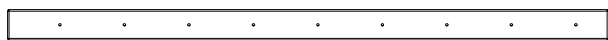

**N3** | ROOF SUPPORT - W103535  
(1) | 5/8"x2 3/8"x47" (16x60x1193)



**H100088** | SCREW PFH  
(9) | 8x1 1/8

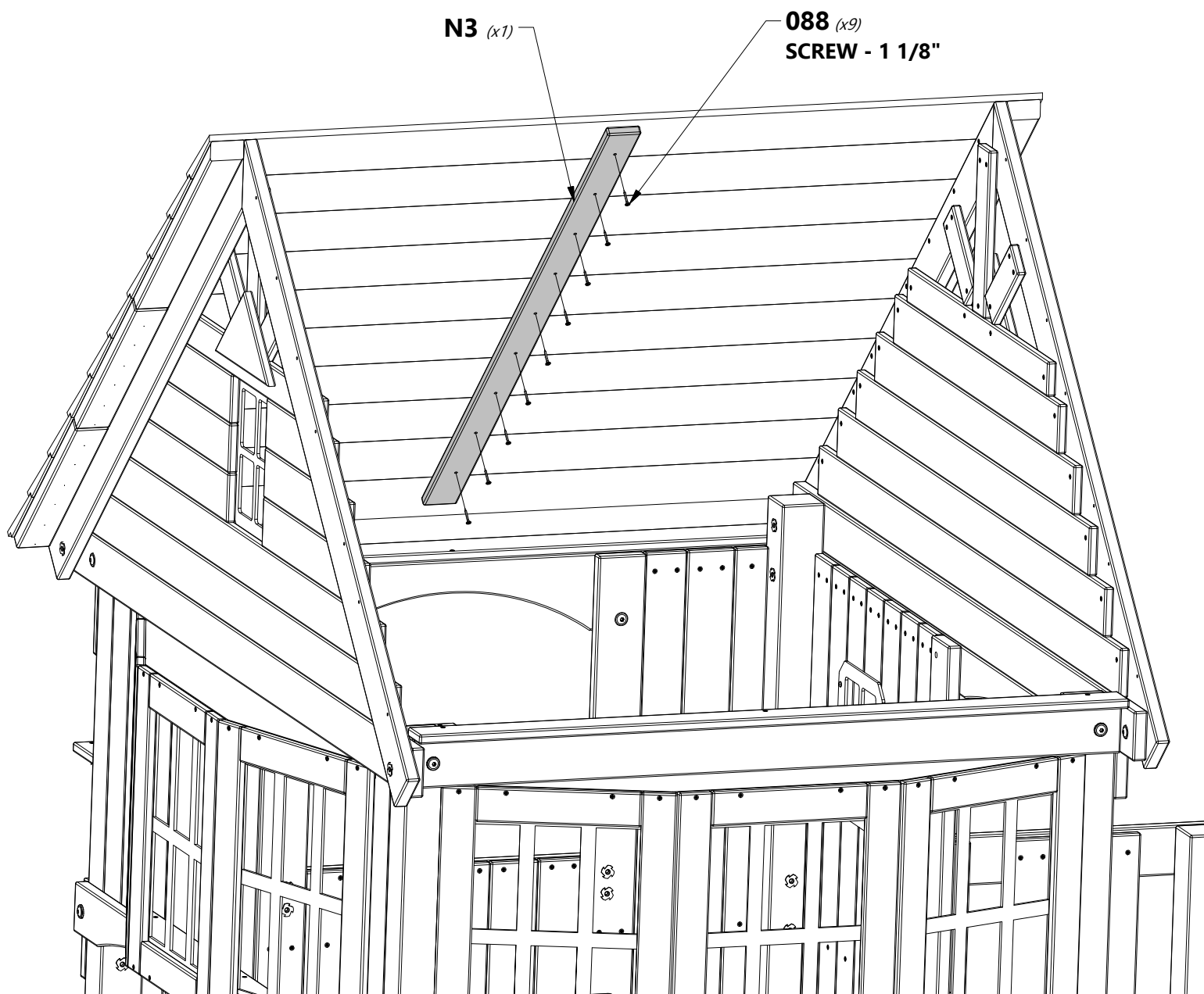
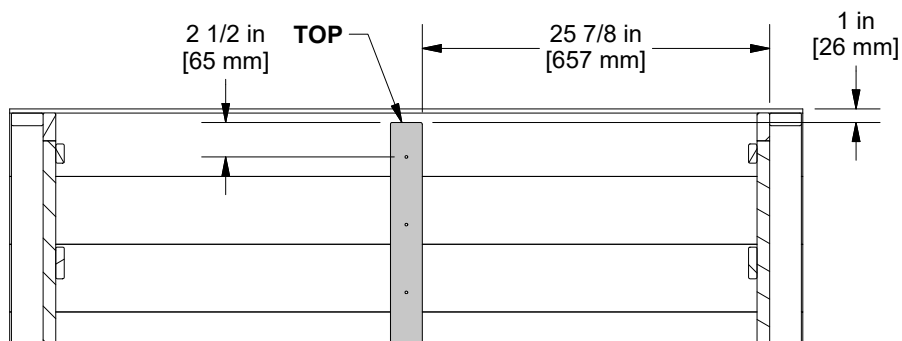

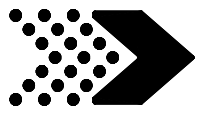

**REPEAT STEPS 49 & 50 TO ATTACH LEFT  
SIDE ROOF PANELS.**



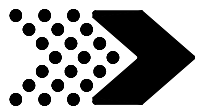

(1) PORCH ROOF ASSEMBLY



**H100015** | BOLT WH  
(1) | 5/16x2 3/4

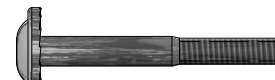

**H100014** | BOLT WH  
(2) | 5/16x2 1/2



**H100030** | WASHER LOCK  
(4) | EXT  
8x19

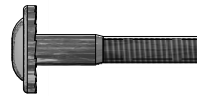

**H100011** | BOLT WH  
(1) | 5/16x1 3/4



**H100074** | T-NUT  
(4) | 5/16



**TIP:**  
INSTALL T-NUTS INTO  
BOARDS BEFORE ASSEMBLY.

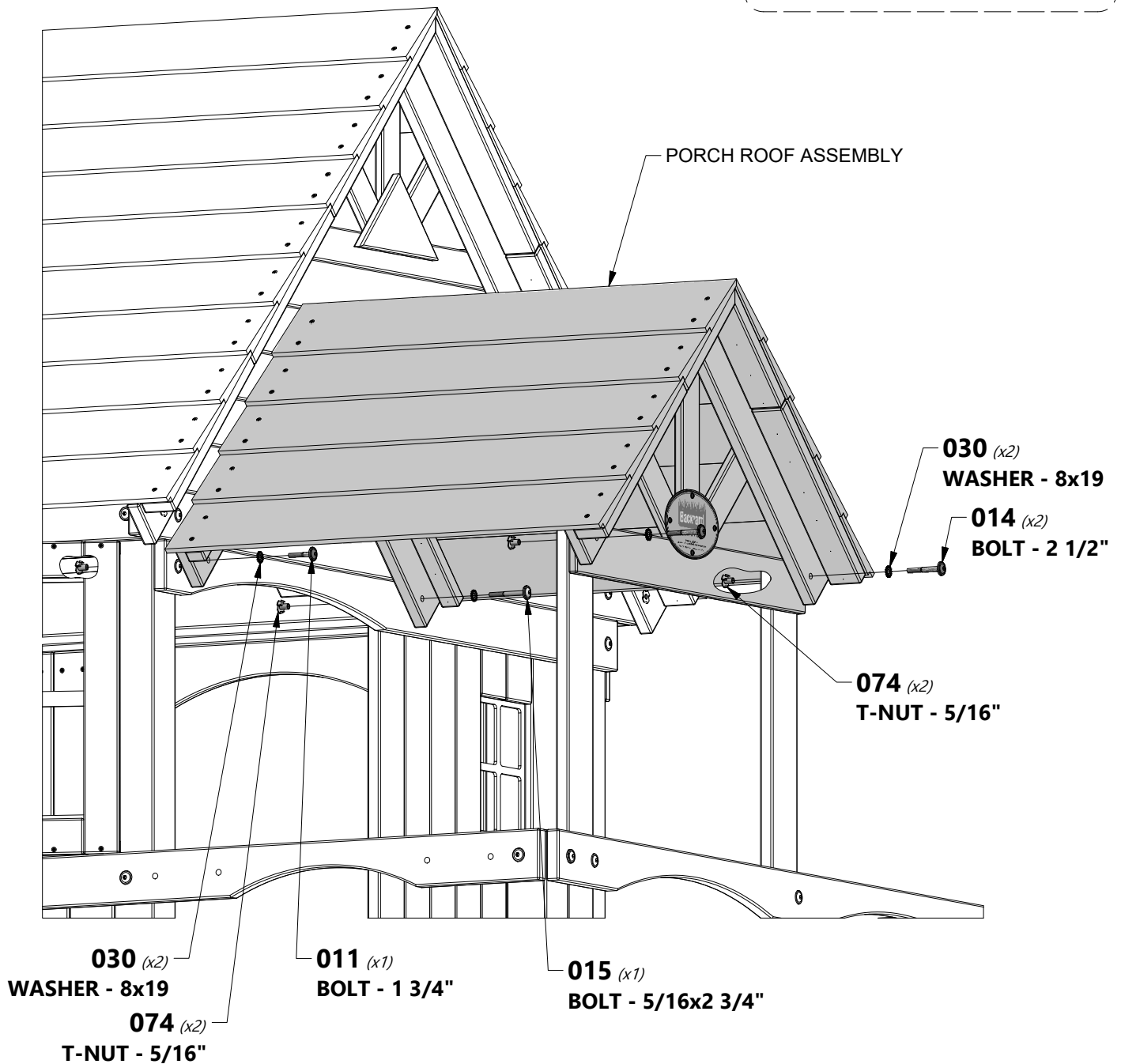



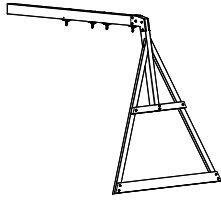

(1) SWING BEAM ASSEMBLY



H100043 | BOLT HEX  
(4) | 5/16x1 3/4



H100095 | WASHER SPLIT  
(4) | 5/16



H100074 | T-NUT  
(4) | 5/16



H100105 | WASHER FLAT  
(4) | 8x27

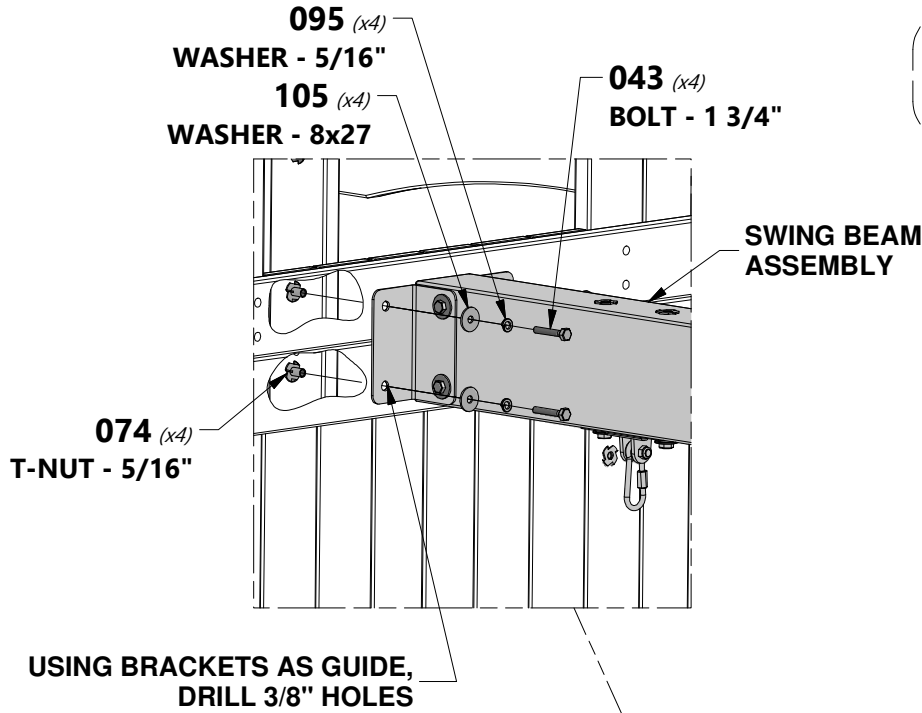

**TIP:**  
INSTALL T-NUTS INTO  
BOARDS BEFORE ASSEMBLY.

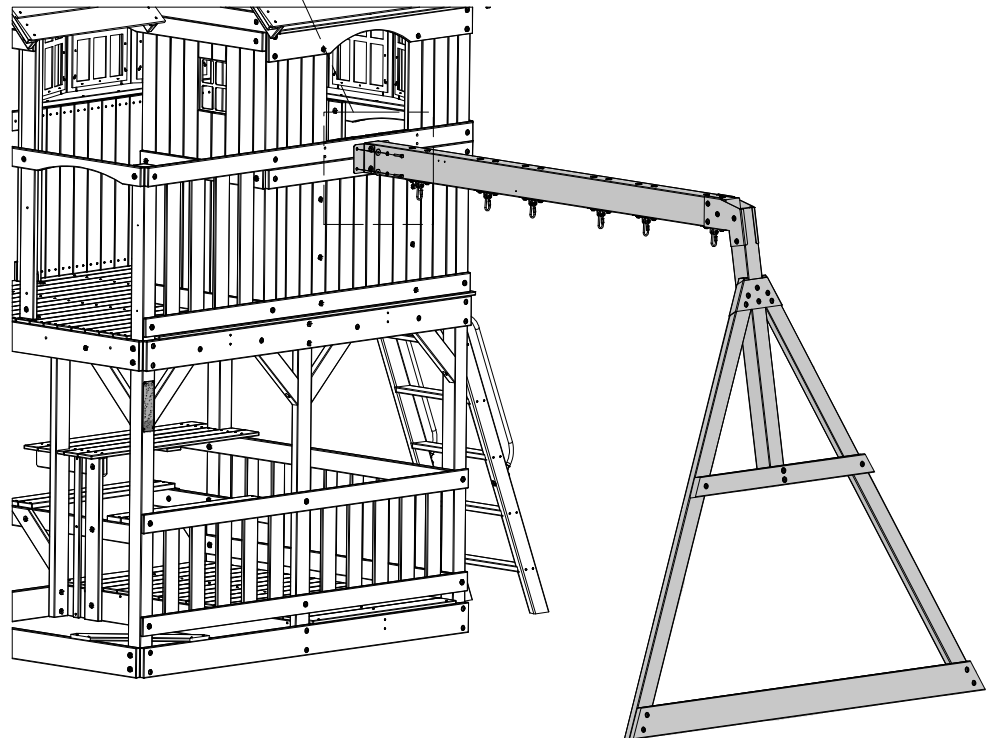

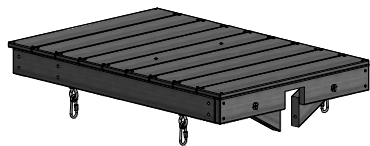

(1) CROW'S NEST DECK ASSEMBLY



H100649 | LAG SCREW WH  
(2) | 1/4x2 1/2

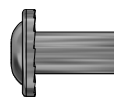

H100005 | NUT BARREL WH  
(4) | 5/16x7/8



H100042 | BOLT HEX  
(4) | 5/16x1 1/4



H100086 | SCREW PFH  
(2) | 8x1 1/2



H100105 | WASHER FLAT  
(4) | 8x27



H100095 | WASHER SPLIT  
(4) | 5/16



H100138 | WASHER LOCK  
(2) | EXT  
6x15



H100031 | WASHER LOCK  
(4) | EXT  
12x19



649 (x2)  
LAG SCREW - 2 1/2"

138 (x2)  
WASHER - 6x15

086 (x2)  
SCREW - 1 1/2"  
(TOP SIDE)

031 (x4)  
WASHER - 12x19

005 (x4)  
NUT BARREL - 7/8"

105 (x4)  
WASHER - 8x27

095 (x4)  
WASHER - 5/16"

042 (x4)  
BOLT HEX - 1 1/4"

CROWS NEST ASSEMBLY



**A100396 | L BRACKET**  
(2) | 51x32x82x3.175



**H100066 | LAG SCREW**  
(8) | 5/16x1 1/2



**H100095 | WASHER SPLIT**  
(8) | 5/16



**H100105 | WASHER FLAT**  
(8) | 8x27

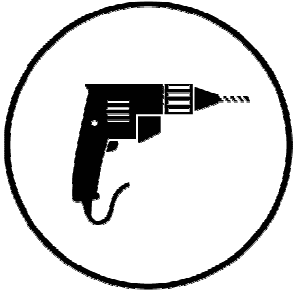

**066 (x8)**  
LAG SCREW - 1 1/2"

**095 (x8)**  
WASHER - 5/16"

**105 (x8)**  
WASHER - 8x27

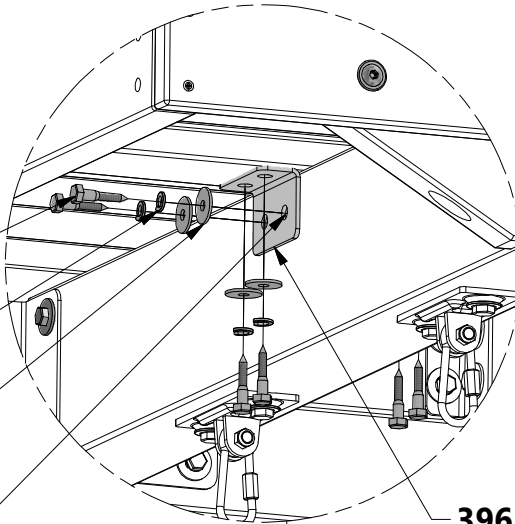

**396 (x2)**  
L BRACKET

**⚠ USING BRACKET AS GUIDE, DRILL 3/16 in [5 mm] HOLES.**

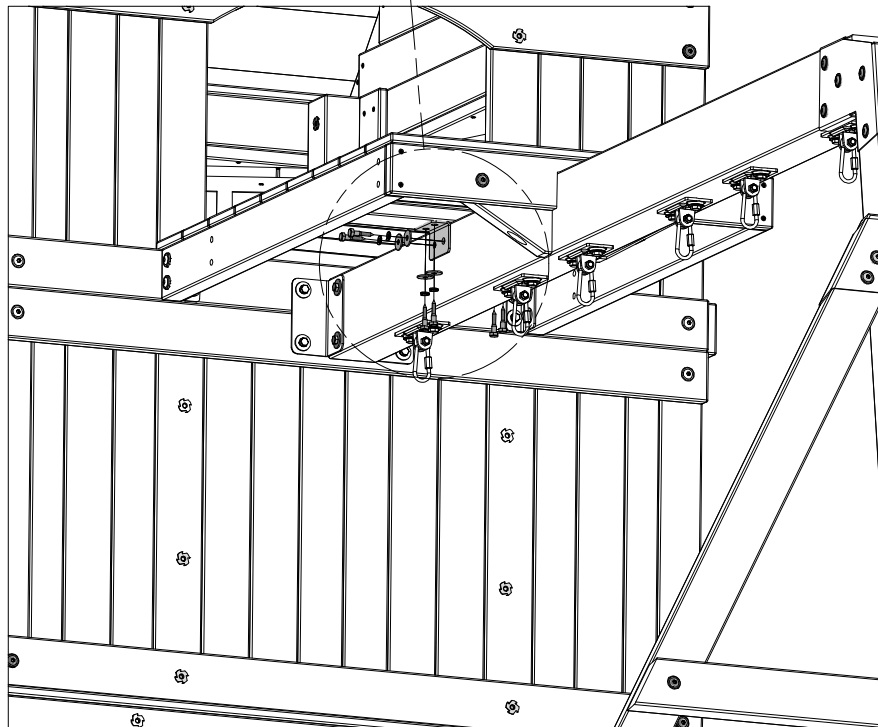

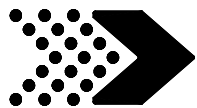

**F03** | CROWS NEST WALL SUPPORT - W4L15909  
(2) | 1 3/8"x2 3/8"x37 1/2" (36x60x952)



**F02** | CROWS NEST WALL SUPPORT - W4L15908  
(2) | 1 3/8"x2 3/8"x37 1/2" (36x60x952)



**H100015** | BOLT WH  
(8) | 5/16x2 3/4



**H100030** | WASHER LOCK  
(8) | EXT  
8x19



**H100074** | T-NUT  
(4) | 5/16



**TIP:**  
INSTALL T-NUTS INTO  
BOARDS BEFORE ASSEMBLY.

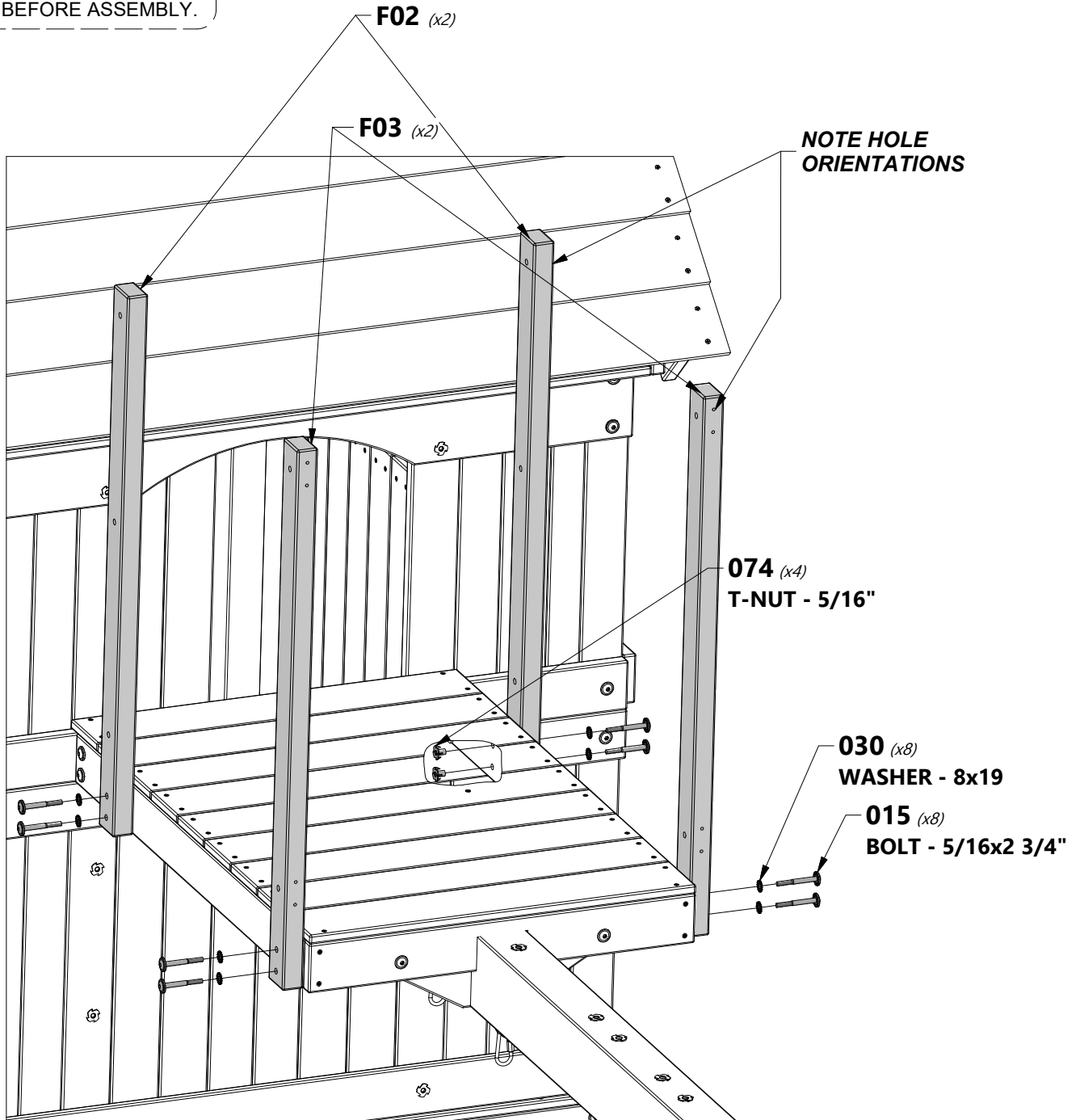

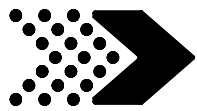

**H31** | CROWS NEST WALL RAIL - W4L15907  
(2) | 1"x3 3/8"x38 7/8" (24x86x988)

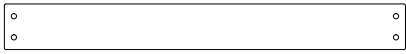

**H30** | CROWS NEST WALL RAIL - W4L11782  
(1) | 1"x3 3/8"x29 7/8" (24x86x758)



**H100028** | LAG SCREW WH  
(4) | 5/16x2 1/2

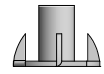

**H100074** | T-NUT  
(4) | 5/16



**H100013** | BOLT WH  
(4) | 5/16x2 1/4



**H100030** | WASHER LOCK  
(8) | EXT  
8x19



**TIP:**  
INSTALL T-NUTS INTO  
BOARDS BEFORE ASSEMBLY.

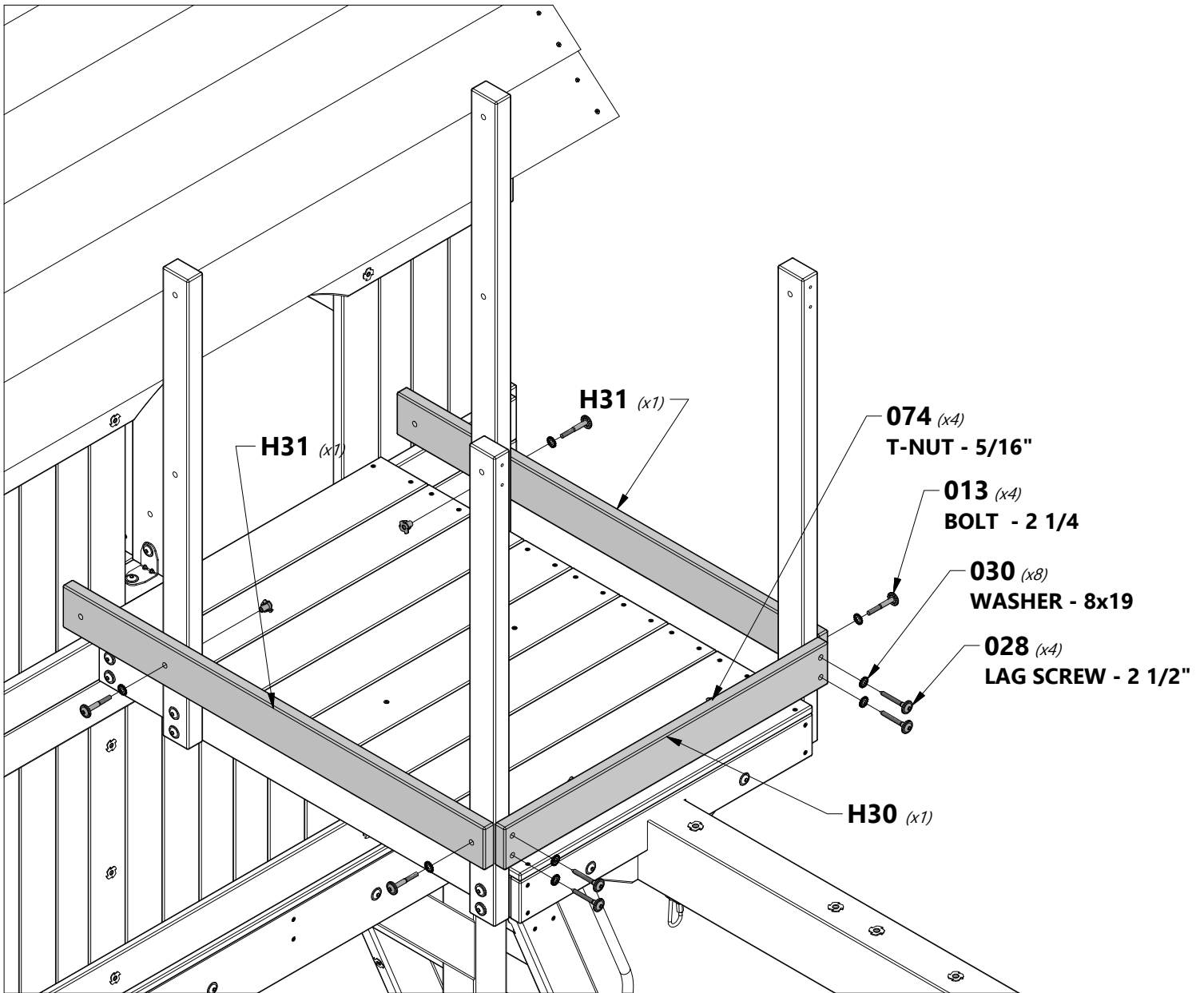



**A4M01046** | L BRACKET  
(2) | 2.5x38x55x55

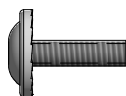

**H100008** | BOLT WH  
(2) | 5/16x1



**H100115** | BOLT WH  
(2) | 5/16x1/2



**H100074** | T-NUT  
(4) | 5/16



**TIP:**  
INSTALL T-NUTS INTO  
BOARDS BEFORE ASSEMBLY.

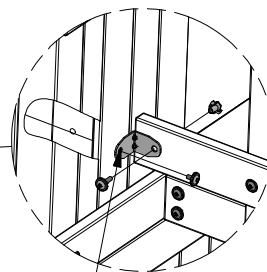
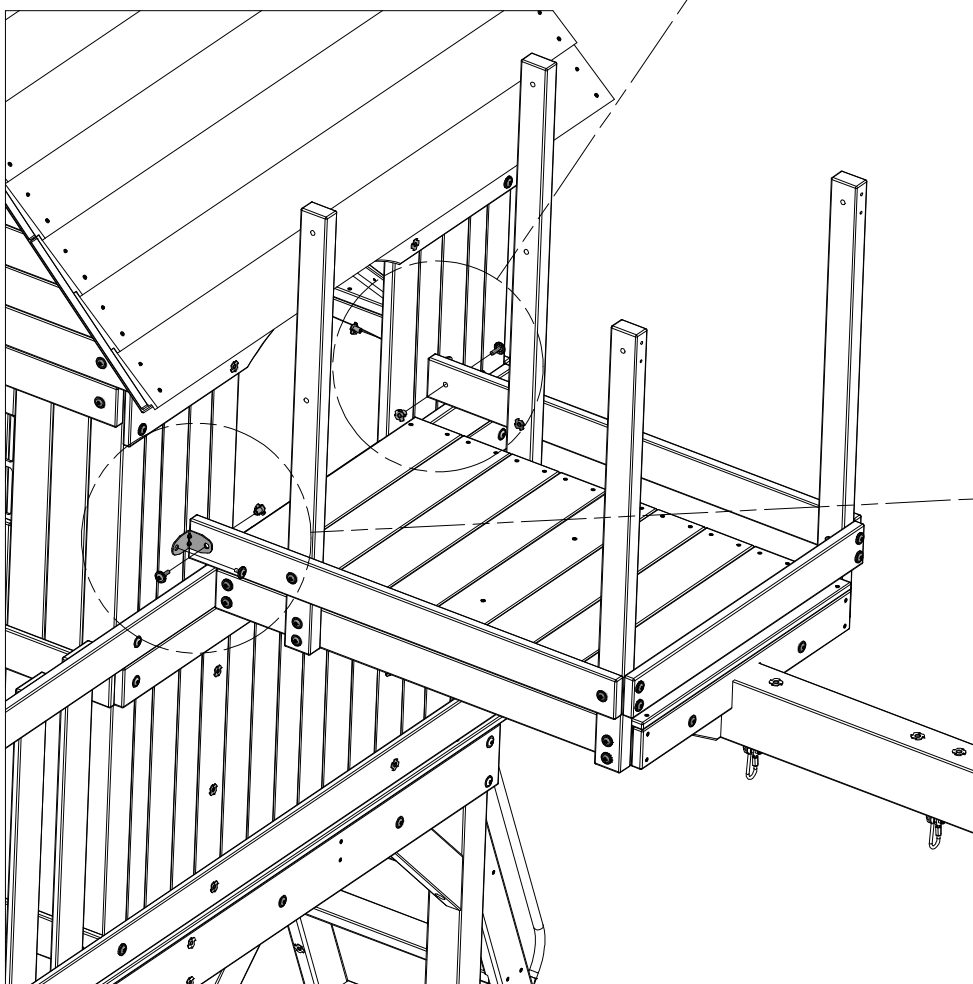
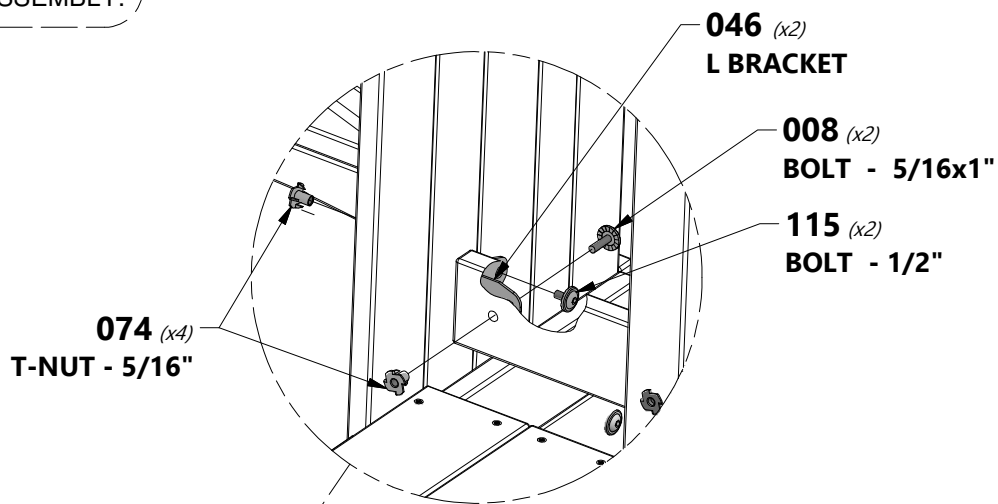

**USING BRACKETS AS A GUIDE,  
DRILL 3/8 in [10 mm] HOLES  
THROUGH WALL BOARD.**

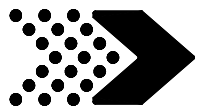

**M4** | CROWS NEST WALL RAIL - W4L11773  
(2) | 5/8"x3 3/8"x29 7/8" (16x86x758)

**H30** | CROWS NEST WALL RAIL - W4L11782  
(1) | 1"x3 3/8"x29 7/8" (24x86x758)

**H29** | CROWS NEST WALL RAIL - W4L15910  
(2) | 1"x3 3/8"x30 5/8" (24x86x778)



**H100013** | BOLT WH  
(4) | 5/16x2 1/4



**H100028** | LAG SCREW WH  
(4) | 5/16x2 1/2



**H100027** | LAG SCREW WH  
(8) | 5/16x2



**H100030** | WASHER LOCK  
(16) | EXT  
8x19

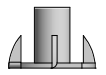

**H100074** | T-NUT  
(4) | 5/16



**TIP:**  
INSTALL T-NUTS INTO  
BOARDS BEFORE ASSEMBLY.

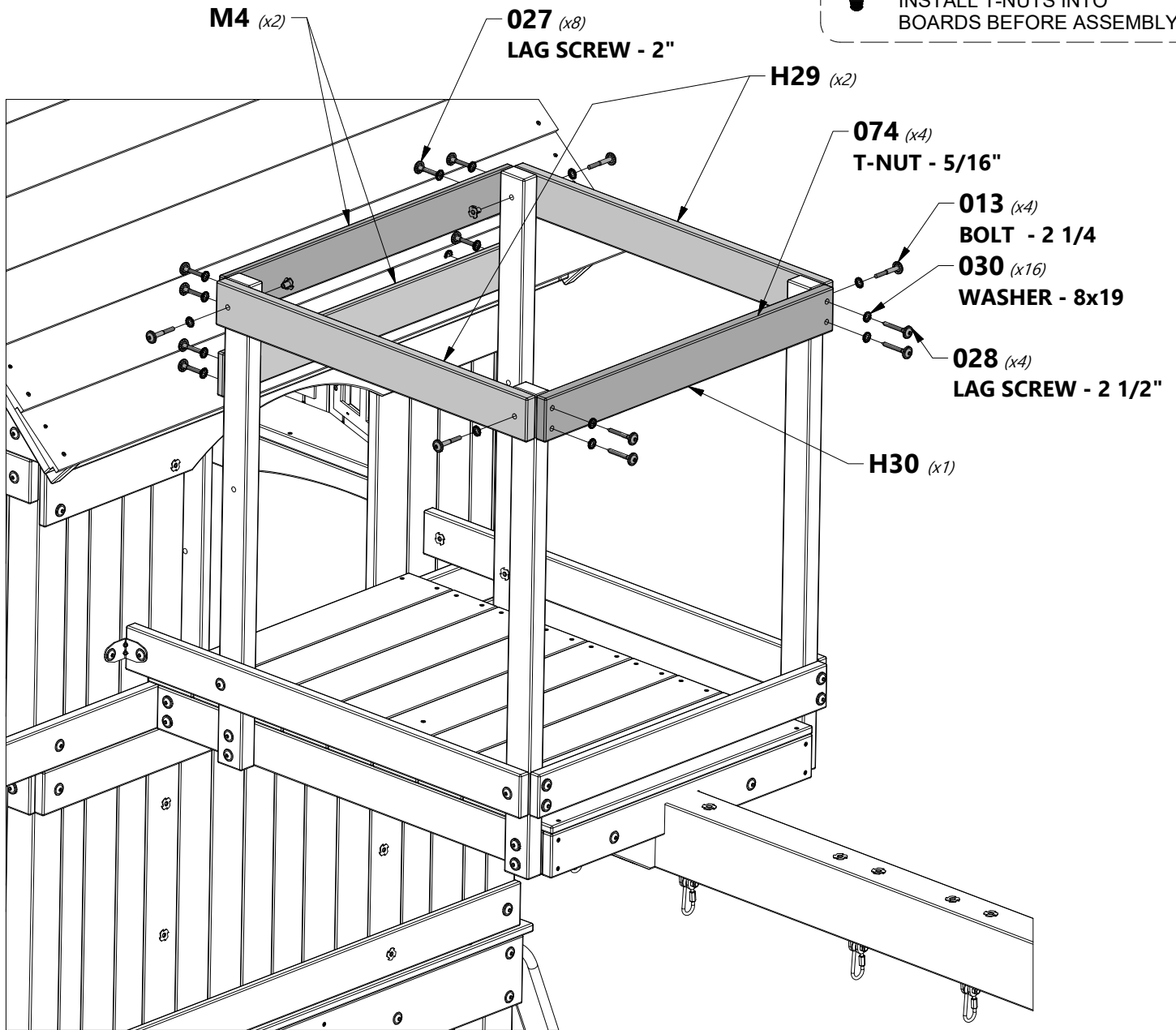

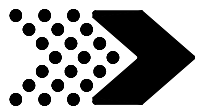

# FORT ASSEMBLY

# STEP 60

1 1/8 in [30 mm]      1 3/4 in [43 mm]



**M32** | CROWS NEST WALL RAIL - W4L04671  
(2) | 5/8"x3 3/8"x10" (16x86x254)



**A4M01046** | L BRACKET  
(2) | 2.5x38x55x55



**H100012** | BOLT WH  
(2) | 5/16x2



**H100009** | BOLT WH  
(2) | 5/16x1 1/4



**H100115** | BOLT WH  
(2) | 5/16x1/2



**H100074** | T-NUT  
(6) | 5/16



**H100030** | WASHER LOCK  
(2) | EXT  
8x19



**TIP:**  
INSTALL T-NUTS INTO  
BOARDS BEFORE ASSEMBLY.



**USING BRACKETS  
AS A GUIDE, DRILL  
3/8in [10mm] HOLES  
THROUGH WALL.**

**046 (x2)**  
L BRACKET

**009 (x2)**  
BOLT - 1 1/4"

**M32 (x2)**

**074 (x6)**  
T-NUT - 5/16"

**030 (x2)**  
WASHER - 8x19

**012 (x2)**  
BOLT - 2"

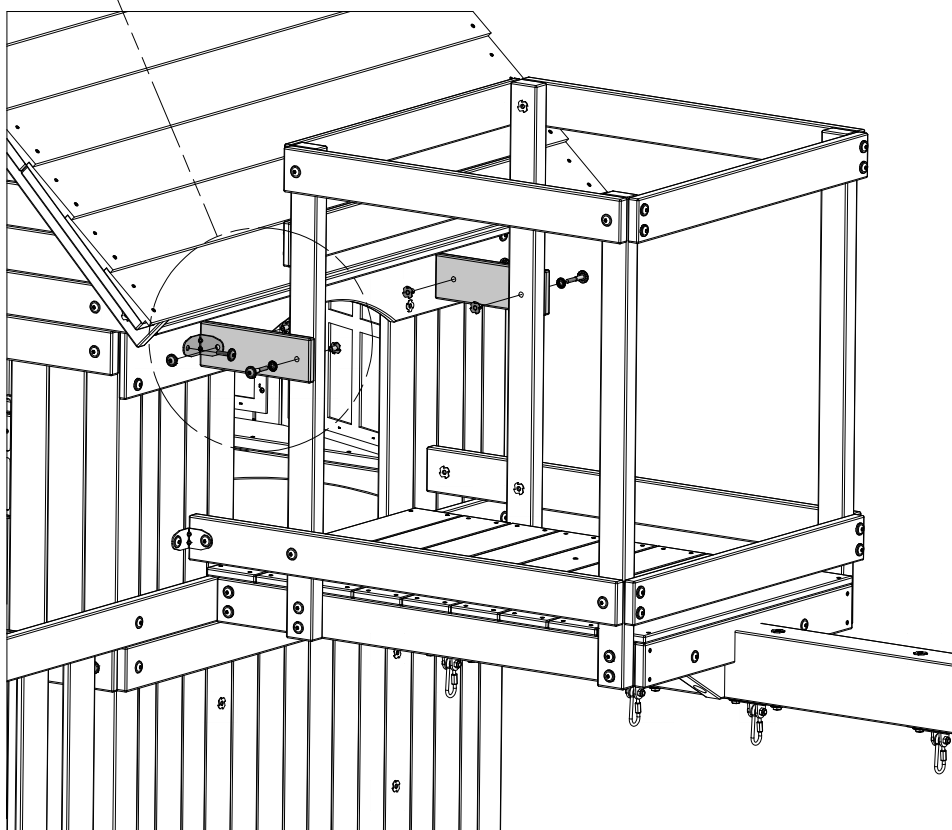
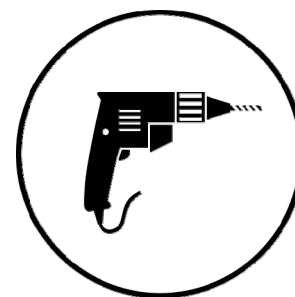



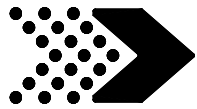

**N04** | CROWS NEST WALL BOARD - W4L15912  
(2) | 5/8"x2 3/8"x18 1/8" (16x60x461)



**H100088** | SCREW PFH  
(4) | 8x1 1/8

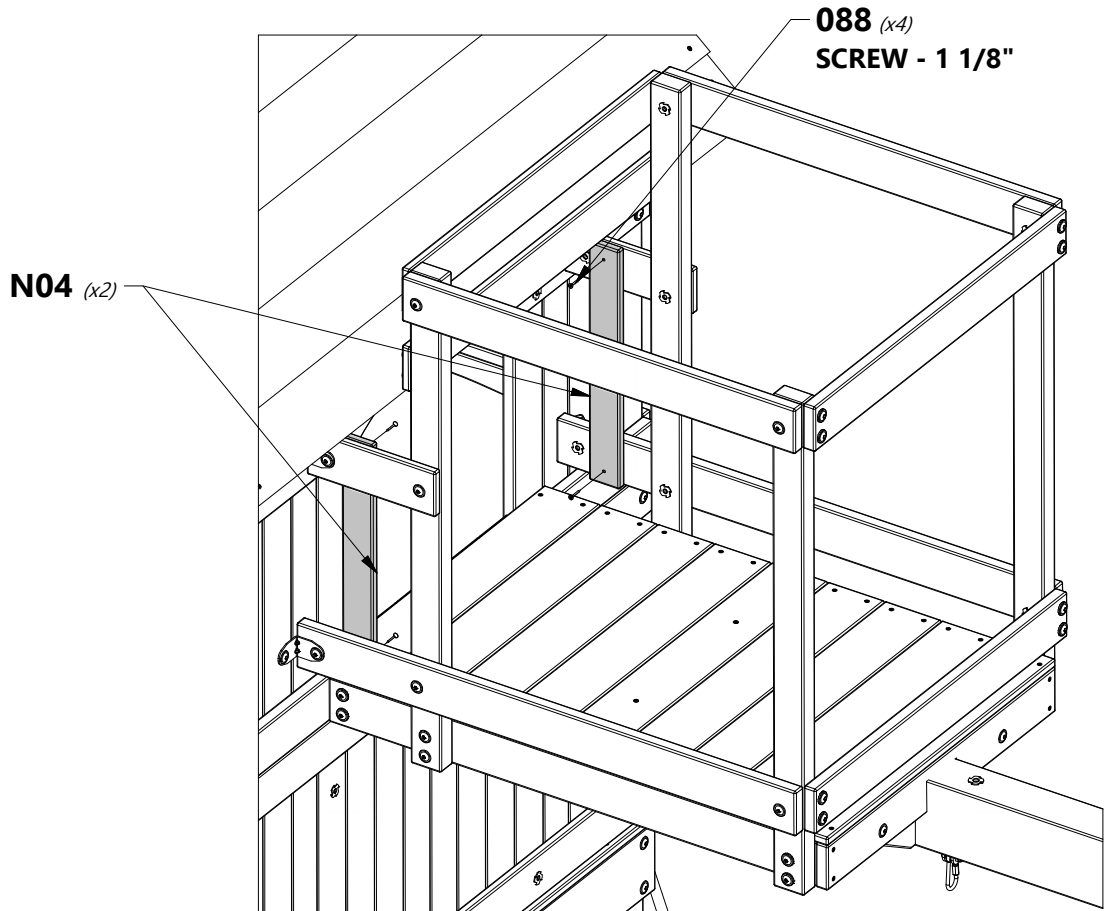
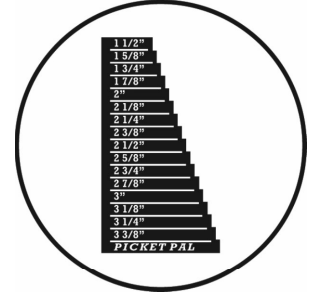
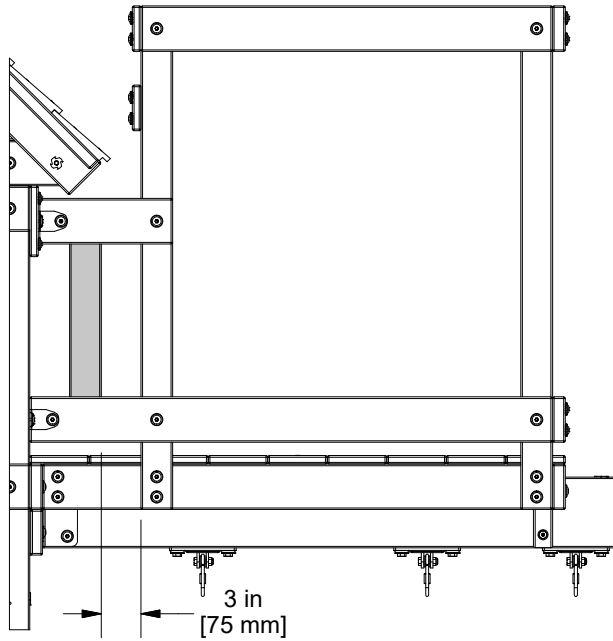

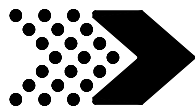

**O1** | CROWS NEST WALL BOARD - W4L15911  
 (6) | 5/8"x1 3/8"x32 1/4" (16x34x819)

**H100088** | SCREW PFH  
 (12) | 8x1 1/8"

2 3/4 in  
 [69 mm]  
 EQUAL SPACING

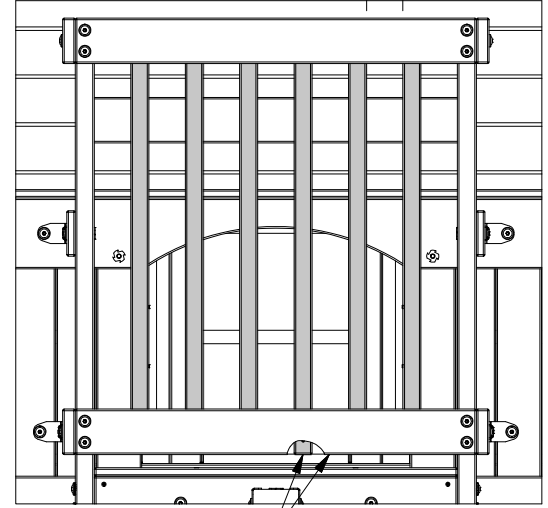

**088** (x12)  
 SCREW - 1 1/8"

**O1** (x6)

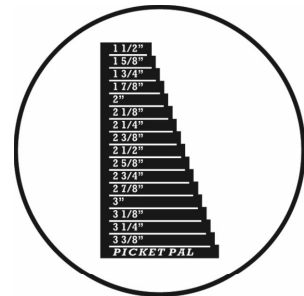
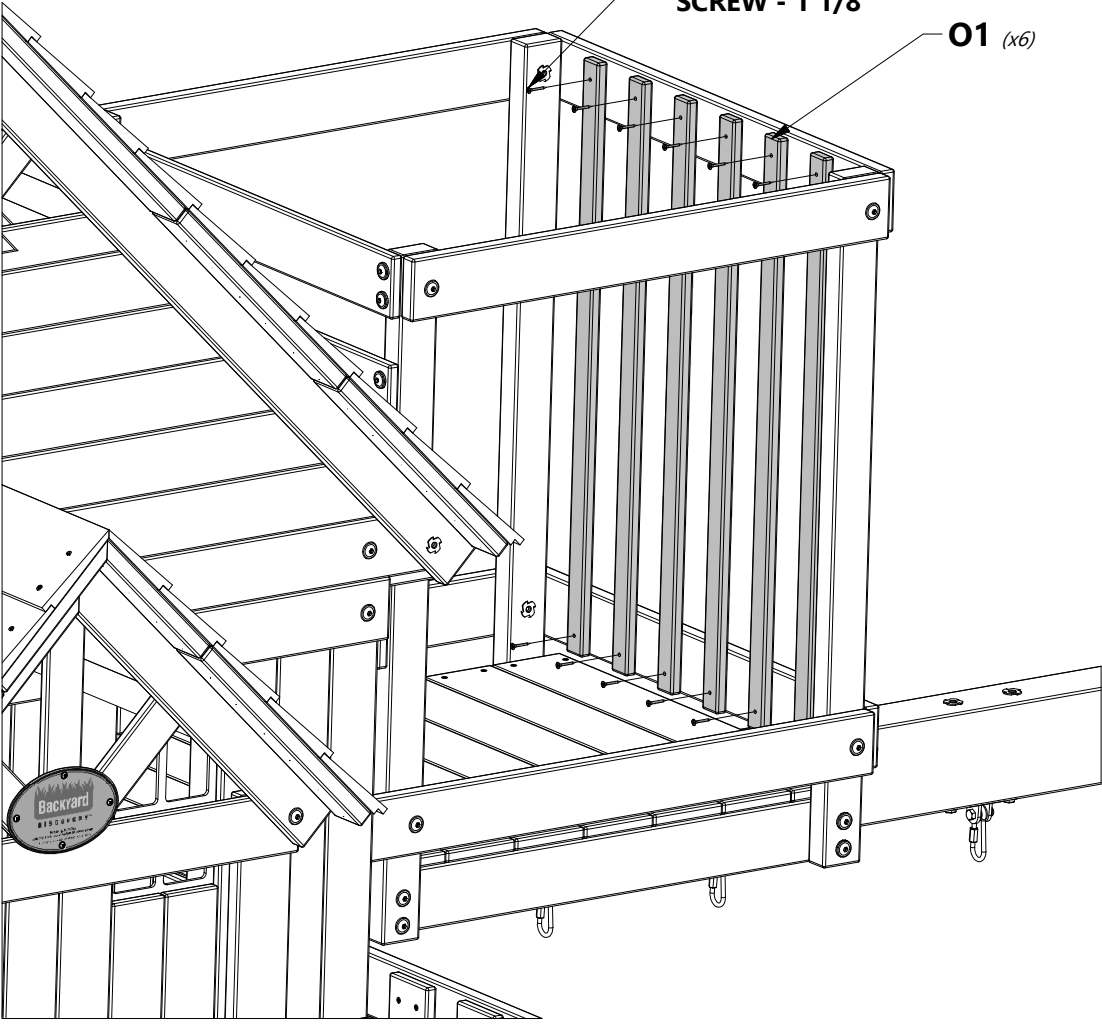

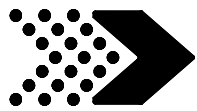

**O1** | CROWS NEST WALL BOARD - W4L15911  
(12) | 5/8"x1 3/8"x32 1/4" (16x34x819)



**H100088** | SCREW PFH  
(24) | 8x1 1/8"

2 1/2 in  
[65 mm]  
EQUAL  
SPACING

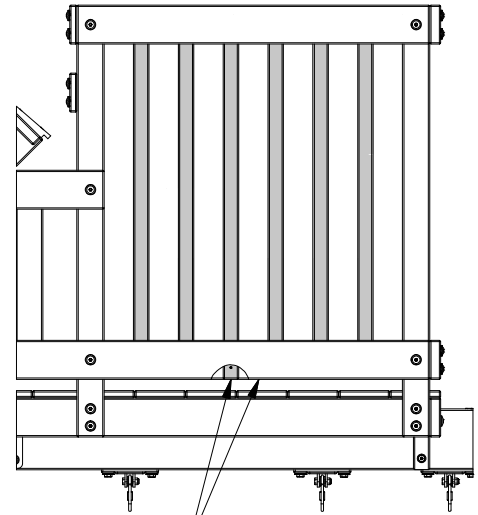

**088** (x24)  
SCREW - 1 1/8"

**O1** (x12)

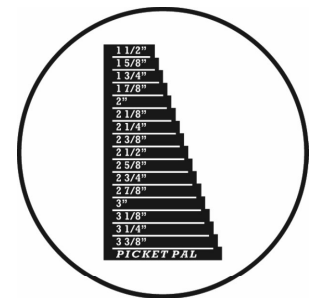
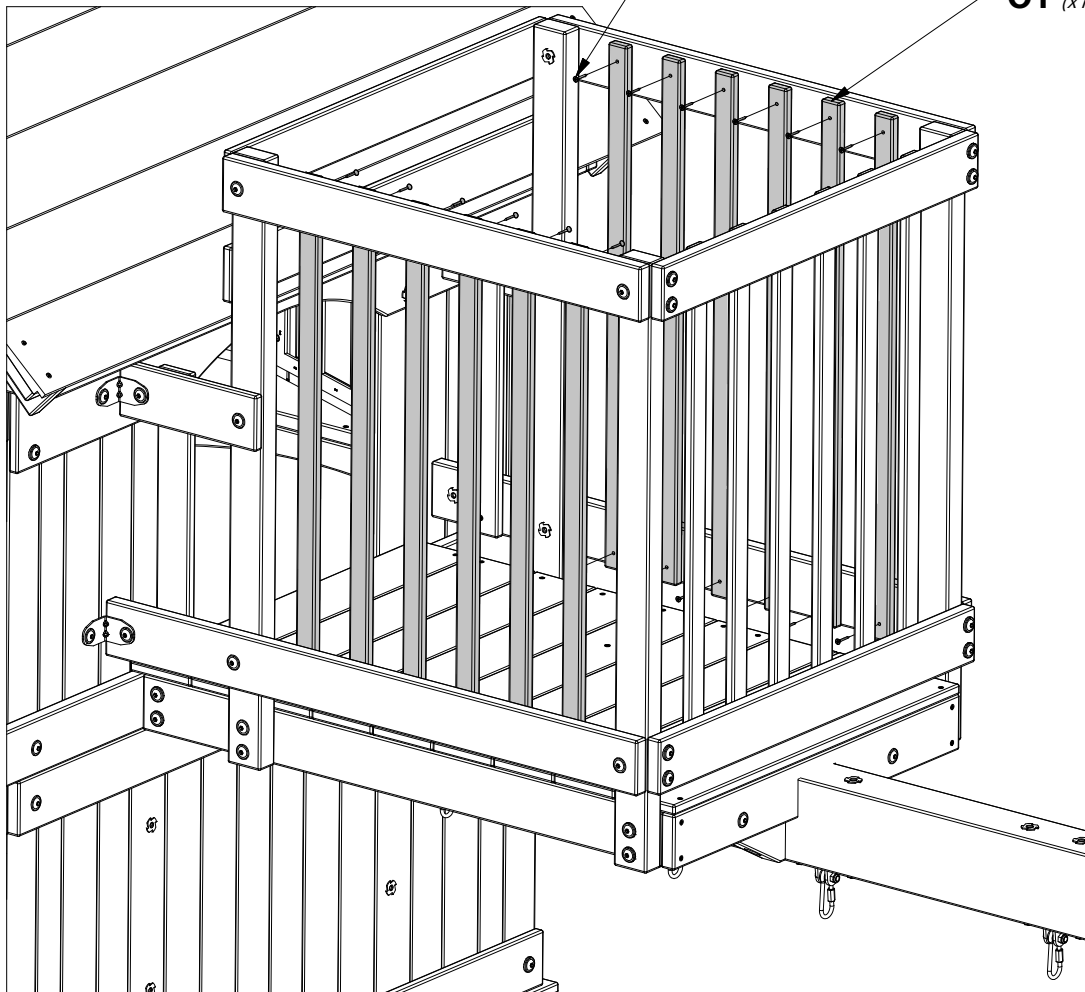

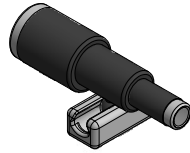
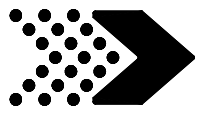



**A6P00096** | TELESCOPE  
(1)



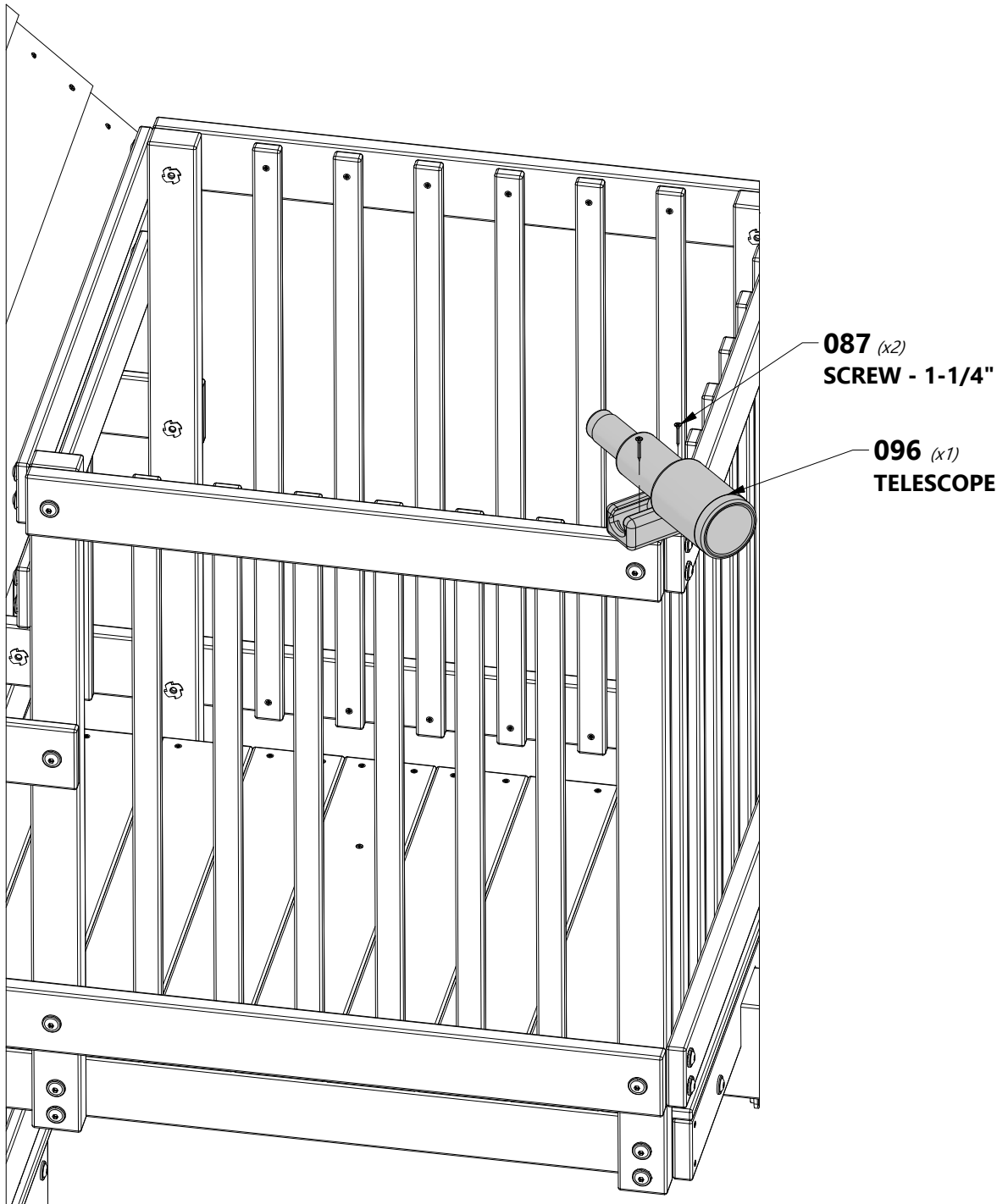

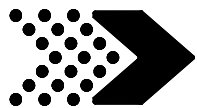
**H100087** | SCREW PFH  
(2) | 8x1-1/4"





  
**A100118** | **HAND GRIP**  
 (4) | **METAL GREEN**  
 381 c/c

  
**H100026** | **LAG SCREW WH**  
 (4) | 5/16x1 1/2

  
**H100008** | **BOLT WH**  
 (4) | 5/16x1

  
**H100074** | **T-NUT**  
 (4) | 5/16



**TIP:**  
 INSTALL T-NUTS INTO  
 BOARDS BEFORE ASSEMBLY.

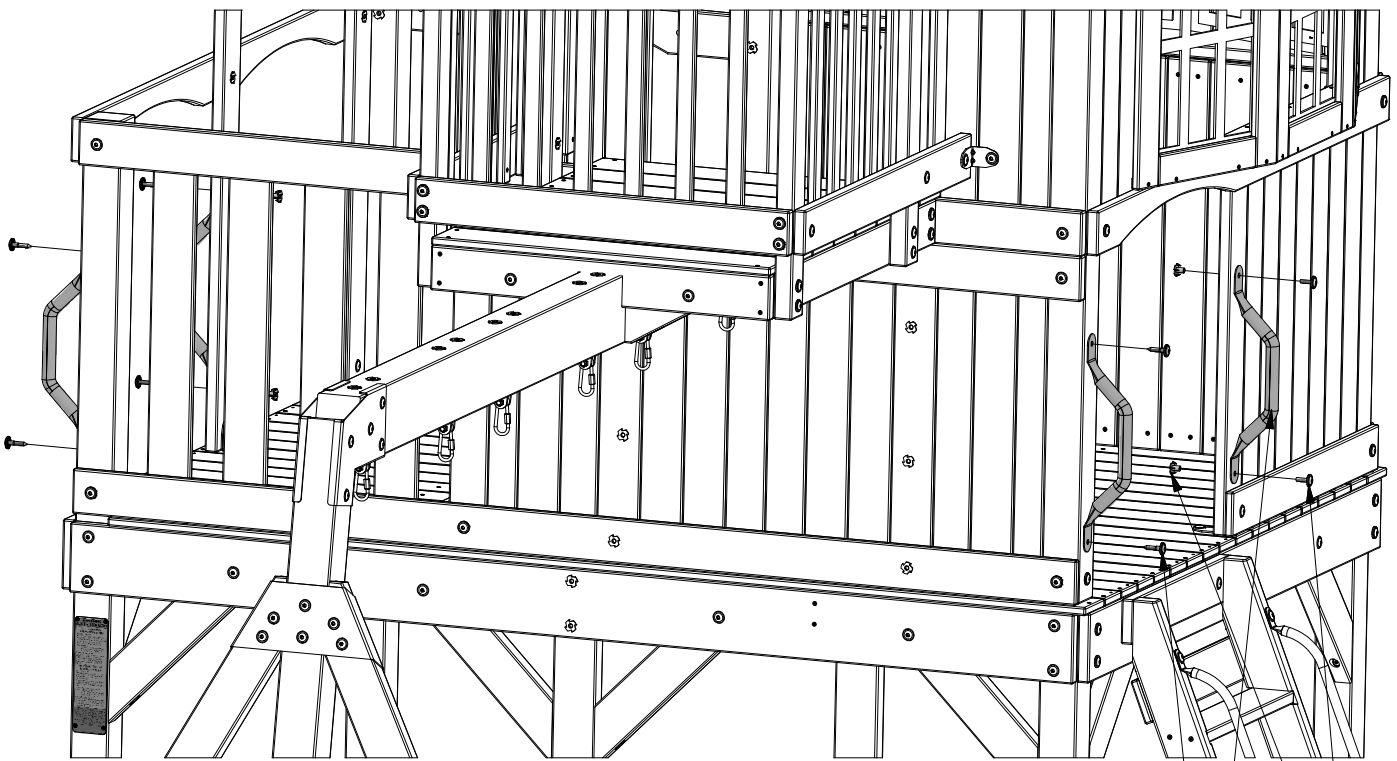

**026** (x4)  
**LAG SCREW - 1 1/2"**

**008** (x4)  
**BOLT - 5/16x1"**

**118** (x4)  
**HAND GRIP METAL GREEN 381 c/c**

**074** (x4)  
**T-NUT - 5/16"**



# FINAL ASSEMBLY

# STEP 1

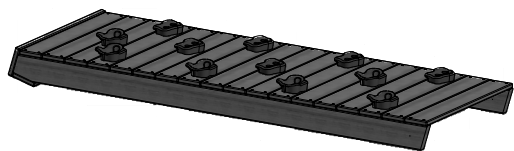

(1) ROCK WALL ASSEMBLY

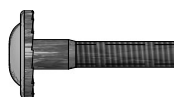

H100010 | BOLT WH  
(2) | 5/16x1-1/2



H100030 | WASHER LOCK  
(2) | EXT  
8x19

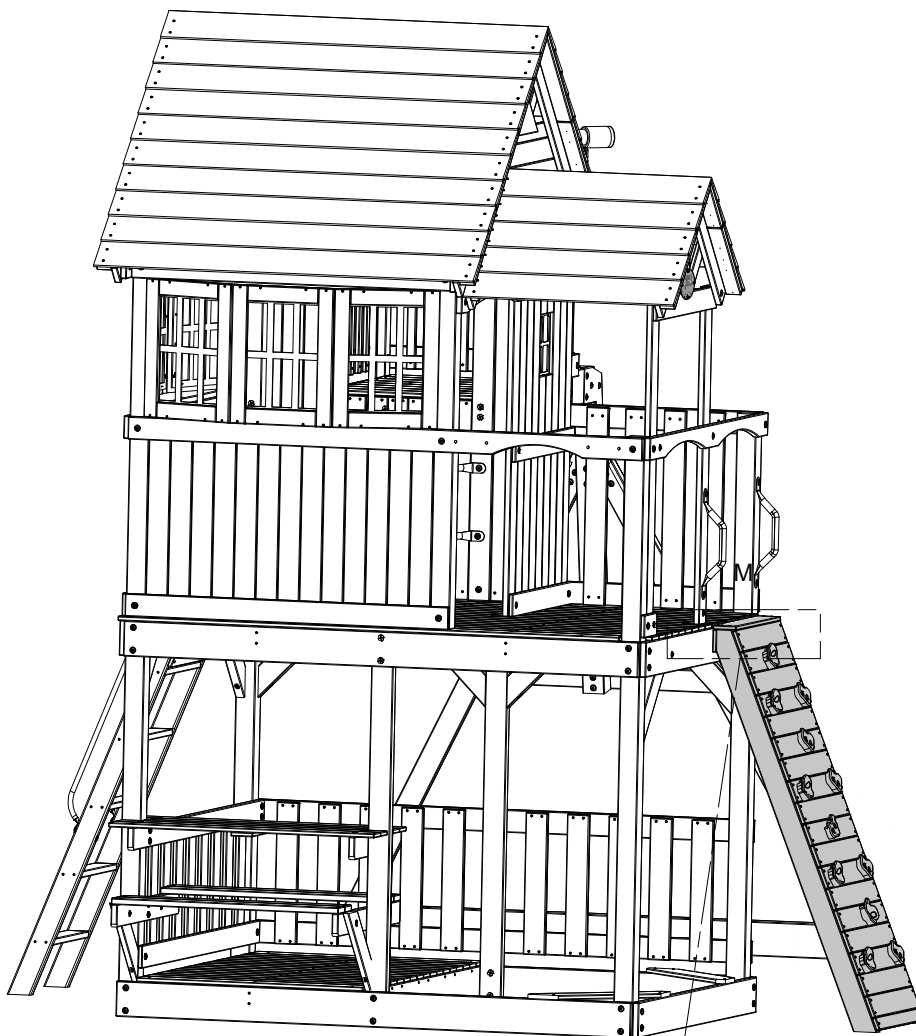

010 (x2)  
BOLT - 1 1/2"

030 (x2)  
WASHER - 8x19

ROCK WALL ASSEMBLY

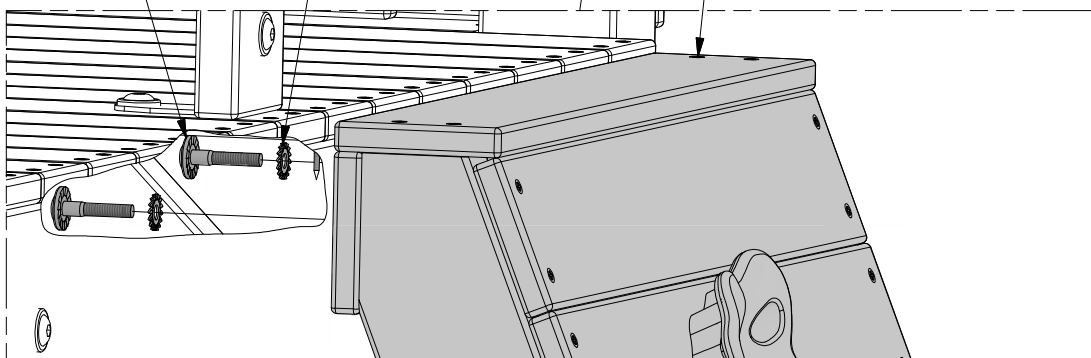

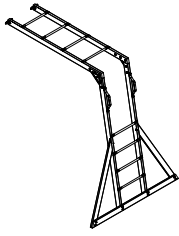
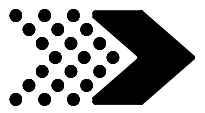

(1) MONKEY BAR ASSEMBLY

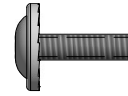

**H100008** | BOLT WH  
(4) | 5/16x1

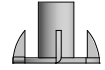

**H100074** | T-NUT  
(4) | 5/16



**TIP:**  
INSTALL T-NUTS INTO  
BOARDS BEFORE ASSEMBLY.

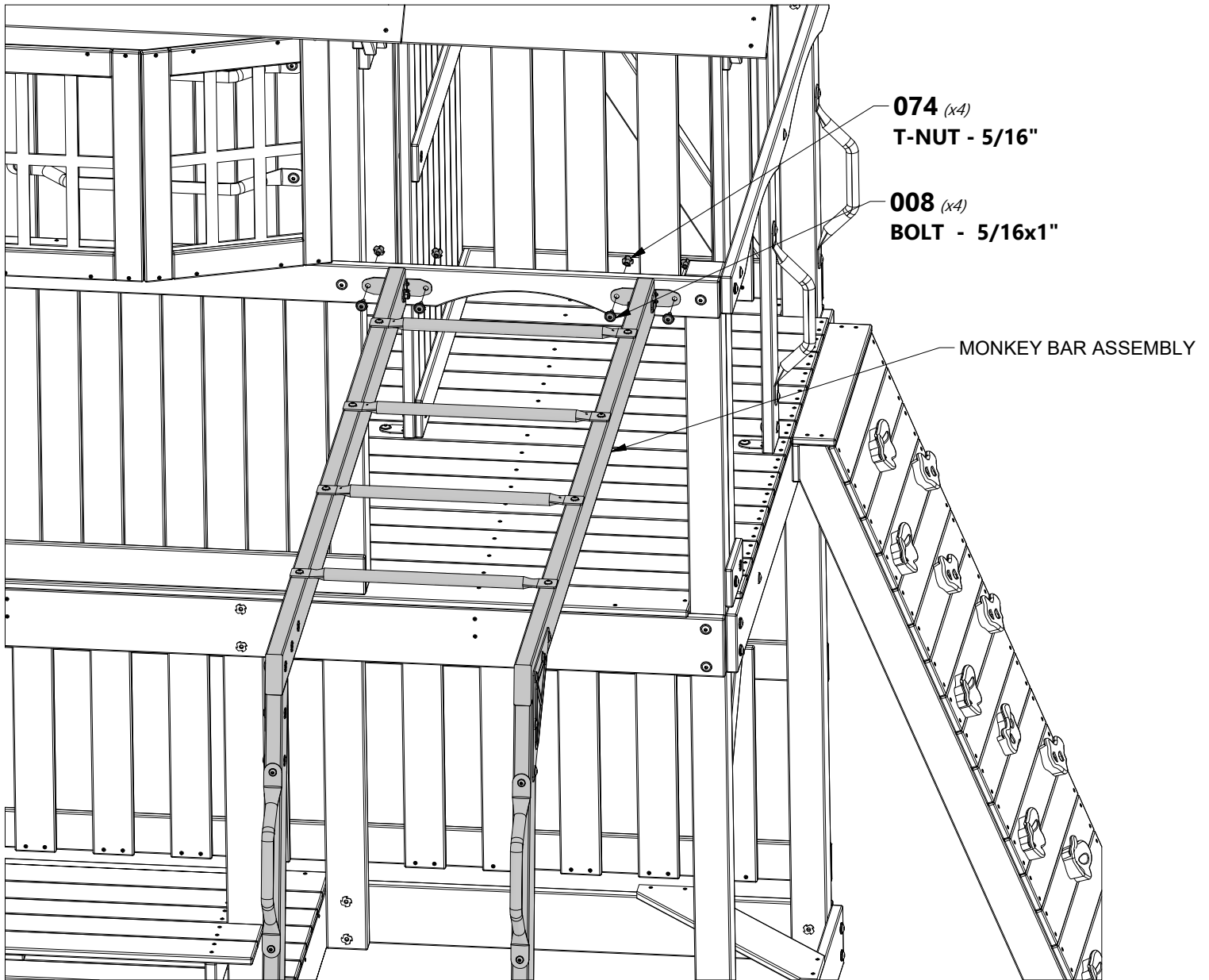



# FINAL ASSEMBLY

# STEP 3

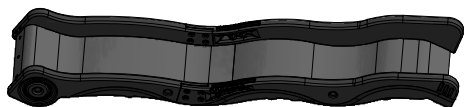

(1) SLIDE ASSEMBLY



H100115 | BOLT WH  
(3) | 5/16x1/2



H100074 | T-NUT  
(3) | 5/16



**TIP:**  
INSTALL T-NUTS INTO  
BOARDS BEFORE ASSEMBLY.

**NOTE:**  
CENTER SLIDE IN OPENING. USING DIMENSIONS BELOW AS  
A TEMPLATE, DRILL (3) 3/8" HOLES THROUGH DECK FOR HARDWARE.

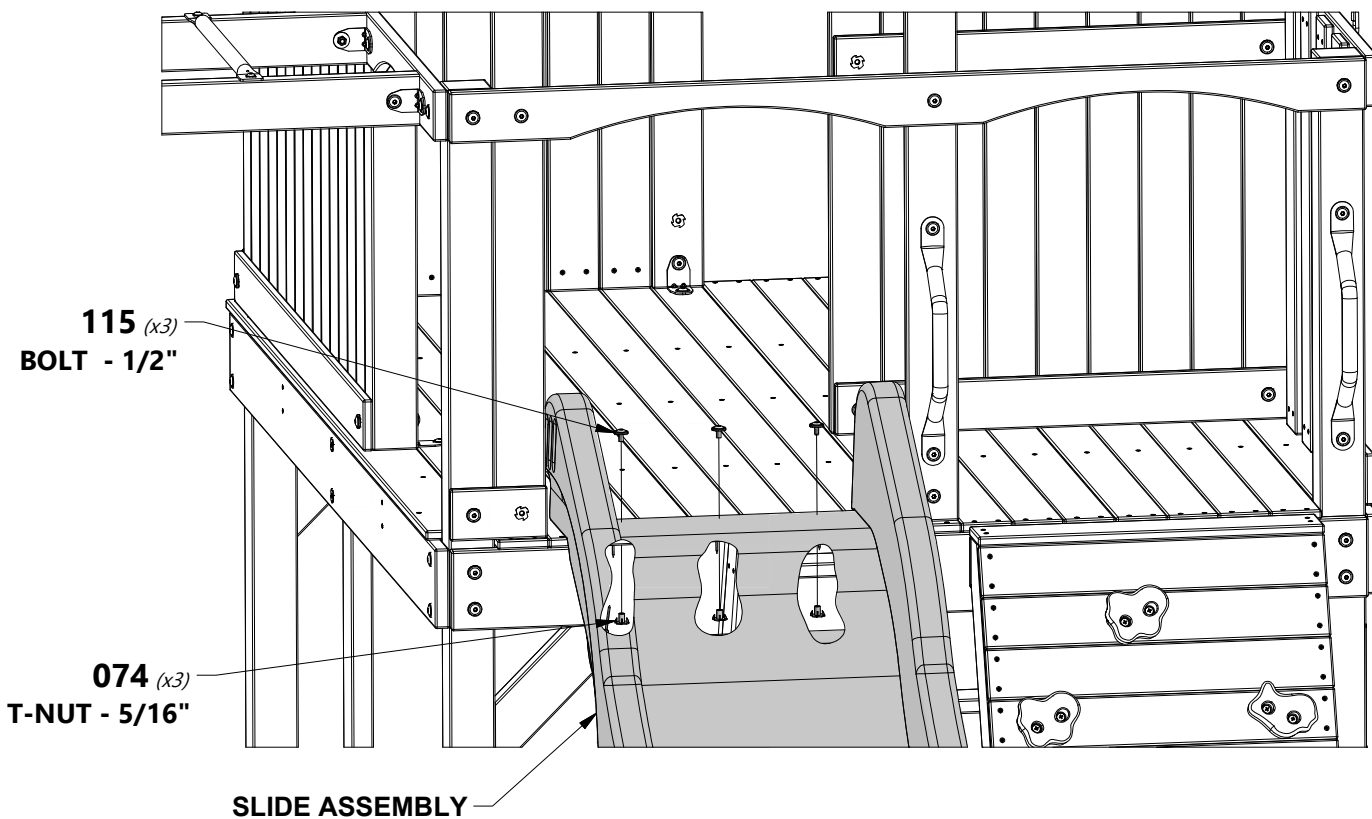
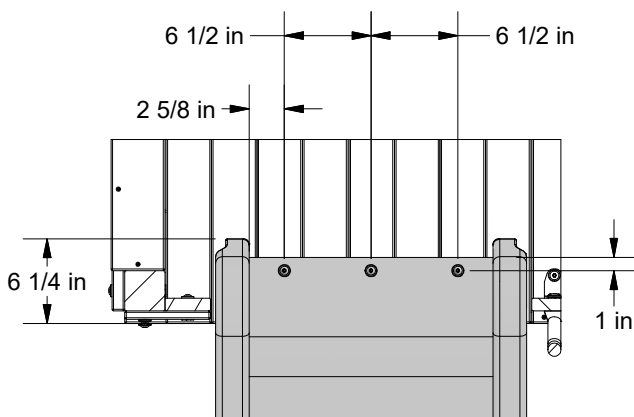



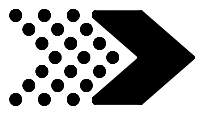

A100314 | "A" REVISION TAG  
(1)



H100128 | SCREW PWH  
(2) | 8x5/8

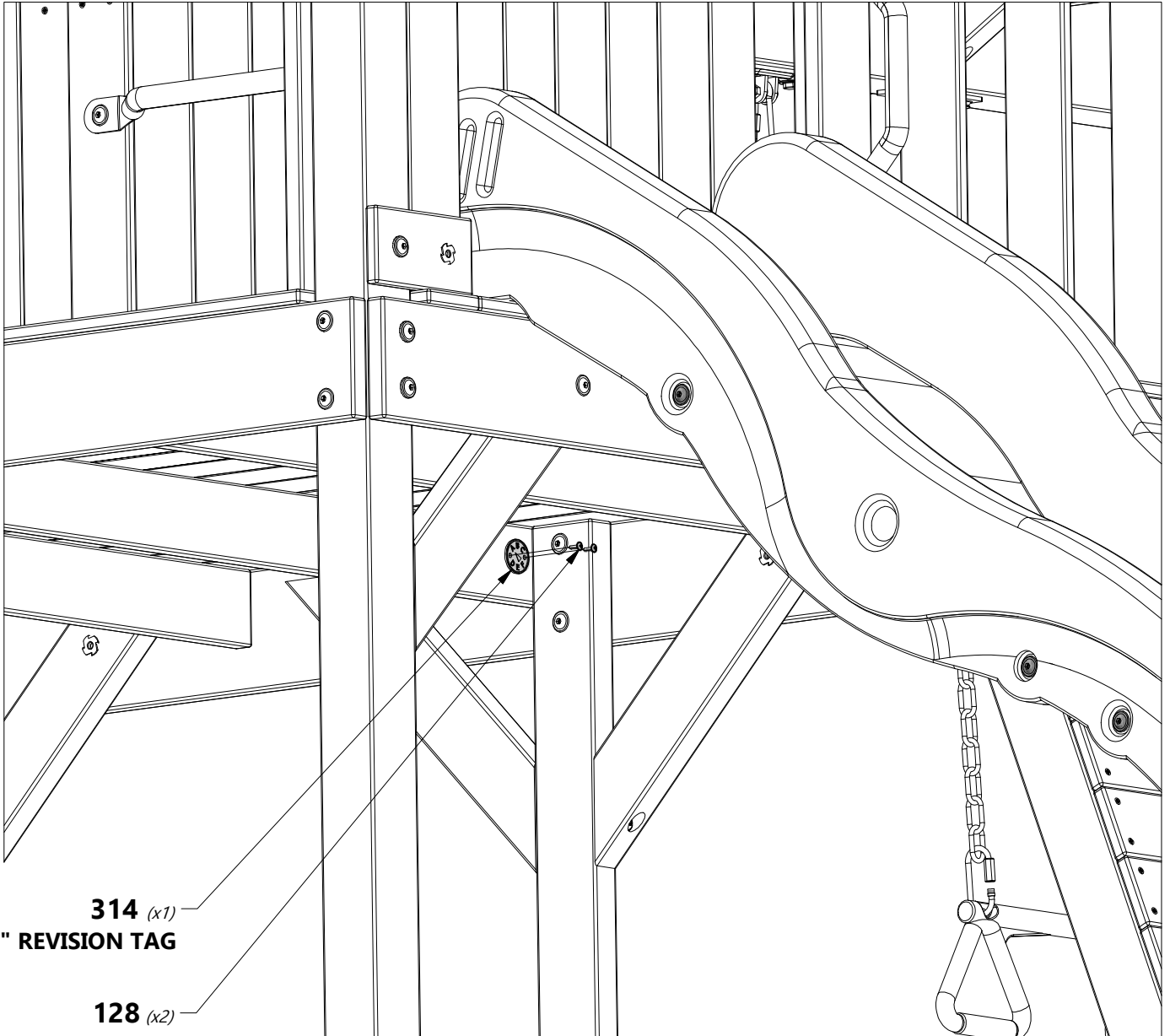

314 (x1)

"A" REVISION TAG

128 (x2)

SCREW - 5/8

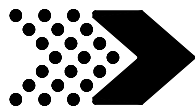

# FINAL ASSEMBLY

# STEP 5



**A100177** | CHAIN GREEN  
(2) | 31"



**A100047** | CHAIN GREEN  
(4) | 57"



**A100069** | QUICK LINK  
(6)



**A100027** | SWING SEAT GREEN 26"  
(2)



**A6P00034** | TRAPEZE YELLOW  
(1)

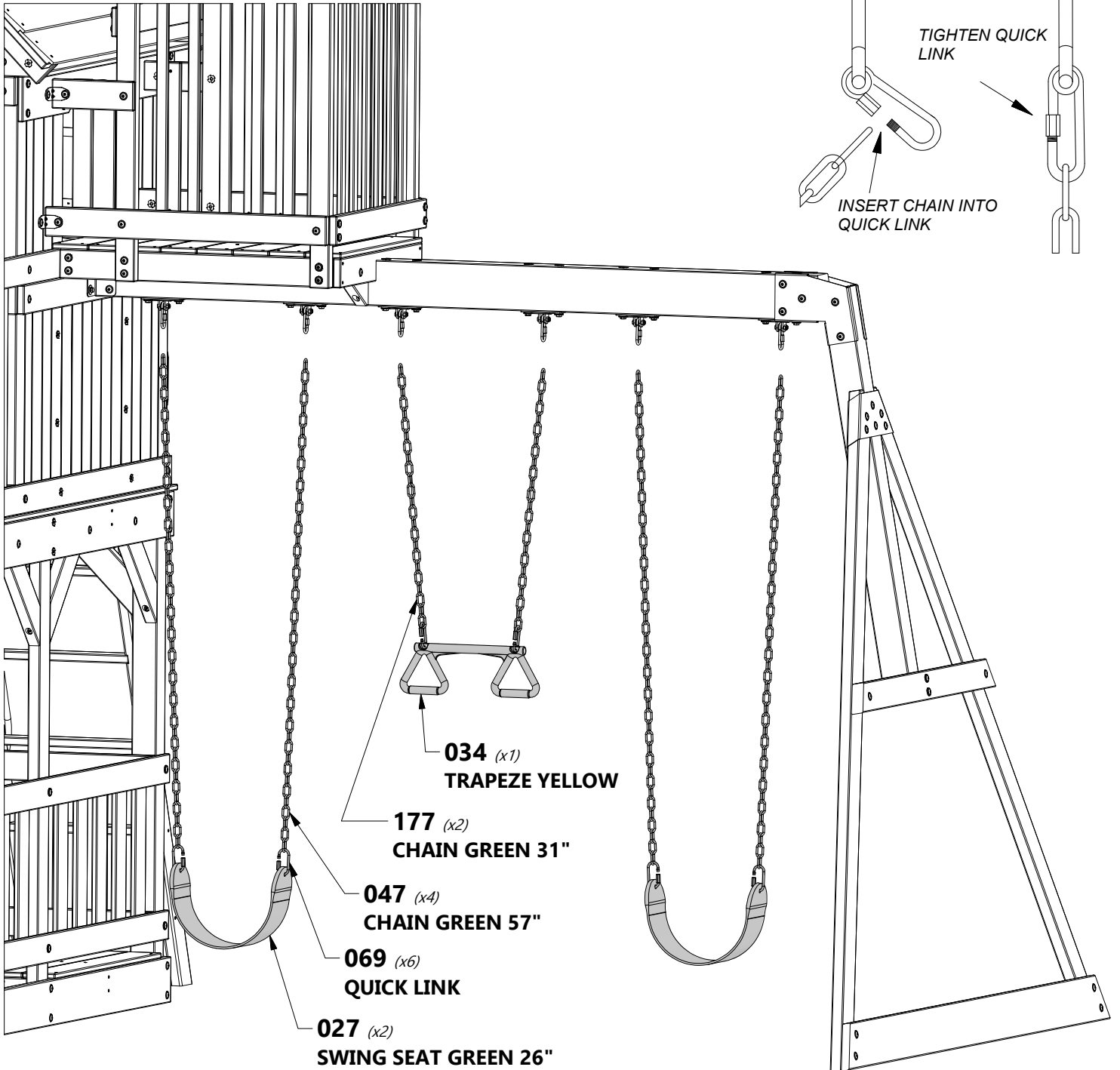

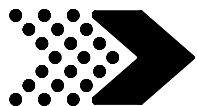

# FINAL ASSEMBLY

# STEP 6



A100178 | AUGER GROUND STAKE  
(8)



A4M00527 | GROUND STAKE REBAR  
(2)



H100145 | LAG SCREW WH  
(8) | 1/4x1 1/2



H100106 | WASHER FLAT  
(8) | 9x18



H100031 | WASHER LOCK  
(2) | EXT  
12x19

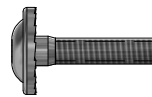

H100009 | BOLT WH  
(2) | 5/16x1 1/4



H100004 | NUT BARREL WH  
(2) | 5/16 x 5/8

**FINAL STEP**  
DOUBLE CHECK EVERY BOLT, SCREW AND NUT FOR TIGHTNESS. MAKE SURE EVERY BOARD IS SECURE AND MAKE SURE THE PLAY SET IS LEVEL.

**NOTE:**  
FAILURE TO ATTACH GROUND STAKES COULD CAUSE INJURY AND WILL VOID WARRANTY!

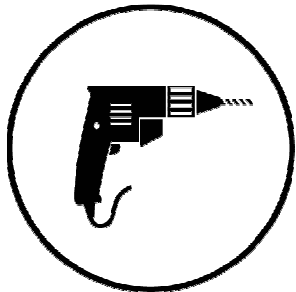

**DETAIL 'A'**  
TWIST STAKES INTO GROUND AGAINST GROUND BOARDS AND CORNER POSTS IN LOCATIONS SHOWN. USING STAKE AS A TEMPLATE, DRILL A 3/16" [5 mm] HOLE FOR LAGS.

**DETAIL 'B'**  
TWIST STAKES INTO GROUND AGAINST GROUND BOARDS AND CORNER POSTS IN LOCATIONS SHOWN. USING STAKE AS A TEMPLATE, DRILL A 3/16" [5 mm] HOLE FOR LAGS.

**DETAIL 'C' & 'D'**  
DRIVE STAKE INTO GROUND AT LOCATIONS SHOWN. USING STAKE AS A TEMPLATE, DRILL A 7/16" [10 mm] HOLE FOR HARDWARE.

